

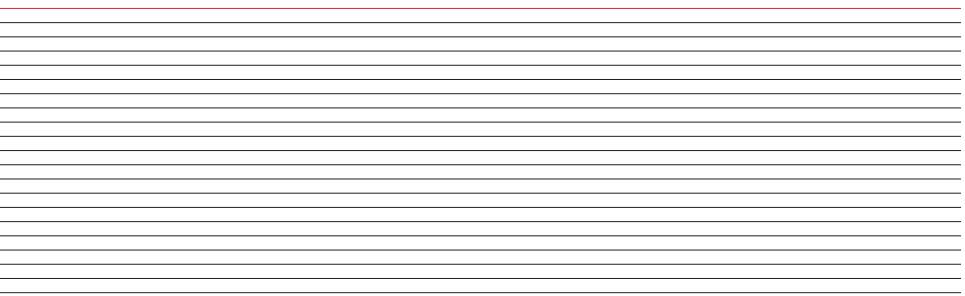

CATALOG | PRECISION GAGES



|
- 0 +



EXACTLY

MAHR PRECISION GAGES

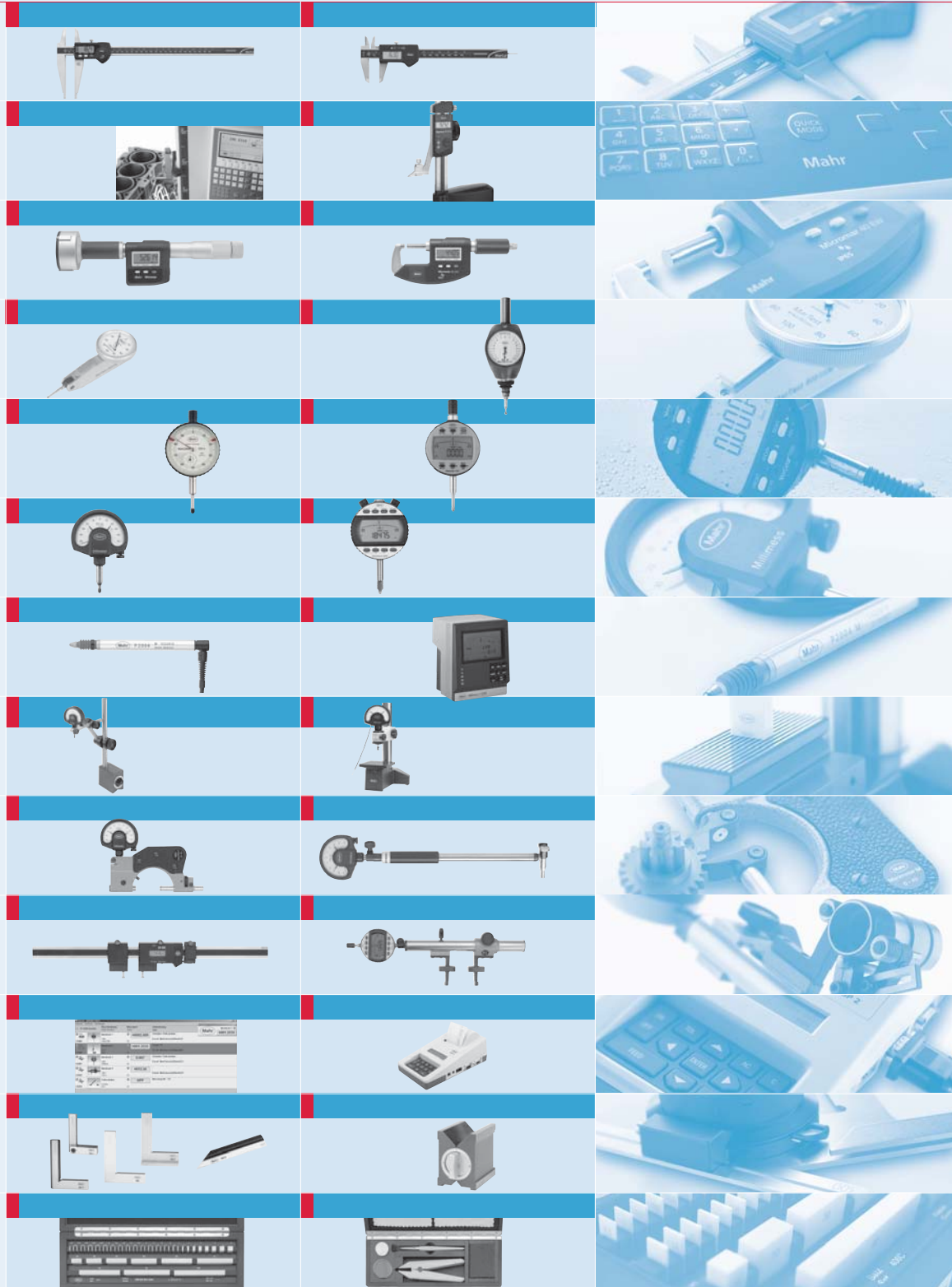

► | Contents

MarCal	Calipers	1- 2
Digimar	Height Measuring Instruments	2- 2
Micromar	Micrometers	3- 2
MarTest	Test Indicators / 3D Touch Probes	4- 2
MarCator	Digital / Dial Indicators	5- 2
Millimess	Digital / Dial Comparators	6- 2
Millimar	Electrical Length Measuring Instruments / Air Gaging	7- 2
MarStand	Indicator Stands / Comparator Stands	8- 2
MaraMeter	Indicating Measuring Instruments	9- 2
Multimar	Universal Measuring Instruments	10- 2
MarConnect	Interfaces / Data Processing	11- 2
MarTool	Measuring and Inspection Equipment	12- 2
MarGage	Standards, Gages and Gage Blocks	13- 2

FOR SIMPLE MEASUREMENT THE RULE OF
THUMB IS SUFFICIENT.
FOR THE REST THERE IS MARCAL.



The latest information on MARCAL products can be found on our website:
www.mahr.com, WebCode 203

▶ | High-quality calipers are amongst the most important measuring instruments in Dimensional Metrology because they are both versatile and easy to use, such as the MarCal series from Mahr. The ER digital caliper series is simple to operate, has a large, easy to read display and enables fast and uncomplicated data transmission thus meeting all requirements of modern metrology. The new generation of Mahr calipers is the MarCal 16 EWR a waterproof digital caliper, which enables measurement even in the most difficult workshop conditions. In addition all the Mahr calipers have a highly precise slide movement as well as both the slide and beam being made of hardened stainless steel thus completing the outstanding characteristics of Mahr calipers.

▶ | MarCal. Calipers

Overview

MarCal Calipers

1- 2

Standard Calipers

MarCal 16 EWR

Waterproof Caliper with a Digital Display

1- 4

MarCal 16 ER

With a Digital Display

1- 8

MarCal 16 DN / 16 FN / 16 GN / 16 N

With a Line Scale (Vernier)

1-10

MarCal 16 U

With a Circular Scale

1-11

Universal Calipers

MarCal 16 EWV

With a Digital Display

1-12

Workshop Calipers

MarCal 18 EWR / 18 ESA

With a Digital Display

1-14

MarCal 18 NA / 18 N / 18 DN

With a Line Scale (Vernier)

1-17

Depth Calipers

MarCal 30 EWR / 30 ER / 30 EWN

With a Digital Display

1-20

MarCal 30 N / 30 NH / 30 ND

With a Line Scale (Vernier)

1-24

Linear Machine Scales

MarCal 31 ES / 32 ES

With a Digital Display

1-25

MarCal. Calipers

OVERVIEW

MarCal - Design Features

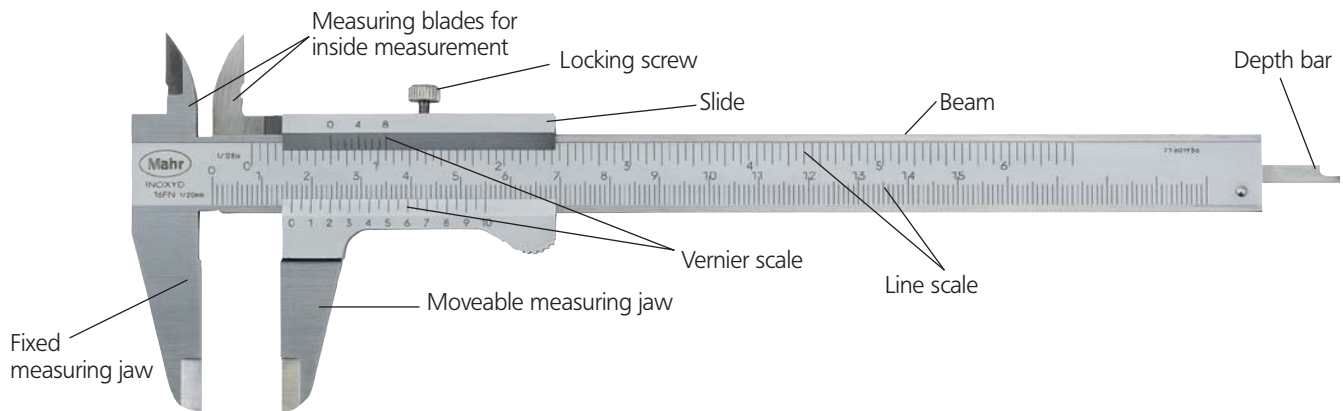

MarCal - Types on measurement

Calipers of the 16 series (e.g. 16 EWR, 16 U, 16 FN) can be used for 4 different measurements:

a) Outside measurement

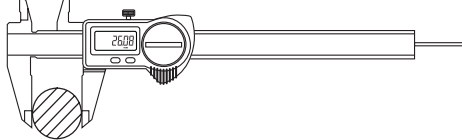

b) Inside measurement

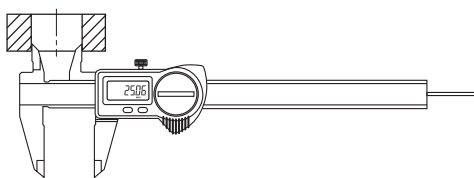

c) Depth measurement

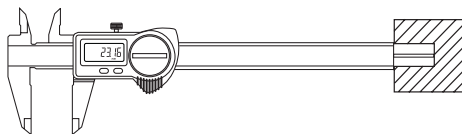

d) Step (Distance) measurement

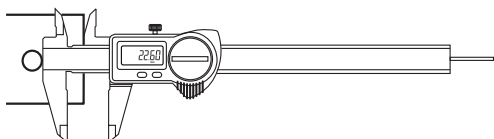

Error limits G according to DIN 862

Measuring length	Error limits G in μm		Resolution
	Scale interval and/or vernier interval		
/	0.1 and 0.05	0.02	0.01
50	50	20	20
100			
200			
300	60	30	30
400			
500			
600			
700	90	40	40
800			
900			
1000			
1200			
1400	140	50	—
1600			
1800			
2000			
2200			
2400			

MarCal - The innovative Reference-System

Just set once to zero

All Mahr digital calipers with this logo **REFERENCE** are equipped with the innovative Reference-System. The zero position just has to be set once: after setting the zero position, the zero remains stored for all further measurements. Therefore, once the caliper is switched ON or the slide is moved the caliper is immediately ready for measurement. The need to reset to zero with a conventional caliper once the caliper is switched on has now become obsolete.

Conventional

- ① Switch ON ② Close the measuring jaws ③ Set to zero ④ Results of measurement

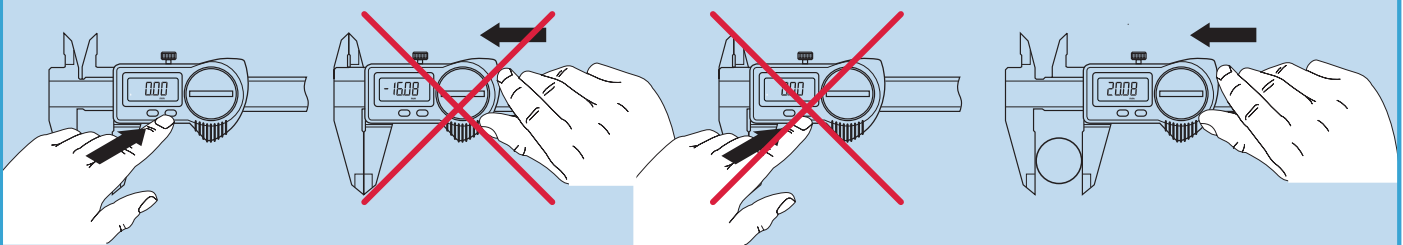

REFERENCE - System

- ① Switch ON ② Results of measurement

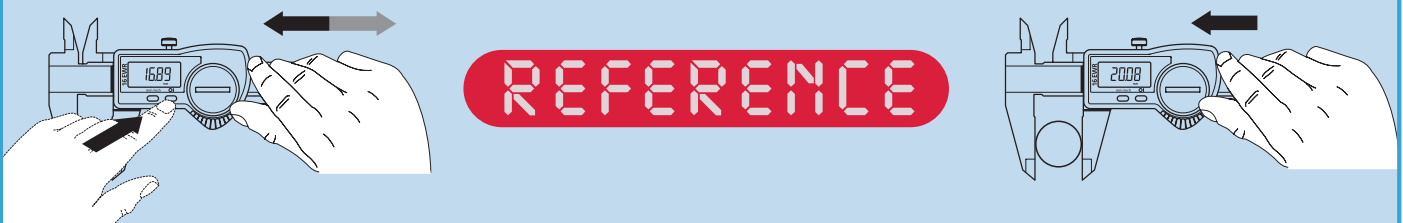

Press the ON key or move the slide

IP-Protection classes

First digit is the degree of protection according to IEC 60529		Second digit is the degree of protection according to IEC 60529 (approximate)	
Protection against particles, contaminants and dust		Protection against wet conditions (fluids)	
0	Not protected	0	Not protected
1	Particles > 50.0 mm	1	Falling water drops - vertical
2	Particles > 12.5 mm	2	Falling water drops - tilted < 15°
3	Particles > 2.5 mm	3	Spray water < 60°
4	Particles > 1.0 mm	4	Water splashing from all directions
5	Dust protected	5	Water jets from all directions
6	Dust tight	6	Powerful water jets
		7	Temporary immersion in water
		8	Continuous immersion in water



Example:
IP67 means that the product is "Dust tight" and is protected against "Temporary immersion in water".

MarCal. The new Generation with the Reference-System

WATERPROOF CALIPERS

► | The water-proof digital caliper **MarCal** 16 EWR, with protection class IP67 and the Reference Lock-Function, ensures both accurate and reliable results even in the most toughest workshop conditions. | ◀

The high-contrast display with 8.5 mm high digits enables accurate, fatigue free reading of the measurement results.



Universal SPC-interface (optional). You have a choice of **MarConnect** data outputs, select either **USB**, **Digimatic** or **Mahr Opto RS232**



USB



RS232C



Digimatic

 The **Reference-Lock-Function** prevents operating error caused by accidental usage of the operating buttons.



The new Reference system is extremely energy efficient as when the caliper is in standby mode; almost no power is required, thus **extending the life of the battery to up to 50%**.

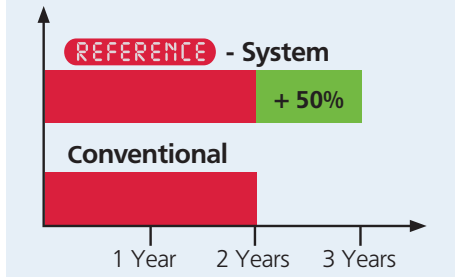

Lapped measuring faces for accurate measurement.



MarCal calipers have **lapped guide way surfaces**, these guarantee an even and sensitive run of the slide.

Surface of the guide way



Mahr

Lapped guide way

Code Initials	IP	International Protection
First digit	6	Dust-tight
Second digit	7	Protected against temporary immersion in water

 Protection class **IP67** in accordance to IEC 60529, the water proof measuring system **FPS** (Fluid Protected measuring System) with a sealed housing.

Digital Caliper MarCal 16 EWR

DIN
862

REFERENCE

Features



Functions:

- ON/OFF
- RESET (Set display to zero)
- mm/inch
- Reference-Lock/Unlock
- Auto-ON/OFF
- Immediate measurement due to the Reference system

- Excellent resistance against dust, coolants and lubricants, protection class IP67
- Dirt wipers are integrated in the slide
- Life of the battery up to 3 years
- Max measuring speed 2.5 m/s (100"/s)
- High contrast Liquid Crystal Display with 8.5 mm high digits
- Lapped guide way
- Slide and beam made of hardened stainless steel
- Measuring blades for inside measurement
- Step measuring function

- Locking screw
- Supplied with: Case, battery, operating instructions

Technical Data

Measuring range mm (inch)	Resolution mm/inch	Error limit G mm/inch	Depth rod		Friction wheel	Order no.
						
150 (6")	0.01/ .0005"	0.03/ .001"	●	●		4103060
150 (6")	0.01/ .0005"	0.03/ .001"	●	●	●	4103062
150 (6")	0.01/ .0005"	0.03/ .001"	●	●	●	4103061
150 (6")	0.01/ .0005"	0.03/ .001"	●	●	●	4103063

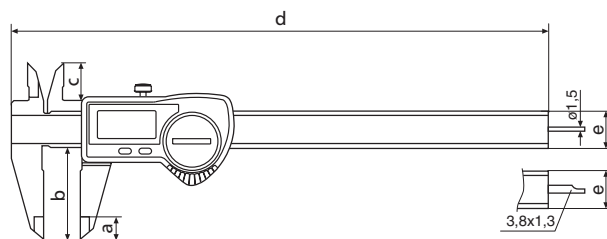

Dimensions

mm	a	b	c	d	e
150	10	40	16	235	16 x 3
200	10	50	19	285	16 x 3.5
300	14	64	19	388	16 x 4

Accessories

	Order no.
Depth Measuring Bridge	16 Em
Battery 3V, Type CR 2032	4102020 4102520

16 Em

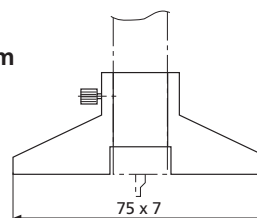

Digital Caliper MarCal 16 EWR with data output

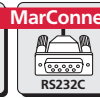
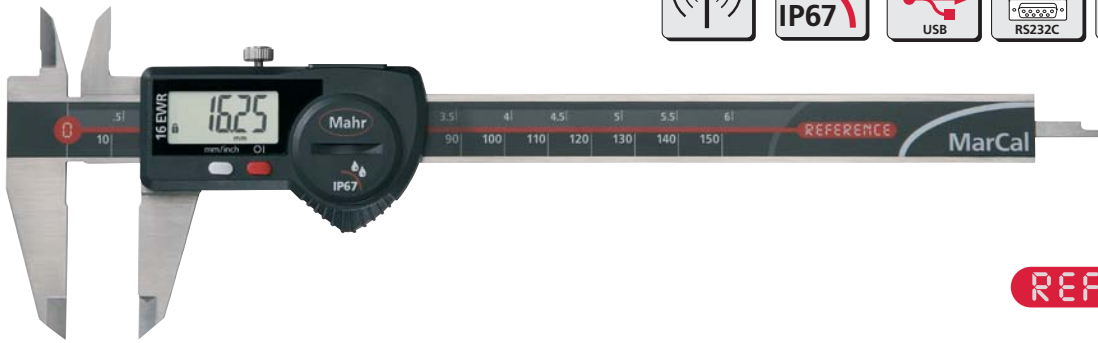

REFERENCE

Features

Functions:

- ON/OFF
- RESET (Set display to zero)
- mm/inch
- Reference-Lock/Unlock
- DATA (Data transmission via connection cable)
- Auto-ON/OFF
- Immediate measurement due to the Reference system

- Excellent resistance against dust, coolants and lubricants, protection class IP67
- MarConnect data output, choose alternatively: USB, OPTO RS232C or Digimatic
- Dirt wipers are integrated in the slide

- Life of the battery up to 3 years
- Max measuring speed 2.5 m/s (100"/s)
- High contrast LCD with 8.5 mm high digits
- Lapped guide way
- Slide and beam made of hardened stainless steel

- Measuring blades for inside measurement
- Step measuring function
- Locking screw
- Supplied with: Case, battery, operating instructions

Technical Data

Measuring range		Resolution	Error limit G		Depth rod		Friction wheel	Order no.
mm	(inch)	mm/inch	mm/inch	DIN 862				
150	(6")	0.01/ .0005"	0.03/ .001"	●	●			4103064
150	(6")	0.01/ .0005"	0.03/ .001"	●		●		4103066
200	(8")	0.01/ .0005"	0.03/ .001"	●		●		4103068
300	(12")	0.01/ .0005"	0.04/ .0015"	●				4103070
150	(6")	0.01/ .0005"	0.03/ .001"	●	●		●	4103065
150	(6")	0.01/ .0005"	0.03/ .001"	●		●	●	4103067
200	(8")	0.01/ .0005"	0.03/ .001"	●		●	●	4103069
300	(12")	0.01/ .0005"	0.04/ .0015"	●			●	4103071

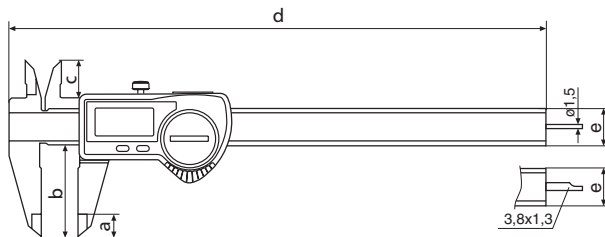

Dimensions

mm	a	b	c	d	e
150	10	40	16	235	16 x 3
200	10	50	19	285	16 x 3.5
300	14	64	19	388	16 x 4

Accessories

	Order no.
Depth Measuring Bridge	16 Em 4102020
Battery 3V, Type CR 2032	4102520
Data Connection Cable USB (2 m)	16 EXu 4102357
Data Connection Cable Opto RS232C (2 m), with SUB-D jack 9-pin	16 EXr 4102410
Data Connection Cable Digimatic (2 m), Flat plug 10-pin	16 EXd 4102411

Accessories for Data Processing see Chapter 11

Digital Caliper MarCal 16 EWR with ceramic measuring faces



Features

Functions:

- ON/OFF
- RESET (Set display to zero)
- mm/inch
- Reference-Lock/Unlock
- DATA (Data transmission via connection cable)
- Auto-ON/OFF
- Immediate measurement due to the Reference system

- Excellent resistance against dust, coolants and lubricants, protection class IP67
- MarConnect data output, choose alternatively: USB, OPTO RS232C or Digimatic
- Dirt wipers are integrated in the slide
- Life of the battery up to 3 years

- Max measuring speed 2.5 m/s (100"/s)
- High contrast LCD with 8.5 mm high digits
- Lapped guide way
- Slide and beam made of hardened stainless steel
- Ceramic measuring faces for external measurement

- Measuring blades for inside measurement
- Step measuring function
- Locking screw
- Supplied with: Case, battery, operating instructions

Technical Data

Measuring range	Resolution	Error limit G	Depth rod	Order no.
mm (inch)	mm/inch	mm/inch		
150 (6")	0.01/ .0005"	0.03/ .001"	●	4103072

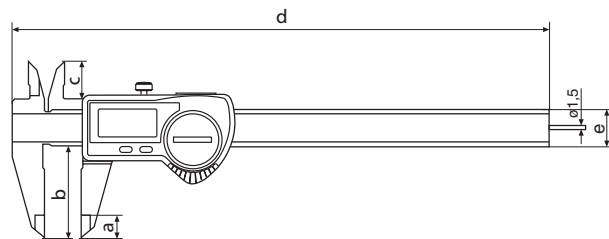

Dimensions

mm	a	b	c	d	e
150	10	40	16	235	16 x 3

Accessories

	Order no.
Depth Measuring Bridge	16 Em 4102020
Battery 3V, Type CR 2032	4102520
Data Connection Cable USB (2 m)	16 EXu 4102357
Data Connection Cable Opto RS232C (2 m), with SUB-D jack 9-pin	16 EXr 4102410
Data Connection Cable Digimatic (2 m), Flat plug 10-pin	16 EXd 4102411

Accessories for Data Processing see Chapter 11

Digital Caliper MarCal 16 ER



REFERENCE

Features

Functions:

- ON/OFF
- RESET (Set display to zero)
- mm/inch
- Reference-Lock/Unlock
- Auto-ON/OFF
- Immediate measurement due to the Reference system

- Dirt wipers are integrated in the slide
- Life of the battery up to 3 years
- Max measuring speed 2.5 m/s (100"/s)

- High contrast Liquid Crystal Display with 8.5 mm high digits
- Lapped guide way
- Slide and beam made of hardened stainless steel

- Measuring blades for inside measurement
- Step measuring function
- Locking screw
- Supplied with: Case, battery, operating instructions

Technical Data

Measuring range	Resolution	Error limit G	Depth rod		Order no.
			mm	(inch)	
150 (6")	0.01 / .0005"	0.03 / .001"	•	•	4103000
150 (6")	0.01 / .0005"	0.03 / .001"	•	•	4103001

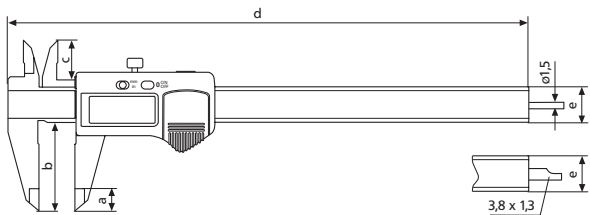

Dimensions

mm	a	b	c	d	e
150	10	40	16	233	16 x 3

Accessories

	Order no.
Depth Measuring Bridge	16 Em
Battery 3V, Type CR 2032	4102020 4102520

16 Em

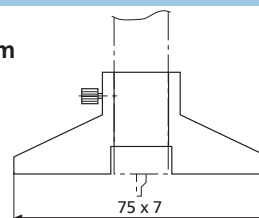

Digital Caliper MarCal 16 ER with data output



Features

- Functions:**
- ON/OFF
 - RESET (Set display to zero)
 - mm/inch
 - Reference-Lock/Unlock
 - Auto-ON/OFF
- Immediate measurement due to the Reference system
 - MarConnect data output, choose alternatively: USB, OPTO RS232C or Digimatic
 - Dirt wipers are integrated in the slide
 - Life of the battery up to 3 years
 - Max measuring speed 2.5 m/s (100"/s)
 - High contrast Liquid Crystal Display with 8.5 mm high digits
 - Lapped guide way
 - Slide and beam made of hardened stainless steel
 - Measuring blades for inside measurement
 - Step measuring function
 - Locking screw
 - Supplied with: Case, battery, operating instructions

Technical Data

Measuring range		Resolution	Error limit G	Depth rod	Data output	Order no.
mm	(inch)	mm / inch	mm/inch			
150	(6")	0.01 / .0005"	0.03/ .001"	•	•	4103002
150	(6")	0.01 / .0005"	0.03/ .001"	•	•	4103003
200	(8")	0.01 / .0005"	0.03/ .001"	•	•	4103004
300	(12")	0.01 / .0005"	0.04/ .0015"	•	•	4103005

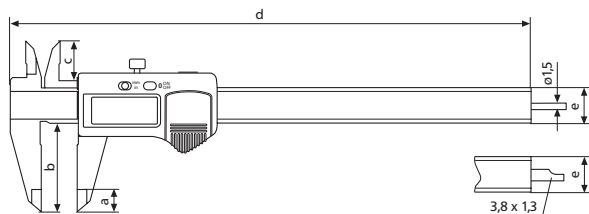

Dimensions

mm	a	b	c	d	e
150	10	40	16	235	16 x 3
200	10	40	16	285	16 x 3
300	14	64	18	388	16 x 4

Accessories

	Order no.
Depth Measuring Bridge	16 Em 4102020
Battery 3V, Type CR 2032	4102520
Data Connection Cable USB (2 m)	16 EXu 4102357
Data Connection Cable Opto RS232C (2 m), with SUB-D jack 9-pin	16 EXr 4102410
Data Connection Cable Digimatic (2 m), Flat plug 10-pin	16 EXd 4102411

Accessories for Data Processing see Chapter 11

16 Em

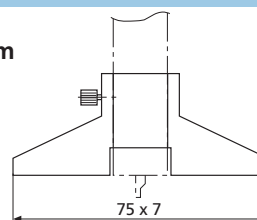

Vernier Calipers MarCal 16 N, 16 FN, 16 GN, 16 DN with scale reading

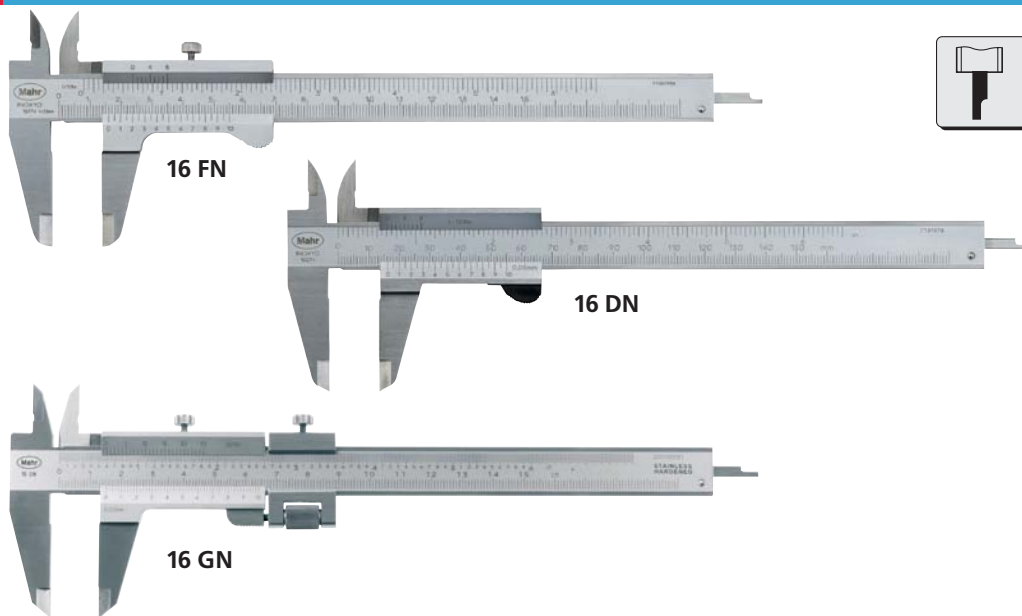

Features

- Vernier and main scale have a satin chrome finish for glare free reading
 - Slide and beam made of hardened stainless steel
 - Raised guide ways for the protection of the scale
 - Measuring blades for inside measurement
 - Step measuring function
 - Depth bar
 - Locking screw or thumb clamp
- Supplied with:
Plastic case and thread table

Technical Data

	Measuring range		Readings		Error limit G	DIN 862	Order no. without fine adjustment	Order no. with fine adjustment	Remarks
	mm	(inch)	upper inch	lower mm					
16 FN	150			0.05	0.05	●	4100420		Locking screw above Locking screw above Thumb clamp Locking screw below
16 FN	150	(6")	1/128"	0.05	0.05/.0020"	●	4100400		
16 DN	150	(6")	1/128"	0.05	0.05/.0020"	●	4100600		
16 N	150	(6")	1/128"	0.05	0.05/.0020"	●	4100500		Locking screw above Locking screw above Thumb clamp Locking screw below
16 GN	150			0.02	0.04	●	4100650	4100660*	
16 GN	150	(6")	.001"	0.02	0.04/.0016"	●	4100670	4100680*	
16 FN	200			0.05	0.05	●	4100421		Locking screw above
16 FN	200	(8")	1/128"	0.05	0.05/.0020"	●	4100401		
16 GN	200			0.02	0.05	●	4100651	4100661*	
16 GN	200	(8")	.001"	0.02	0.05	●	4100671	4100681*	
16 FN	300			0.05	0.05	●	4100422		Locking screw above
16 FN	300	(12")	1/128"	0.05	0.05/.0020"	●	4100402		
16 GN	300			0.02	0.05	●	4100652	4100662*	
16 GN	300	(12")	.001"	0.02	0.05	●	4100672	4100682*	

* Calipers with fine adjustment the measuring range is shortened by 20 mm / 1"

Dimensions

mm	a	b	c	d	e	f
150	10	40	16	228	16 x 3	3.8
200	14	50	19	290	17 x 3.5	3.8
300	16	64	23	404	20 x 4	4.8

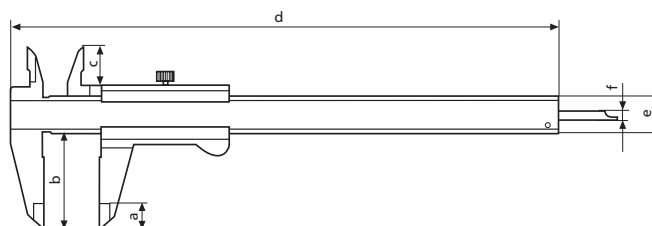

Accessories

	Order no.
Depth Measuring Bridge	16 Em 4102020
Leather case for meas. range 150 mm	4100302

16 Em

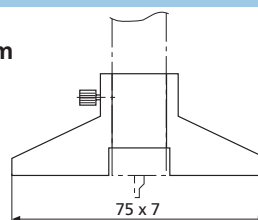

Vernier Caliper MarCal 16 U with circular scale

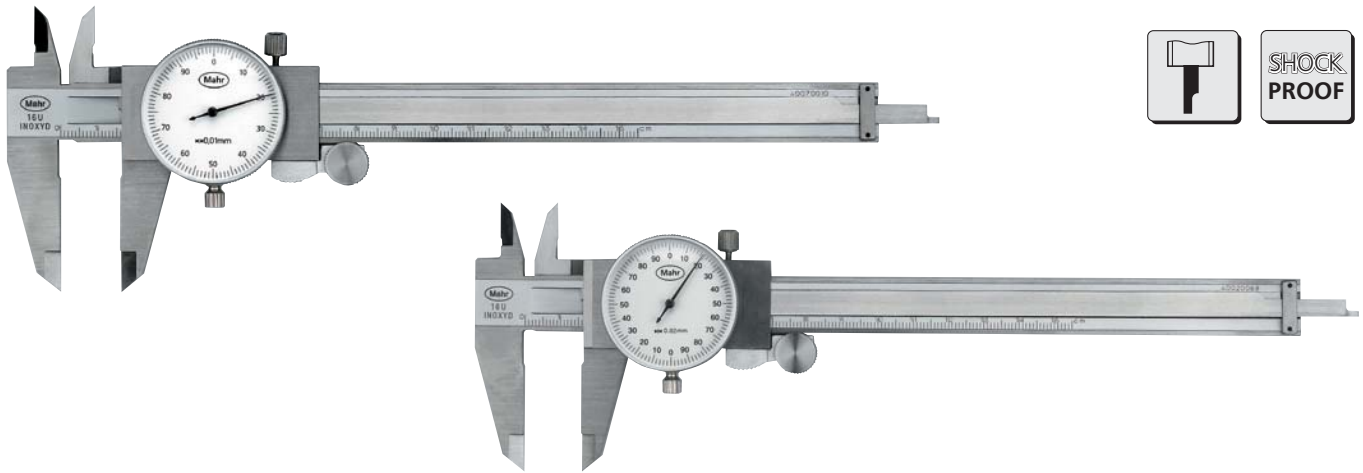

Features

- Large, high contrast dial face
- Satin chrome finished line scale
- Shockproof movement
- Zero setting through rotating the dial face and locking screw
- Covered rack
- Slide and beam made of hardened stainless steel
- Measuring blades for inside measurement
- Step measuring function
- Locking screw
- Depth bar
- Supplied with: Plastic case
- Inch model is supplied with a black dial face

Technical Data

Measuring range	Readings	Diameter of circular scale	1 Pointer-revolution	Dial face color	Error limit G	DIN 862	Order no.
150 mm	0.01 mm	34 mm	1 mm	white	0.03 mm	●	4107005
150 mm	0.02 mm	34 mm	2 mm	white	0.03 mm	●	4107107
6"	.001"	1.3"	.100"	black	.0012"		4107900

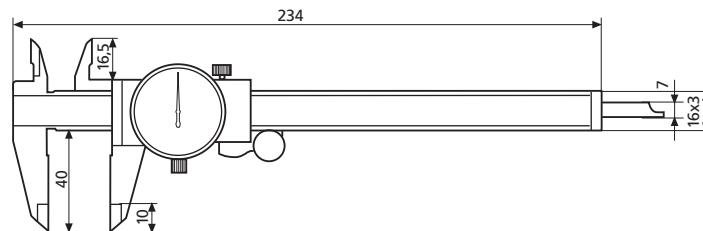

Accessories

	Order no.	16 Em
Depth Measuring Bridge	4102020	
Leather case for meas. range 150 mm	4100302	

Universal Digital Caliper MarCal 16 EWW in set

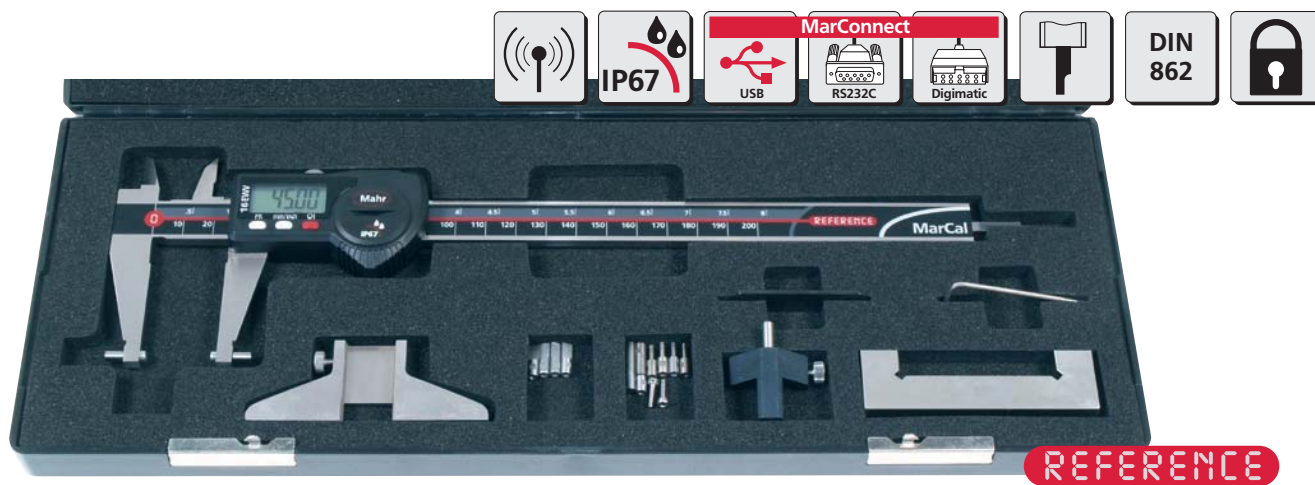

Applications

- The 16 EWW can also be used as a standard caliper (4 types of measurement).

When used in conjunction with the standard accessories; it is possible to measure recesses, grooves, etc.

In conjunction with the additional accessories; threads, bores, serrations, etc. can be measured.

Features

Functions:

- ON/OFF
- RESET (Set display to zero)
- mm/inch
- Reference-Lock/Unlock
- DATA (Data transmission via connection cable)
- Auto-ON/OFF
- Immediate measurement due to the Reference system
- Excellent resistance against dust, coolants and lubricants, protection class IP67

- MarConnect data output, choose alternatively: USB, OPTO RS232C or Digimatic
- Dirt wipers are integrated in the slide
- Life of the battery up to 3 years
- Max measuring speed 2.5 m/s (100"/s)
- High contrast LCD with 8.5 mm high digits
- Lapped guide way

- Slide and beam made of hardened stainless steel
- Measuring blades for inside measurement
- Step measuring function
- Locking screw
- Supplied with: Case, battery, operating instructions

Technical Data

Measuring range*		Resolution	Error limit G	Order no.
mm	(inch)	mm / inch	mm/inch	
200	(8")	0.01 / .0005"	0.03/ .001"	4118807**
200	(8")	0.01 / .0005"	0.03/ .001"	4118808***

* in conjunction with accessories the measuring range may change

** includes standard accessories

*** excludes standard accessories

Accessories

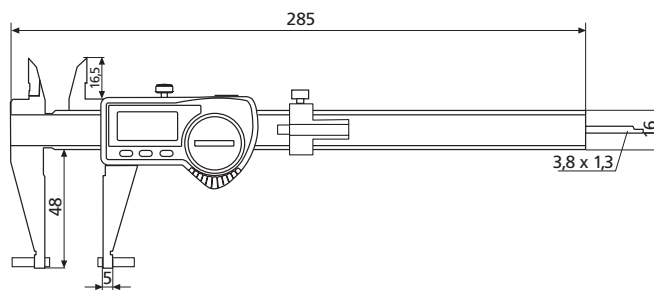

	Order no.
Battery 3V, Type CR 2032	4102520
Data Connection Cable USB (2 m)	16 EXu 4102357
Data Connection Cable Opto RS232C (2 m), with SUB-D jack 9-pin	16 EXr 4102410
Data Connection Cable Digimatic (2 m), Flat plug 10-pin	16 EXd 4102411

Accessories for Data Processing see Chapter 11

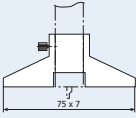
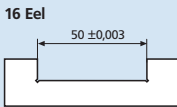
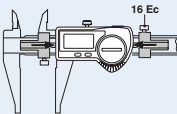
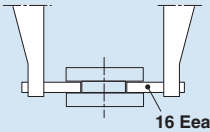
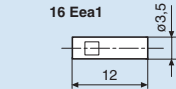
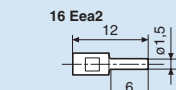
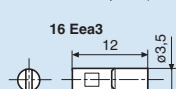
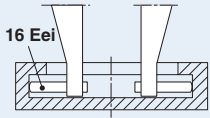
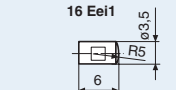
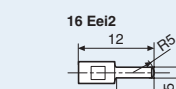

Universal Digital Caliper MarCal 16 EWW in set

Standard Accessories are included in the set

Catalog no.	Description	Order no.	Required quantity	Remarks		
16 Em	Depth Measuring Bridge	4102020	1			
16 Eel	Setting Gage for inside measurement	4118817	1			
16 Ec	Measuring Force Device	4118818	1			
16 Eea 1	Anvils for outside measurements	4118810	2			up to dia. 175 mm
16 Eea 2	Anvils for outside measurements	4118811	2			up to dia. 175 mm
16 Eea 3	Anvils for outside measurements	4118812	2			up to dia. 175 mm
16 Eei 1	Anvils for inside measurement	4118813	2			from dia. 27 mm
16 Eei 2	Anvils for inside measurement	4118814	2			from dia. 39 mm
16 Eei 3	Anvils for inside measurement	4118815	2			from dia. 39 mm
	Screws M2 x 8	4879602	2			

Additional Accessories

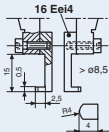
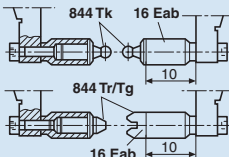
Catalog no.	Description	Order no.	Required quantity	Remarks	
16 Eei 4	Anvils for inside measurement	4118816	2		from dia. 8.5 mm
16 Eab	Mounting Attachment for 844Tg/Tr and 844 Tk	4118819	2		see Page 10-10
844 Tk	Ball Anvils		2		
844 Tg/Tr	Thread Anvils		1 + 1		see Page 10-12/10-14

Digital Caliper MarCal 18 EWR

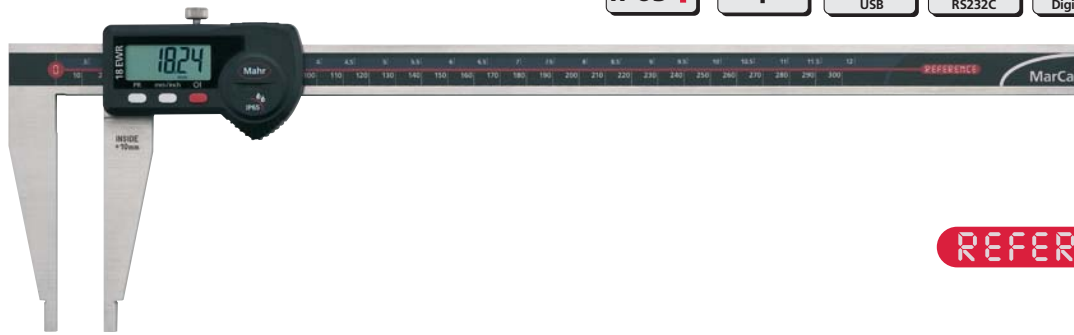

REFERENCE

Features

Functions:

- ON/OFF
- RESET (Set display to zero) mm/inch
- Reference-Lock/Unlock
- DATA (Data transmission via connection cable)
- Auto-ON/OFF

- Immediate measurement due to the Reference system
- Excellent resistance against dust, coolants and lubricants, protection class IP65
- MarConnect data output, choose alternatively: USB, OPTO RS232C or Digimatic

- Dirt wipers are integrated in the slide
- Life of the battery up to 3 years
- Max measuring speed 2.5 m/s (100"/s)
- High contrast LCD with 10 mm (only 300 mm) and 12.5 mm high digits

- Slide and beam made of hardened stainless steel
- Rounded measuring blades for inside measurement
- Locking screw
- Supplied with: Case, battery, operating instructions

Technical Data

Measuring range mm (inch)	Resolution mm / inch	Error limit G mm/inch	Weight kg	Order no.
300 (12")	0.01 / .0005"	0.03/ .001"	0.44	4112705
500 (20")	0.01 / .0005"	0.04/ .0015"	1.00	4112713
750 (30")	0.01 / .0005"	0.05/ .0020"	1.28	4112715
1000 (40")	0.01 / .0005"	0.06/ .0024"	2.10	4112717

Dimensions

mm	a	b	c	d	e
300	410	90	10	10	20 x 4.5
500	650	150	20	20	25 x 5.5
750	905	150	20	20	25 x 5.5
1000	1165	150	20	20	30 x 6.5

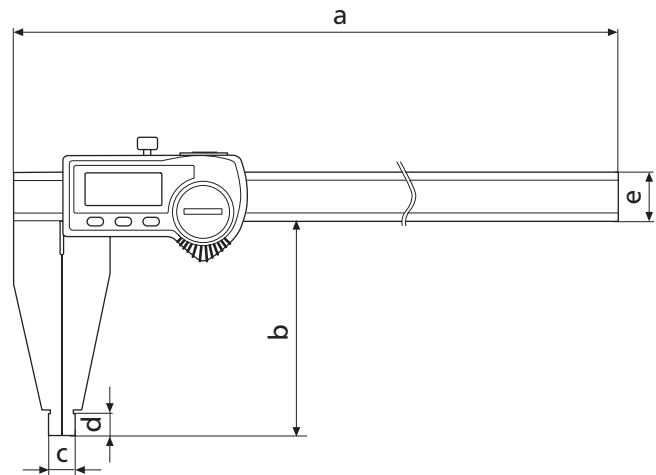

Accessories

	Order no.
Battery 3V, Type CR 2032	4102520
Data Connection Cable USB (2 m)	16 EXu 4102357
Data Connection Cable Opto RS232C (2 m), with SUB-D jack 9-pin	16 EXr 4102410
Data Connection Cable Digimatic (2 m), Flat plug 10-pin	16 EXd 4102411

Accessories for Data Processing see Chapter 11

Digital Caliper MarCal 18 EWR with measuring blades for outside measurement

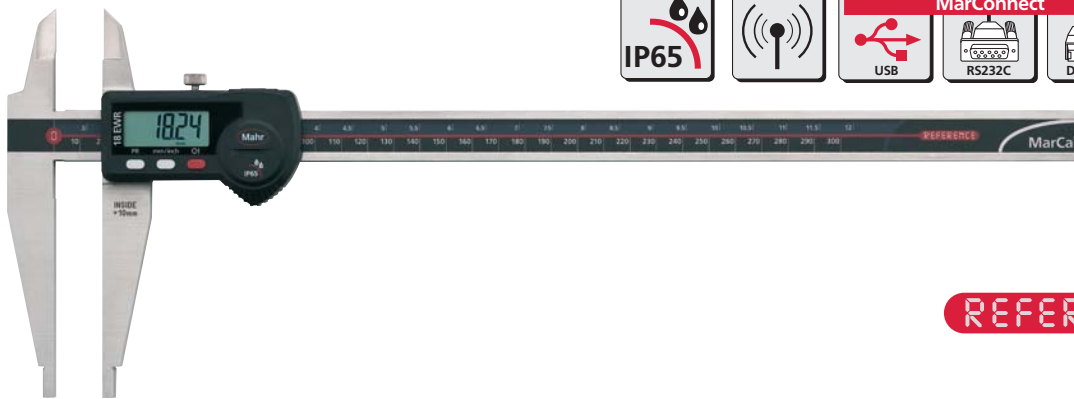

Features

Functions:

ON/OFF
 RESET (Set display to zero)
 mm/inch
 Reference-Lock/Unlock
 DATA (Data transmission via connection cable)
 Auto-ON/OFF

- Immediate measurement due to the Reference system
- Excellent resistance against dust, coolants and lubricants, protection class IP65
- MarConnect data output, choose alternatively: USB, OPTO RS232C or Digimatic
- Dirt wipers are integrated in the slide
- Life of the battery up to 3 years
- Max measuring speed 2.5 m/s (100"/s)
- High contrast LCD with 10 mm (only 300 mm) and 12.5 mm high digits
- Slide and beam made of hardened stainless steel
- Rounded measuring blades for inside measurement
- Locking screw
- Supplied with: Case, battery, operating instructions

Technical Data

Measuring range	Resolution	Error limit G	Weight	Order no.
mm (inch)	mm / inch	mm/inch	kg	
300 (12")	0.01 / .0005"	0.03/ .001"	0.45	4112704
500 (20")	0.01 / .0005"	0.04/ .0015"	1.10	4112712
750 (30")	0.01 / .0005"	0.05/ .0020"	1.35	4112714
1000 (40")	0.01 / .0005"	0.06/ .0024"	2.20	4112716

Dimensions

mm	a	b	c	d	e	f
300	410	90	10	10	20 x 4.5	40
500	650	150	20	20	25 x 5.5	55
750	905	150	20	20	25 x 5.5	55
1000	1165	150	20	20	30 x 6.5	60

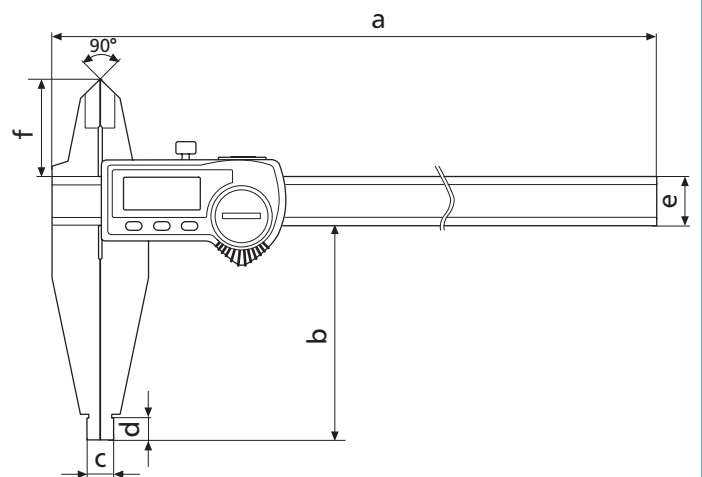

Accessories

	Order no.
Battery 3V, Type CR 2032	4102520
Data Connection Cable USB (2 m)	16 EXu 4102357
Data Connection Cable Opto RS232C (2 m), with SUB-D jack 9-pin	16 EXr 4102410
Data Connection Cable Digimatic (2 m), Flat plug 10-pin	16 EXd 4102411

Accessories for Data Processing see Chapter 11

Digital Caliper MarCal 18 ESA lightweight construction



Features

Functions:

ON/OFF
 RESET (Zero setting)
 mm/inch
 HOLD (storage of measured values)
 DATA (Data transmission)

- Dirt wipers are integrated in the slide
- Max measuring speed 1.5 m/sec (60"/sec)
- Data output: Opto RS232C (only 300 mm version)
- High contrast Liquid Crystal Display with 6 mm or 10.5 mm high digits
- To reduce the overall weight the slide and beam are made from aluminum and are coated with a hard anodized surface coating (1100HV)
- Measuring faces are made of hardened stainless steel
- Prisma guide ways for a more smooth and even movement
- Measuring blades for outside measurement
- Rounded measuring faces for inside measurement
- Locking screw
- Supplied with: Case

Technical Data

Measuring range		Resolution	Error limit G		Weight	Order no.
mm	(inch)	mm / inch	mm/inch		kg	
300	(12")	0.01 / .0005"	0.03/ .001"	•	0.50	4112620
500	(20")	0.01 / .0005"	0.03/ .001"	-	1.40	4112621
800	(32")	0.01 / .0005"	0.07/ .0025"	-	1.60	4112622
1000	(40")	0.01 / .0005"	0.08/ .0032"	-	1.80	4112623

Dimensions

mm	a	b	c	d	e	f	g	h	i
300	450	33	90	24.5	10	10	25	4.5	17
500	726	42	150	33.5	15	20	31.9	6	29
800	1026	42	150	33.5	15	20	31.9	6	29
1000	1226	42	150	33.5	15	20	31.9	6	29

Accessories

	Order no.
Battery 3V, Type CR 2032	4102520
Data Connection Cable Opto RS232C (2 m), with SUB-D jack 9-pin	16 ESv 4102510
Accessories for Data Processing see Chapter 11	

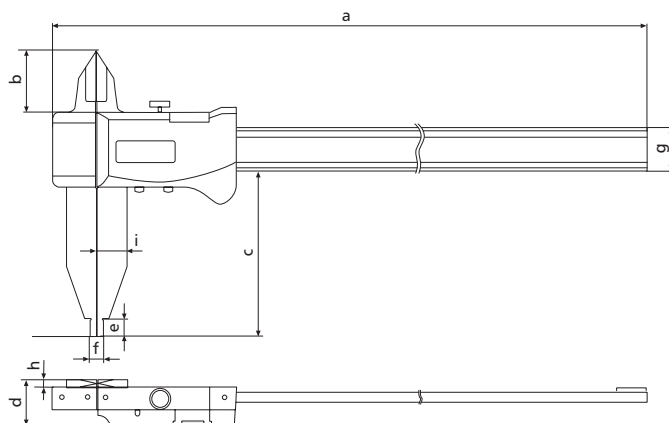

Caliper MarCal 18 NA lightweight construction



Features

- To reduce the overall weight the slide and beam are made from aluminum and are coated with a hard anodized surface coating (1100HV)
- Measuring faces are made of hardened stainless steel
- Measuring blades for outside measurement
- Supplied with: Case, over 1500 mm supplied in a cardboard box
- Prisma guide ways for a more smooth and even movement
- Rounded measuring faces for inside measurement
- Locking screw

Technical Data

Measuring range mm	Readings		Error limit G mm	Weight kg	Order no.
	upper mm	lower mm			
300	0.02	0.02	0.03	0.50	4112300
500	0.02	0.02	0.03	1.40	4112301
800	0.02	0.02	0.07	1.60	4112302
1000	0.02	0.02	0.08	1.75	4112303
1500	0.05	0.05	0.16	2.10	4112304
2000	0.05	0.05	0.16	2.50	4112305

Dimensions

mm	a	b	c	d	e	f	g	h	i
300	450	33	90	17.5	10	10	25	4.5	17
500	726	42	150	20.7	15	20	31.9	6	29
800	1026	42	150	20.7	15	20	31.9	6	29
1000	1226	42	150	20.7	15	20	31.9	6	29
1500	1760	85	200	25	15	30	48.1	6	40
2000	2260	85	200	25	15	30	48.1	6	40

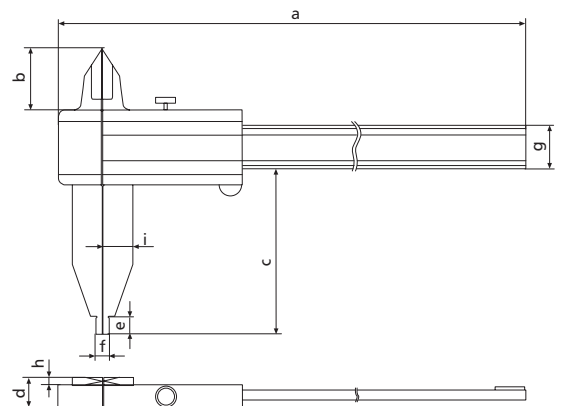

Vernier Caliper MarCal 18 N

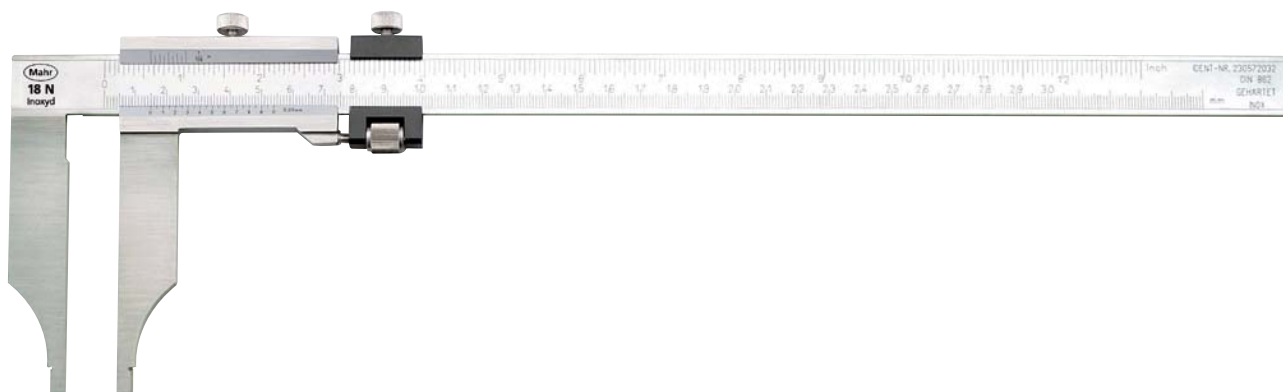

Features

- Vernier and main scale have a satin chrome finish for glare free reading
- Slide and beam made of hardened stainless steel
- Rounded measuring faces for inside measurement
- Supplied with: up to 1000 mm delivered with a case, over 1000 mm individually packed
- Raised guide ways for the protection of the scale
- Locking screw

Technical Data

Measuring range mm (inch)	Resolution		Error limit mm	G DIN 862	Order no. without fine adjustment	Order no. with fine adjustment
	upper	lower				
200	0.02 mm	0.02 mm	0.05		4112200	
300	0.02 mm	0.02 mm	0.05		4112201	4112220
300 (12")	.001"	0.02 mm	0.05			4112230
500	0.02 mm	0.02 mm	0.06			4112221
500 (20")	.001"	0.02 mm	0.06			4112231
500	0.05 mm	0.05 mm	0.07	●	4112210	
800	0.02 mm	0.02 mm	0.08			4112222
800 (32")	.001"	0.02 mm	0.08			4112232
800	0.05 mm	0.05 mm	0.10	●	4112211	
1000	0.02 mm	0.02 mm	0.08			4112223
1000 (40")	.001"	0.02 mm	0.08			4112233
1000	0.05 mm	0.05 mm	0.12	●	4112212	
1500	0.02 mm	0.02 mm	0.10			4112224
1500 (60")	.001"	0.02 mm	0.10			4112234
1500	0.05 mm	0.05 mm	0.18	●	4112213	
2000	0.02 mm	0.02 mm	0.12			4112225
2000 (80")	.001"	0.02 mm	0.12			4112235
2000	0.05 mm	0.05 mm	0.22	●	4112214	

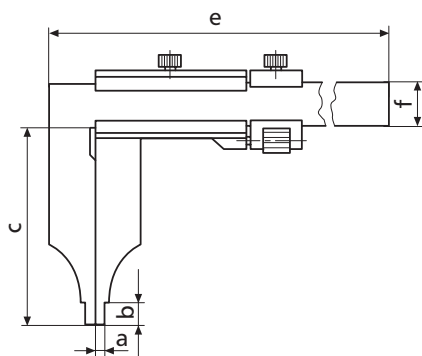

Dimensions

mm	a	b	c	e	f
18 N					
200 mm	5	10	80	310	20 x 5
300 mm	5	10	90	410	20 x 5
500 mm	10	19	150	675	25 x 6
800 mm	10	19	150	985	30 x 7
1000 mm	10	19	150	1185	30 x 7
1500 mm	15	19	200	1760	40 x 8
2000 mm	15	19	200	2270	45 x 10

Vernier Caliper MarCal 18 DN with measuring blades for outside measurement

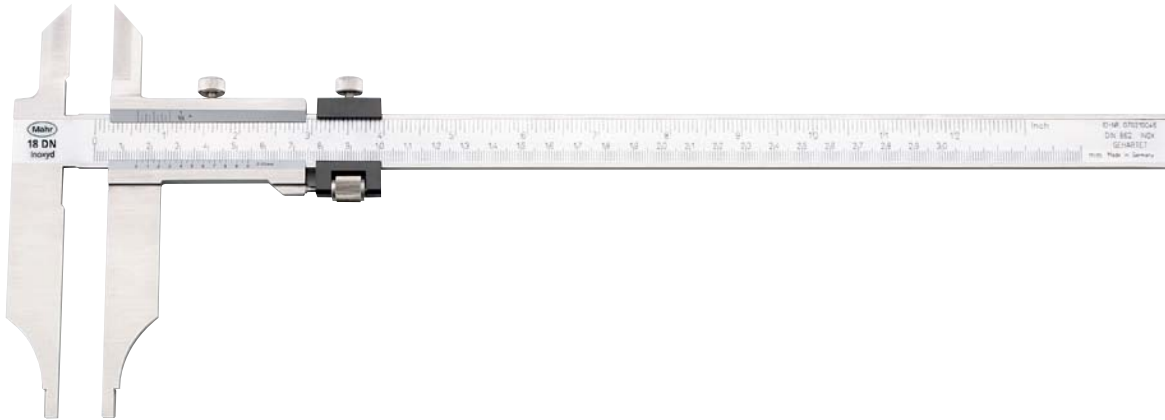

Features

- Vernier and main scale have a satin chrome finish for glare free reading
- Slide and beam made of hardened stainless steel
- Rounded measuring faces for inside measurement
- Locking screw
- Supplied with: up to 1000 mm delivered with a case, over 1000 mm individually packed
- Raised guide ways for the protection of the scale

Technical Data

Measuring range mm	Resolution		Error limit <i>G</i> mm	DIN 862	Order no. without fine adjustment	Order no. with fine adjustment
	upper	lower				
200	0.05 mm	0.05 mm	0.05	●	4113200	
200	0.02 mm	0.02 mm	0.05			4113300
300	0.05 mm	0.05 mm	0.05	●	4113201	
300	0.02 mm	0.02 mm	0.05			4113301
500	0.05 mm	0.05 mm	0.07	●	4113202	
500	0.02 mm	0.02 mm	0.06			4113302
800	0.05 mm	0.05 mm	0.10	●	4113203	
800	0.02 mm	0.02 mm	0.08			4113303
1000	0.05 mm	0.05 mm	0.12	●	4113204	
1000	0.02 mm	0.02 mm	0.08			4113304
1500	0.05 mm	0.05 mm	0.18	●	4113205	
2000	0.05 mm	0.05 mm	0.22	●	4113206	

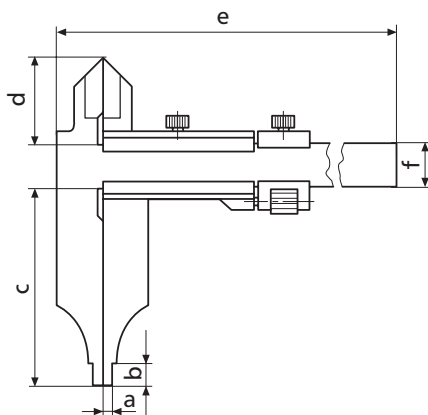

Dimensions mm

	a	b	c	d	e	f
18 DN	200 mm	5	10	80	40	310
	300 mm	5	10	90	40	410
	500 mm	10	19	150	60	675
	800 mm	10	19	150	65	985
	1000 mm	10	19	150	67	1185
	1500 mm	15	19	200	86	1760
2000 mm	25	19	200	96	2270	

Digital Depth Gage MarCal 30 EWR according to protection class IP67

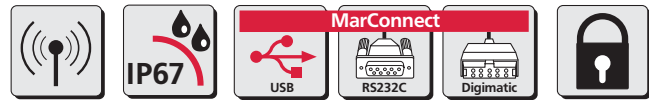

REFERENCE

Merkmale

Functions:

ON/OFF
 RESET (Set display to zero)
 mm/inch
 PRESET (enter a numerical value)
 Reference-Lock/Unlock
 Auto-ON/OFF

- Immediate measurement due to the Reference system
- Excellent resistance against dust, coolants and lubricants, protection class IP67
- MarConnect data output, choose alternatively: USB, OPTO RS232C or Digimatic
- Dirt wipers are integrated in the slide
- Life of the battery up to 3 years
- Max measuring speed 2.5 m/s (100"/s)
- High contrast LCD with 8.5 mm high digits
- Lapped guide way
- Beam and cross beam are made of hardened stainless steel
- Locking screw
- Supplied with: Case, battery, operating instructions

Technical Data

Measuring range	Resolution	Error limit	Order no.
mm (inch)	mm/inch	mm/inch	
150 (6")	0.01 / .0005"	0.03 / .001"	4126700
300 (12")	0.01 / .0005"	0.04 / .0015"	4126701
500 (20")	0.01 / .0005"	0.05 / .0020"	4126702

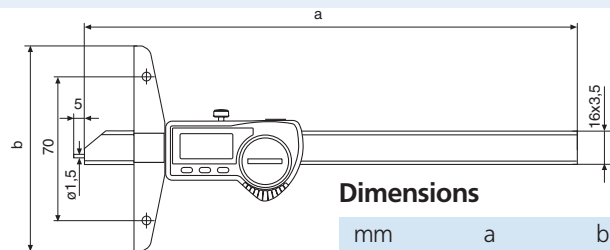

Dimensions

mm	a	b
150	234	100
300	384	150
500	584	150

Depth measurement

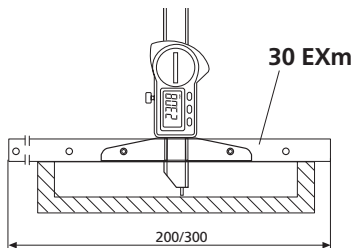

Distance measurement

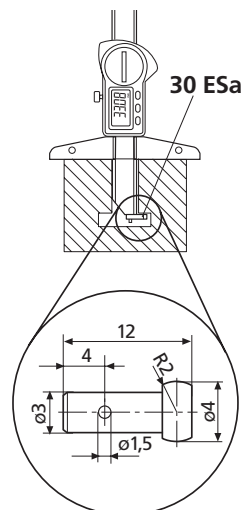

Accessories

	Order no.
Battery 3V, Type CR 2032	4102520
Data Connection Cable USB (2 m)	16 EXu 4102357
Data Connection Cable Opto RS232C (2 m), with SUB-D jack 9-pin	16 EXr 4102410
Data Connection Cable Digimatic (2 m), Flat plug 10-pin	16 EXd 4102411
Cross Beam Extension 200 mm	30 EXm 4126511
300 mm	30 EXm 4126510
Anvil for distance measurement to be fixed to the measuring pin	30 ESa 4125611

Accessories for Data Processing see Chapter 11

Digital Depth Gage MarCal 30 ER



REFERENCE

Features

Functions:

- ON/OFF
- RESET (Set display to zero) mm/inch
- PRESET (enter a numerical value)
- Reference-Lock/Unlock
- Auto-ON/OFF
- Immediate measurement due to the Reference system

- MarConnect data output, choose alternatively: USB, OPTO RS232C or Digimatic
- Dirt wipers are integrated in the slide
- Life of the battery up to 3 years
- Max measuring speed 2.5 m/s (100"/s)

- High contrast LCD with 8.5 mm high digits
- Lapped guide way
- Beam and cross beam are made of hardened stainless steel
- Locking screw

- Supplied with: Case, battery, operating instructions

Technical Data

Measuring range		Resolution	Error limit	Order no.
mm	(inch)	mm/inch	G mm/inch	
150	(6")	0.01 / .0005"	0.03/ .001"	4126514
300	(12")	0.01 / .0005"	0.04/ .0015"	4126515
500	(20")	0.01 / .0005"	0.05/ .0020"	4126516

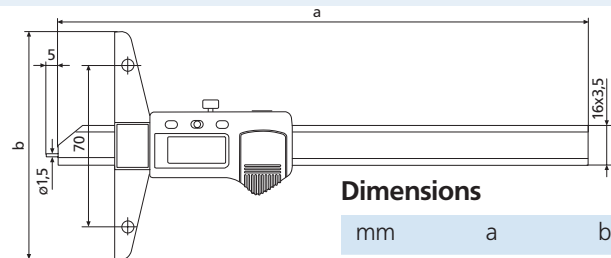

Dimensions

mm	a	b
150	234	100
300	384	150
500	584	150

Depth measurement

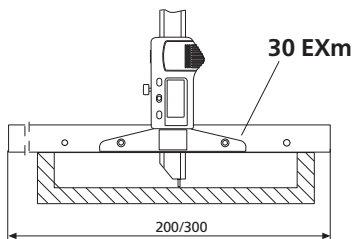

Distance measurement

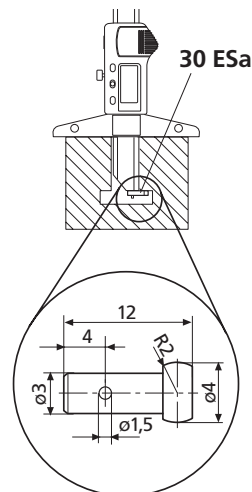

Accessories

	Order no.
Battery 3V, Type CR 2032	4102520
Data Connection Cable USB (2 m)	16 EXu 4102357
Data Connection Cable Opto RS232C (2 m), with SUB-D jack 9-pin	16 EXr 4102410
Data Connection Cable Digimatic (2 m), Flat plug 10-pin	16 EXd 4102411
Cross Beam Extension 200 mm	30 EXm 4126511
300 mm	30 EXm 4126510
Anvil for distance measurement to be fixed to the measuring pin	30 ESa 4125611

Accessories for Data Processing see Chapter 11

Digital Depth Gage MarCal 30 EWN



Version A

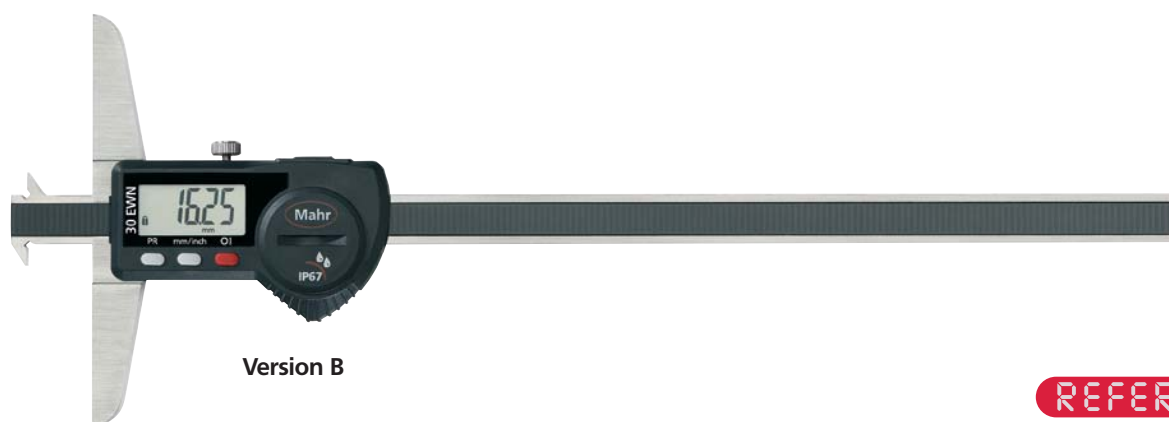

Version B

REFERENCE

Applications

- Ideal for measuring the width of grooves and distances between grooves

Features

Functions:

- ON/OFF
- RESET (Set display to zero)
- mm/inch
- PRESET (enter a numerical value)
- Reference-Lock/Unlock
- Auto-ON/OFF

- Immediate measurement due to the Reference system
- Excellent resistance against dust, coolants and lubricants, protection class IP67
- MarConnect data output, choose alternatively: USB, OPTO RS232C or Digimatic

- Dirt wipers are integrated in the slide
- Life of the battery up to 3 years
- Max measuring speed 2.5 m/s (100"/s)
- High contrast LCD with 8.5 mm high digits

- Beam and cross beam are made of hardened stainless steel
- Locking screw
- Supplied with: Case, battery, operating instructions. Version A: Anvils 30 ENt (1 mm), 902 and 903,

Technical Data

Measuring range		Length of cross beam	Resolution G	Error limit	Version	Order no.
mm	(inch)					
100	(4")	85/ 3.35"	0.01/ .0005"	0.03/ .001"	A	4126512
200	(8")	100/ 3.93"	0.01/ .0005"	0.03/ .001"	B	4126517
300	(12")	150/ 6"	0.01/ .0005"	0.03/ .001"	B	4126518

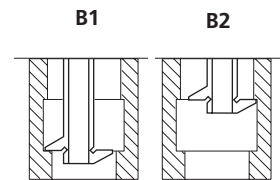
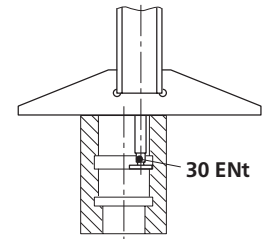
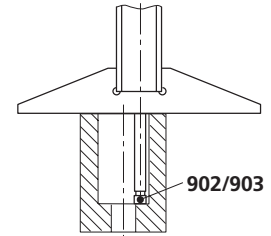
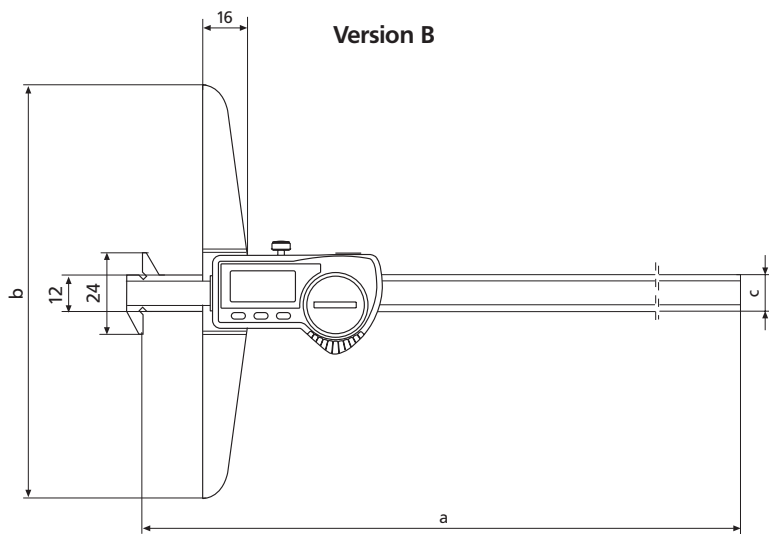
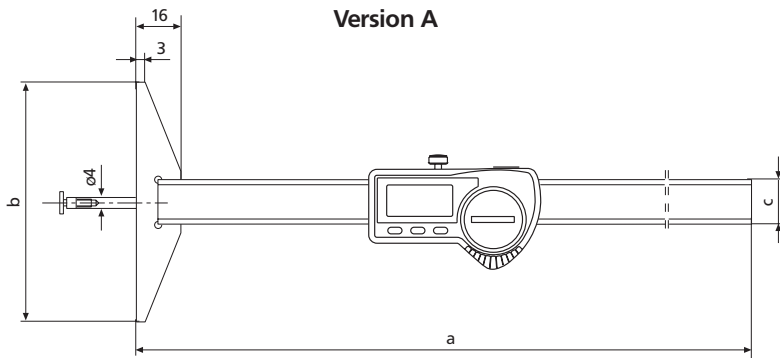

Dimensions

mm	a	b	c
100	268	85 x 8.5	16 x 3
200	281	100 x 8.7	11.5 x 3.6
300	381	150 x 8.7	11.5 x 3.6

Accessories

	Order no.
Battery 3V, Type CR 2032	4102520
Data Connection Cable USB (2 m)	16 EXu 4102357
Data Connection Cable Opto RS232C (2 m), with SUB-D jack 9-pin	16 EXr 4102410
Data Connection Cable Digimatic (2 m), Flat plug 10-pin	16 EXd 4102411
Disc Type Anvil 0.5 mm thick, hardened	30 ENT 4126310
Disc Type Anvil 1 mm thick, hardened	30 ENT 4882022

Accessories for Data Processing see Chapter 11

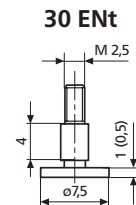
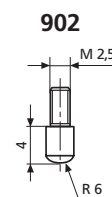
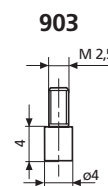

Depth Gages MarCal 30 N / 30 NH / 30 ND

DIN
862

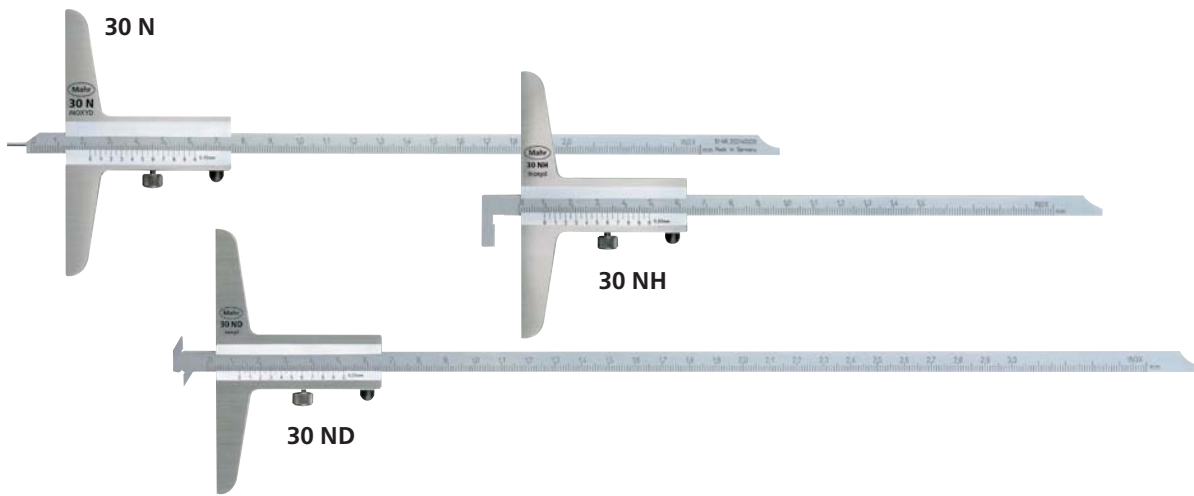

Features

- Vernier and main scale have a satin chrome finish for glare free reading
- Slide, beam and cross beam are made of hardened stainless steel
- Raised guide ways for the protection of the scale
- Supplied with: Case
- Locking screw

Technical Data

Measuring range mm	Vernier scale mm	Error limit G mm	Order no. 30 N with hardened measuring pin	Order no. 30 NH with hook	Order no. 30 ND with twin hook
80	0.05	0.05	4127200		
150	0.05	0.05	4127300	4127350	
200	0.05	0.05	4127301	4127351	4127410
300	0.05	0.05	4127201	4127352	4127411
500	0.05	0.07	4127202	4127353	

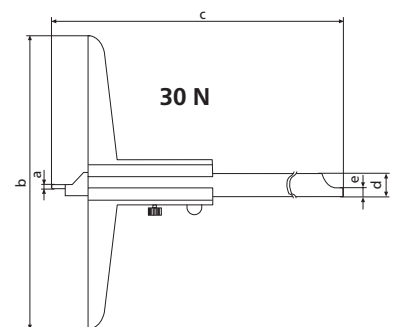
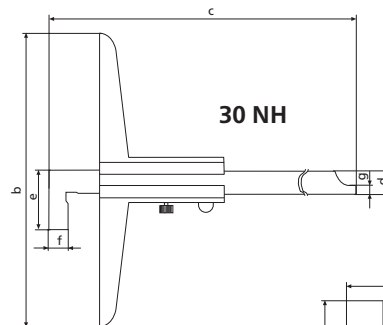
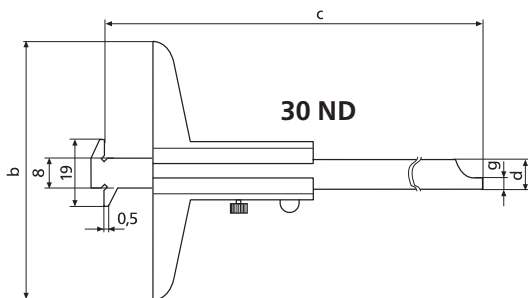

Dimensions

mm	dia. a	b	c	d	e	f	g
80 mm	1	50	140	8 x 3	-	-	-
150 mm	1.5	100	235	8 x 3	20	5	3.5
200 mm	1.5	100	285	8 x 3	20	5	3.5
300 mm	2.0	150	390	12 x 4	28	10	4
500 mm	2.0	150	590	12 x 4	28	10	4

DO YOU WANT TO AIM EVEN HIGHER? FOR THIS THERE IS DIGIMAR.



The latest information on DIGIMAR products can be found on our website:

www.mahr.com, WebCode 204

















► | Mahr offers you a complete range of products in order for you to obtain the most reliable solution for all your measuring tasks. Whether it's simply scribing a work piece or complex measurements in two dimensions - Digimar Height Measuring Instruments guarantee a maximum of both flexibility and quality. Our motorized Height Measuring Instruments Digimar 817 CLM and 816 CL exceed all customer requirements; they are simple to operate, all the basic functions can be executed with a single key as well as offering a maximum of ease and accuracy.

► | Digimar. Height Measuring Instruments

Overview	
Digimar Height Measuring Instruments	2- 2
Motorized Height Measuring Instruments	
Digimar 817 CLM Quick Height	2- 4
High-End Height Measuring Instrument with 2D and Statistics function	
Digimar 816 CL	2- 8
Height Measuring Instrument for the workshop and test labs	
Accessories for 817 CLM and 816 CL	2-10
Manual Height Measuring Instruments	
Digimar M 814 N	2-16
With Cast Iron Base	
Digimar M 814 G	2-17
With Granite Table Plate	
Accessories for Digimar M 814	2-18
Height Measuring and Scribing Instrument	
Digimar 814 SR	2-19

Digimar. Height Measuring Instruments

OVERVIEW

	Digimar 817 CLM „Quick Height“					
						
	2-4	2-4	2-4	2-4	2-4	2-4
Catalog page	2-4	2-4	2-4	2-4	2-4	2-4
Measuring range mm/inch	0-350 / 0-14"		0-600 / 0-24"		0-1000 / 0-40"	
Application range up to mm/inch	520 / 20.47"		770 / 30.35"		1170 / 46.06"	
Measuring error* in µm	1.8+L/600 (L in mm)		1.8+L/600 (L in mm)		1.8+L/600 (L in mm)	
Quick Mode	●		●		●	
1-D 	●		●		●	
2-D	-	●	-	●	-	●
Motorized measuring carriage	●		●		●	
Scribing/marketing work pieces 	-		-		-	
Bore diameter 	●		●		●	
Max-Min 	●		●		●	
Tolerance monitoring 	●		●		●	
Perpendicularity measurement 	●		●		●	
Straightness measurement 	●		●		●	
Angle calculation 	-	●	-	●	-	●
Statistics 	-	●	-	●	-	●
Measuring programs 	40		40		40	
Temperature compensation 	●		●		●	
Air bearings	●		●		●	
Integrated USB memory 	●		●		●	
Data interface	RS232		RS232		RS232	
USB printer interface 	●		●		●	
Order no.	4429000	4429010	4429001	4429011	4429002	4429012

* in conjunction with standard accessories

Digimar 817 CLM Quick Height

► | The new Height Measuring Instrument **Digimar 817 CLM** with the innovative Quick Mode. Highly accurate rapid measurements, a wide range of measuring and evaluation options and excellent operator comfort. | ◀

The best solution for all measuring tasks



Fast measurement per hand
Easy to operate due to the „Quick Mode“; an innovative solution from Mahr (patented).



Ill. 1. Move the measuring carriage by hand in the direction of the object to be measured.



Ill. 2. The motor starts, the measurement procedure will automatically be performed.

Measurement using the keypad (speed keys) on the base



Ideal in conjunction with the air bearings for large work pieces.

By using the keys that are integrated into the base; the operator can comfortably move the measuring carriage into the desired position and start a measurement. This eases measurement particularly when measuring large workpieces as these do not have to be moved into position. The operator can keep both hands on the measuring instrument (one hand on the key for the air bearing and other on the high-speed keys) and measure the workpiece in one run.



Highest accuracy and reliability

- Extremely accurate incremental measuring system with double reader head system, insensitive to the contamination of dirt
- Robust guide column, made from stainless steel
- Measuring head in precision ball bearings guide
- Temperature compensation with an integrated temperature sensor

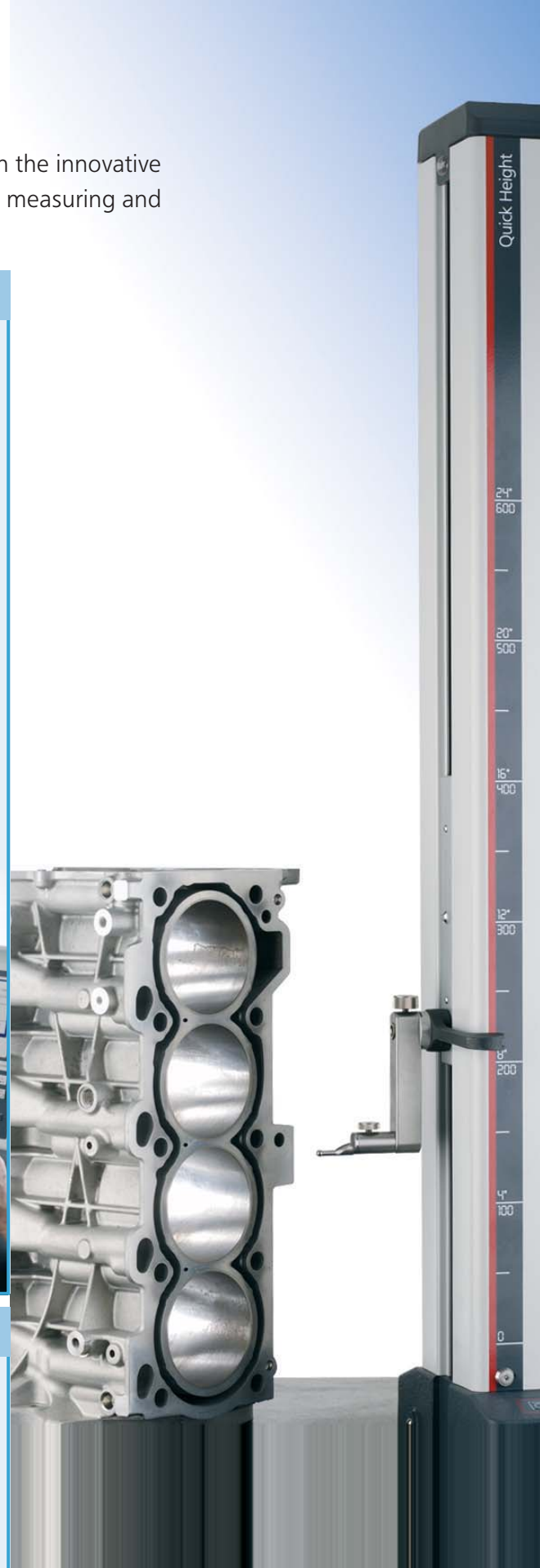

Digimar 817 CLM



Ergonomic operating and display unit

Choose either as 1D or 2D / Stat operating and display units

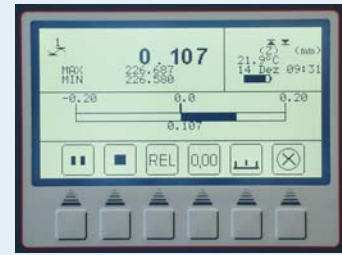

- Large, back-lit display
- Self-explanatory guided operation with icons



- The display unit can be positioned freely with the swivel arm

Easy to operate all measurement functions with the function keys due to the clearly defined symbols.

Universal measurement possibilities

- Wide range of measurement functions in 1D or 2D (optional)
- Dynamic measurement functions with the analog display
- Automatic perpendicularity and straightness measurements (in conjunction with accessories)
- Automated measuring procedures (measurement programs)
- Auto function for chain measurements and distance measurements

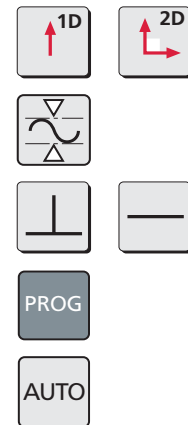

Extensive evaluation possibilities

- Transmit data to a PC via RS232 or USB (with an adapter) for example into MS Excel via the MarCom-Software
- Print measured values, statistics, etc. via a USB printer
- Save measured values in the integrated USB memory (will be recognized by a PC as an interchangeable disc drive)
- Broad range of statistical evaluations are available (optional)

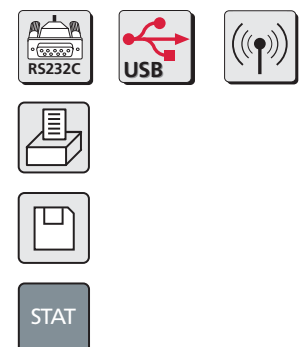

Height Measuring Instrument Digimar 817 CLM



See our brochure at
WebCode 12369



Features

Measuring system

- Excellent accuracy and reliability due to the optical incremental measurement system with the double reader head
- Dynamic probing system enabling high repeatability
- Air bearings system for light and smooth movement
- Precise measuring head on stainless steel guideways
- Motorised measuring carriage simplifies measurement runs
- Probe constant remains after the instrument is switched off
- Integrated rechargeable battery with a long operating time span for mains independent measurement
- Temperature compensation with an integrated temperature sensor

Operating and display unit

- Large and clearly defined function keys
- Easy to read background lit graphic LCD-Display
- Operator guidance with self-explanatory icons / pictograms
- Operator prompts and menus are available in several languages
- Possible to set additional zero points on a work piece
- RS232 and / or USB data output for further data processing
- Save measured data on the integrated USB memory
- USB interface to connect a compatible USB printer
- Additional measuring instruments with Opto RS232-interface can be connected
- Secure the future due to software update potential
- Automatic Stand-by switch mode
- Selectable Auto-off function, without loss of measured values

- Supplied with:
Height Measuring Instrument incl. operating and display unit,
Carrier 817h1,
Probe K6/51
Setting block 817 eb,
Operating instructions,
Mains power adapter,
USB cable

Technical Data

Measuring range	mm / inch	350 / 14"	600 / 24"	1000 / 40"
Range of application	mm / inch	520 / 20.47"	770 / 30.31	1170 / 46.06
Resolution	mm inch	0.01 / 0.005 / 0.001 / 0.0005 / 0.0001 0.001" / 0.0005" / 0.0001" / 0.00005" / 0.00001"		
Measuring error*	µm		(1.8+L/600), L in mm	
Repeatability	µm		0.5 (plane) 1 (bore)	
Perpendicularity error (elect. adjusted)	µm	frontal ≤5	frontal ≤6	frontal ≤10
Operating time of rechargeable battery	h		up to 16	
Measuring force	N		1.0 ± 0.2	
Permissible relative air humidity	%		65 (non condensed)	
Working temperature	°C / °F		20 ± 1 / 68 ± 33.8	
Operating temperature	°C / °F		10 ... 40 / 50 ... 104	
3-point air cushion, height	µm		ca. 9	
Measuring system			incremental scale with optical reading	
Total height	mm / inch	741 / 29.17"	985 / 38.78"	1392 / 54.80"
Base area (L x W)	mm / inch		240 x 250 / 9.45" x 9.84"	
Weight	kg / lbs	25 / 55.15	30 / 66.14	35 / 77.16
Order no. 1D		4429000	4429001	4429002
Order no. 2D / Stat		4429010	4429011	4429012

* Surface base plate according to DIN 876/0 with standard accessories

Height Measuring Instrument Digimar 817 CLM

Operating and display unit

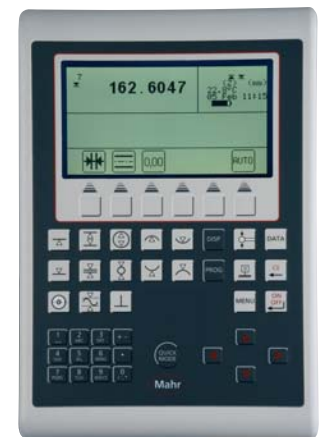
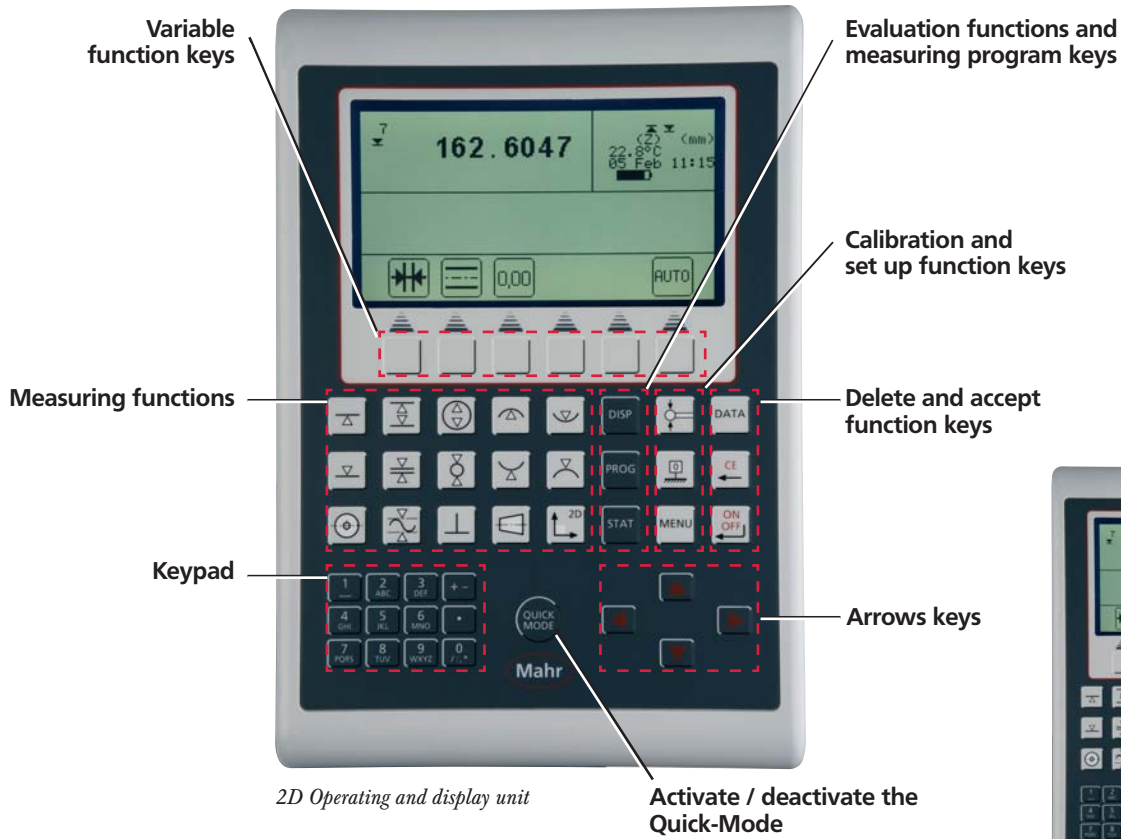

Operating and display unit		1D	2D / Stat
Measurement			
One dimensional (1D)		●	●
Two dimensional (2D)			●
Measuring programs (automatic run)		40	40
Perpendicularity / straightness measurement		●	●
Flatness / parallel deviation (Max, Min)		●	●
Roundness / run-out deviation (Max-Min)		●	●
Measuring a taper			●
Evaluation			
- Statistics			●
- Transmit measured values to a PC via RS232		●	●
- Print measured values and diagrams on a USB printer		●	●
- Print out statistical evaluations			●
- Save measured values on the integrated USB memory		●	●

Digimar 816 CL

► | The new Height Measuring Instrument **Digimar 816 CL**.

You want to obtain highly accurate measurement results without any complicated procedures? With the Digimar 816 CL you have the perfect partner for simple and accurate measurements both in the workshop or on the production line, just as you expect from Mahr! | ◀

User-friendly operation. . .

. . .due to the

- Clearly displayed measured values
- Self-explanatory operator guidance



The operating and display unit has a background illuminated display.

Precise measuring results. . .

. . . on the production line

- Robust design
- Measuring results independent of the user
- Reliable results even outside of the inspection room



Probe contact with the motorized measuring carriage.

- 
 • Temperature compensation with an integrated temperature sensor

Versatile

The Height Measuring Instrument Digimar 816 CL offers numerous practical measuring and evaluation functions:

- Convenient standard measuring functions



- Dynamic measuring functions

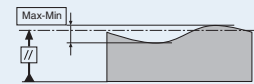

Parallel deviation

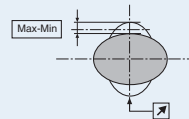

Roundness deviation

- Wide range of options for data evaluation



The measuring program. . .

. . . is essential for repetitive part measurement



- Repetitive measuring procedures can easily be automated
- Simply create a measuring program with the Teach-In-mode
- Complex procedures can be started by just pressing one key



Height Measuring Instrument Digimar 816 CL



Features

Measuring system

- Excellent accuracy and reliability due to the optical incremental measurement system with the double reader head
- Dynamic probing system enabling high repeatability
- Air bearings system for light and smooth movement
- Precise measuring head on stainless steel guideways
- Motorized measuring carriage simplifies measurement runs
- Temperature compensation with an integrated temperature sensor
- Probe constant remains after the instrument is switched off
- Integrated rechargeable battery with a long operating time for mains independent measurement

Operating and display unit

- Easy to read background lit graphic LCD-Display
- Large and clearly defined function keys
- Operator guidance with self-explanatory icons / pictograms
- Possible to set additional zero points on a work piece
- Memory can store up to 99 measured values
- MarConnect data output, select either:
 - USB
 - OPTO RS232C
- Supplied with:
 - Height Measuring Instrument incl. operating and display unit,
 - Carrier 817h1,
 - Probe K6/51,
 - Setting block 817 eb,
 - Operating instructions,
 - Mains power adapter

Technical Data

Measuring range	mm / inch	350 / 14"	600 / 24"
Range of application	mm / inch	540 / 21.26"	770 / 30.31"
Resolution	mm (inch)	0.01 / 0.001 (.0001" / .00005")	
Measuring error*	µm	(2.8+L/300), L in mm	
Repeatability	µm	2 (plane) 3 (bore)	
Perpendicularity error (mech.)	µm	frontal ≤15	frontal ≤20
Operating time of rechargeable battery	h	up to 14	
Measuring force	N	1.0 ± 0.2	
Permissible relative air humidity	%	65 (non condensed)	
Working temperature	°C / °F	20 ±1 / 68 ±33.8	
Operating temperature	°C / °F	10 ... 40 / 50 ... 104	
3-point air cushion, height	µm	ca. 9	
Measuring system		incremental scale with optical reading	
Total height	mm / inch	741 / 29.17"	985 / 38.78"
Base area (L x W)	mm / inch	240 x 250 / 9.45" x 9.84"	
Weight	kg / lbs	25 / 55.15	30 / 66.14
Order no.		4429030	4429031

* 20°C with surface base plate according to DIN 876/0 and standard probe K6/51

Overview of carriers and probes for Digimar 817 CLM / 816 CL

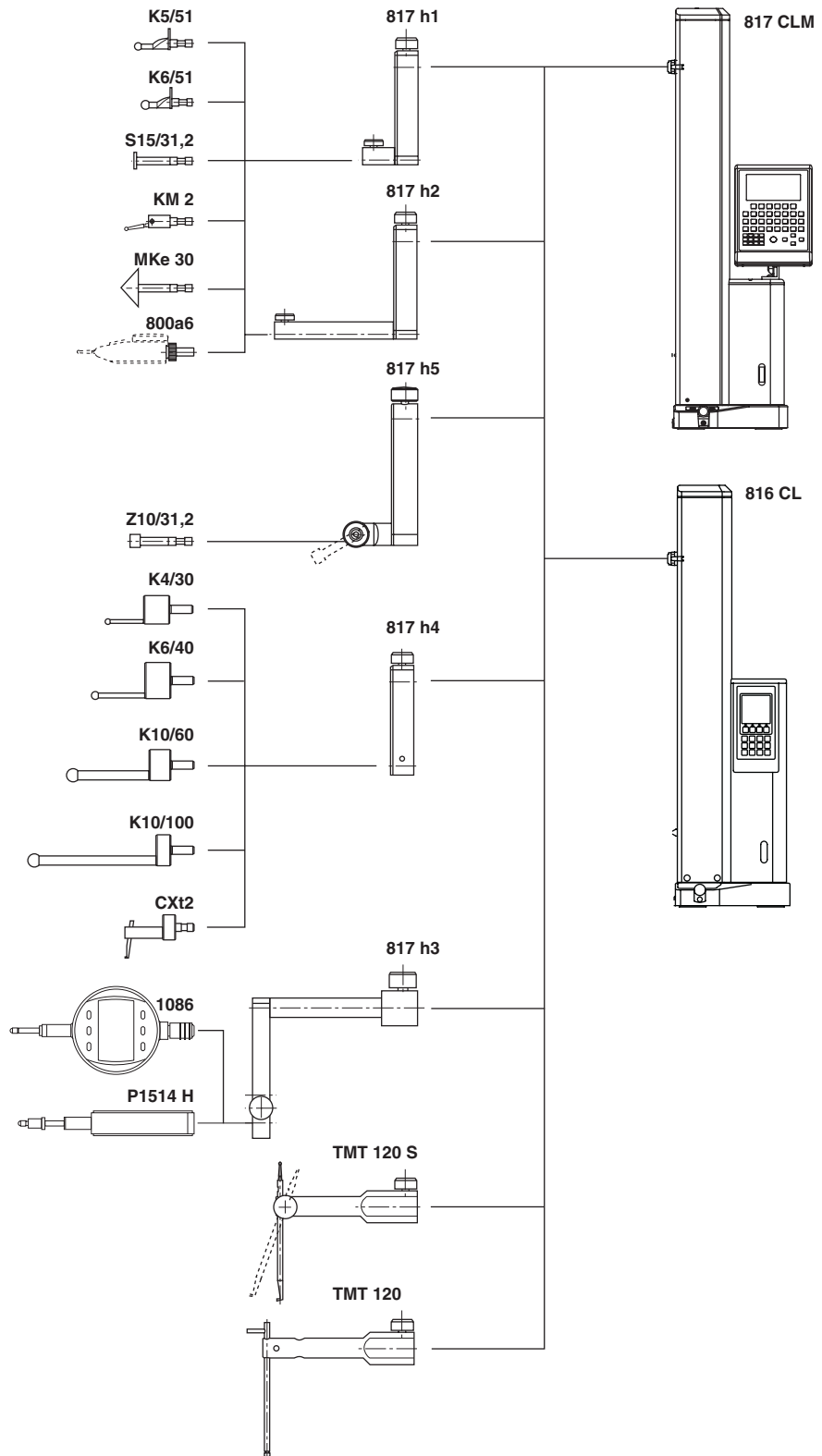

Height Measuring Instruments Digimar 817 CLM / 816 CL

Accessories

Carrier for probes with mount dia. 6 mm

Catalog no.	Description	Shaft length mm	Order no.
817 h1	Carrier for a probe	27.5	4429154*
817 h2	Carrier for a probe	100	4429219
817 h5	Carrier with a joint for a probe	35	4429454

* Supplied with standard accessories

817 h1

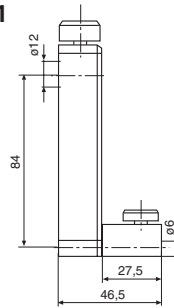

817 h2

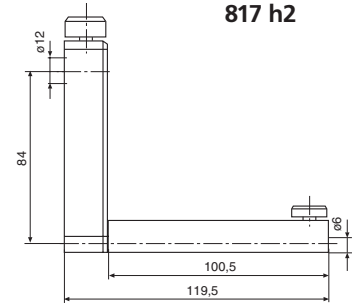

817 h5

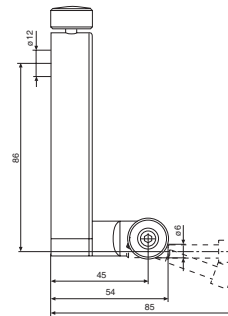

Probes with mount dia. 6 mm

Catalog no.	Description	Order no.
K5/51	Spherical probe	4429158
K6/51	Spherical probe	4429254*
S15/31,2	Disc probe	4429226
Z10/31,2	Cylindrical probe	4429227
MKe 30	Taper probe	4429228
KM 2	Probe M2 incl. styli 800 ts dia. 2 mm	4429256
800 a6	Mounting shaft 800 a6 for MarTest	4301865

* Supplied with standard accessories

K 5/51

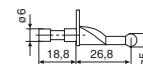

K 6/51

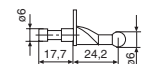

S 15/31,2

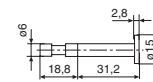

MKe 30

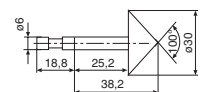

Z 10/31,2

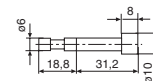

KM 2

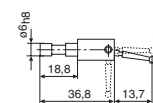

800 a6

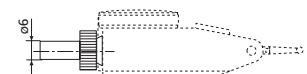

Height Measuring Instruments Digimar 817 CLM / 816 CL

Accessories

Carrier for probes with mount dia. 8 mm

Catalog no.	Description	Order no.
817 h4	Carrier for probes	4429220

817 h4

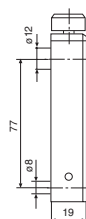

Probes with mount dia. 8 mm

Catalog no.	Ball dia. D mm	Order no.
K4/30	4	7023813
K6/40	6	7023816
K10/60	10	7023810
K10/100	10	7023615

K 6/40

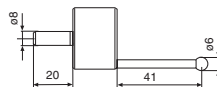

K 4/30

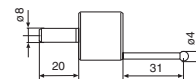

K 10/60

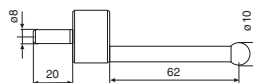

K 10/100



Universal probe set CXt2 see page 2-14

Depth probes

Catalog no.	Description	Order no.
TMT 120	Depth probe incl. carrier	4429221
TMT 120 S	2 depth probes incl. carrier	4429421

TMT 120

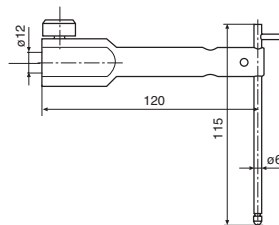

TMT 120 S

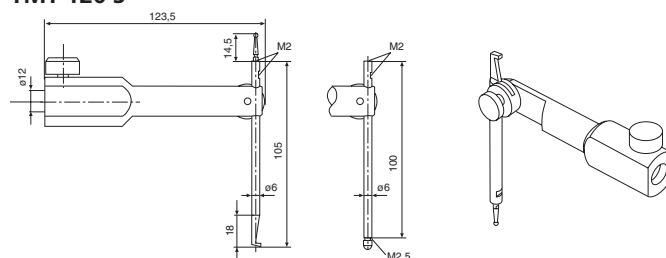

Height Measuring Instruments Digimar 817 CLM / 816 CL

Accessories for checking perpendicularity

Carrier for probes

Catalog no.	Description	Order no.	817 h3
817 h3	Carrier for transducers	4429206	

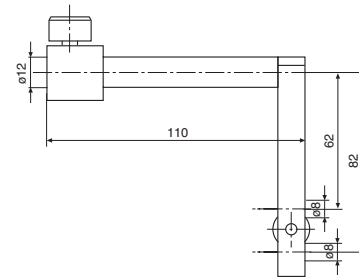

Transducers for checking perpendicularity

Catalog no.	Description	Order no.
P1514 H	Incremental probe, 12 mm incl. cable	4426810*
1086	Digital indicator, 12.5 mm Resolution 0.001 / .00005"	4337020
16 EXr	Data cable for digital indicator 1086	4102410*

* Only for Digimar 817 CLM

817 h3

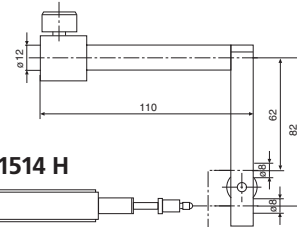

P1514 H

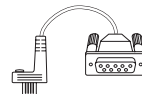
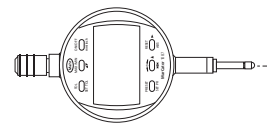

16 EXr

1086

Accessories

Setting blocks

Catalog no.	Description	Order no.	817 eb
817 eb	Setting block	4429168*	
EB I	Setting block for a taper probe, includes a calibration certificate	7023827	

* Supplied with standard accessories



EB I

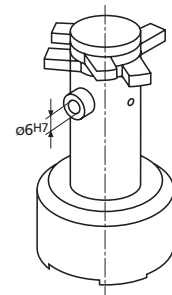

Height Measuring Instruments Digimar 817 CLM / 816 CL

Accessory sets for probes

Probe set 817 ts1 consists of: **4429019**

	Carrying case for accessories	4429020
817 h2	Carrier for probes	4429219
S15/31,2	Disc probe	4429226
Z10/31,2	Cylindrical probe	4429227
MKe 30	Taper probe	4429228
TMT 120	Depth probe incl. carrier	4429221
KM 2	Probe for MarTest styli M2	4429256

817 h4	Carrier for probes	4429220
K4/30	Spherical probe	7023813
K6/40	Spherical probe	7023816
K10/60	Spherical probe	7023810
K10/100	Spherical probe	7023615

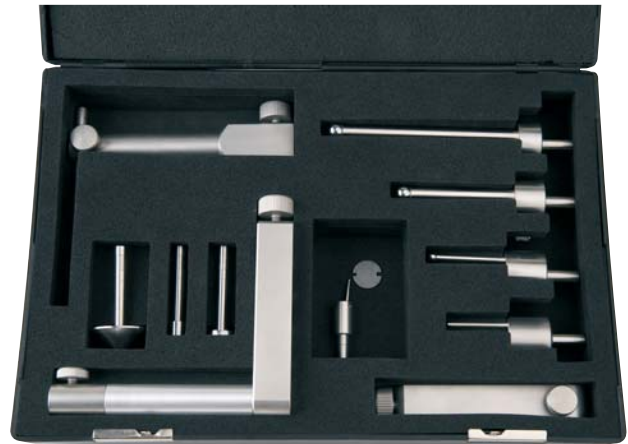

817 ts1

Probe set 817 ts2 consists of: **4429018**

	Carrying case for accessories	4429020
817 h2	Carrier for probes	4429219
S15/31,2	Disc probe	4429226
Z10/31,2	Cylindrical probe	4429227
MKe 30	Taper probe	4429228
TMT 120	Depth probe incl. carrier	4429221
KM 2	Probe for MarTest styli M2	4429256



817 ts2

Universal probe set CXt2 consists of: **7034000**

Case	3015925
Probe carrier	3015917

	Dimension	Shaft length	
Measuring crook	d = 0.5 mm	l = 78 mm	3015918
Probe pin /tip:	dia. d = 1.2 mm	l = 75 mm	3015919
		ls = 15.5 mm	

Taper probe	dia. d = 0–7.5 mm		3015920
Spherical probe	TC dia. dk = 3 mm	l = 24 mm	3022000
Spherical probe	TC dia. dk = 2 mm	l = 24 mm	3022001
Spherical probe	TC dia. dk = 1 mm	l = 24 mm	3022002
Extension M3 – M3	d = 4 mm	l = 20 mm	3015921
Extension M3 – M2.5	d = 4 mm	l = 20 mm	3015888

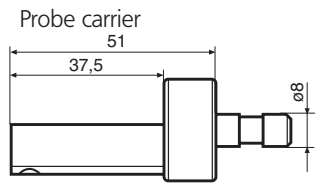

Measuring crook



Pin probe

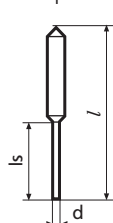

Taper probe

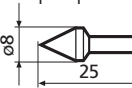

Spherical probe

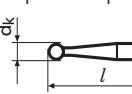

Extension

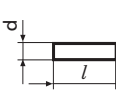

Height Measuring Instruments Digimar 817 CLM / 816 CL

Accessories for data transmission for 816 CL

Data connection cable

	Order no.
Data connection cable incl. MarCom Standard, USB (2 m)	2000 usb 4346023
Data connection cable Opto RS232C (2 m), with SUB-D jack 9-pin	2000 r 4346020

Accessories for Data Processing see Chapter 11

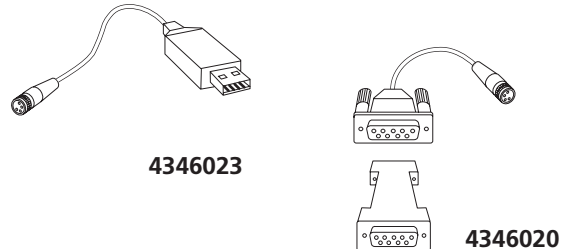

Accessories for data transmission for 817 CLM

Data connection cable

	Order no.
Data cable 817 CLM to MSP 2 / PC	7024634
Adapter cable RS232-USB for Digimar 817 CLM incl. MarCom Standard	4102333

Accessories for Data Processing see Chapter 11

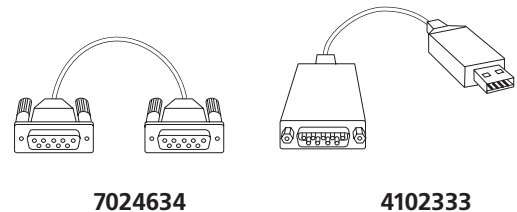

Statistics printer MSP 2 for 816 CL and 817 CLM

- Can be connected via a RS232C interface
 - Two-line display for a simple dialog mode
 - 3 types of print protocols: statistics, statistics with a histogram and sample charts
 - Retrieve at any time from the memory a list of measured values
 - Individual values can be selected and deleted as required.
 - Alternative power sources include: mains adapter (100 - 240 V), batteries or NIMH-accumulator, type AA
 - Languages can be selected, German, English and French
- Supplied with:
Mains adapter, paper rolls



	Order no.
MSP2 Statistics printer	4102040

Printer for 817 CLM

HP Ink jet printer

- Standard connectivity: USB - compatible with USB 2.0 specifications, PictBridge
- Compatible operating systems: Microsoft® Windows® 98 SE, Me, 2000, XP (Home and Professional)
- Standard printer languages HP PCL 3



Similar to illustration

	Order no.
HP Ink jet printer	4429015

Height Measuring and Scribing Instrument Digimar 814 N Standard version

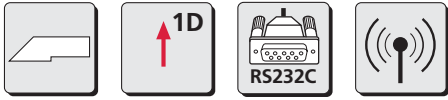

Applications

Ideal for measuring:

- Heights
- Center distances between bores and surfaces, widths of ledges, plus marking and scribing of workpieces

Features

With extra rugged, cast iron base with three-point support. To be used on base plates, machine beds and work piece surfaces. Conversion to a 814 G version is quick and easy at any time.

- High accuracy
- Incremental inductive measuring system
- Measuring head with an ball bush guide
- Resistance free measuring system
- Large, easy to read digital display
- Measuring and display unit are incorporated in the measuring head
- Easy to operate due to the hand crank on the side of the measuring head
- Constant measuring force; acting upwards or downwards as required
- Measuring head can be locked in position, ideal for scribing tasks
- With fine adjustment
- Data transmission via Opto RS232C interface
- Digital Preset
- Zero setting in any position
- MAX, MIN and MAX-MIN functions
- Enter tolerance limit for 1 characteristic
- Switch between mm/inch
- Mains independent due to being battery operated
- Universal application due to a broad range of accessories

Technical Data

Measuring range	mm / inch	320 / 12.6"	620 / 24.4"
Resolution	mm (inch)	0.01 / 0.001 (0.0005" / 0.00005")	
Measuring error	µm	20 / 0.0008"	30 / 0.0012"
Repeatability	µm		5 / 0.0002"
Perpendicularity error	µm	frontal 20 (300 mm)	frontal 30 (600 mm)
Operating time of the battery	h		2000
Measuring force	N		ca. 3
Working temperature	°C / °F		20 ± 1 / 68 ± 33.8
Operating temperature	°C / °F		5 ... 40 / 41 ... 104
Measuring system			inductive
Total height	mm / inch	513 / 20.20"	813 / 32.01"
Cast iron base (L x W)	mm / inch	205 x 175 / 8.07" x 6.89"	205 x 175 / 8.07" x 6.89"
Weight	kg / lbs	6.2 / 13.22	10.5

Order-no.

4426540

4426542

Height Measuring and Scribing Instrument Digimar 814 G Base plate version

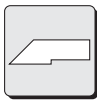

Applications

Ideal for measuring:

- Heights
- Center distances between bores and surfaces, widths of ledges, plus marking and scribing of workpieces

Features

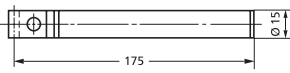
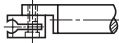
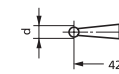
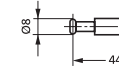
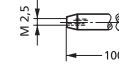

Table plate is made of fine grained black granite (greenstone) which is extremely hard and stable.
Conversion to a 814 N version is quick and easy at any time.

- High accuracy
- Incremental inductive measuring system
- Measuring head with an ball bush guide
- Resistance free measuring system
- Large, easy to read digital display
- Measuring and display unit are incorporated in the measuring head
- Easy to operate due to the hand crank on the side of the measuring head
- Constant measuring force; acting upwards or downwards as required
- Measuring head can be locked in position, ideal for scribing tasks
- With fine adjustment
- Data transmission via Opto RS232C interface
- Digital Preset
- Zero setting in any position
- MAX, MIN and MAX-MIN functions
- Enter tolerance limit for 1 characteristic
- Switch between mm/inch
- Mains independent due to being battery operated
- Universal application due to a broad range of accessories

Technical Data

Measuring range	mm / inch	320 / 12.6"	620 / 24.4"
Resolution	mm (inch)	0.01 / 0.001 (0.0005" / 0.00005")	
Measuring error	µm	20 / 0.0008"	30 / 0.0012"
Repeatability	µm	5 / 0.0002"	
Perpendicularity error	µm	frontal 20 (300 mm)	frontal 30 (600 mm)
Operating time of the battery	h	2000	
Measuring force	N	ca. 3	
Working temperature	°C / °F	20 ± 1 / 68 ± 33.8	
Operating temperature	°C / °F	5 ... 40 / 41 ... 104	
Measuring system		inductive	
Total height	mm / inch	558 / 21.97"	858 / 33.78"
Granite plate (L x W)	mm / inch	200 x 300 / 7.87" x 11.81"	
Grade of accuracy		1 DIN 876	
Weight	kg / lbs	14 / 30.86	18.3 / 35.27
Order-no.		4426541	4426543

Accessories for Height Measuring and Scribing Instrument Digimar 814 N / 814 G

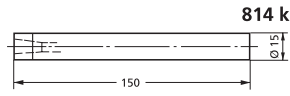
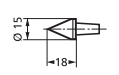
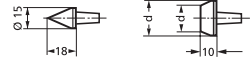
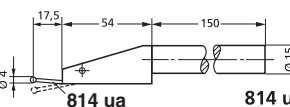
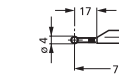
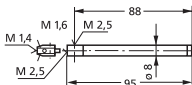
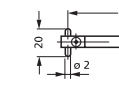
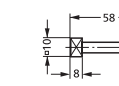
				Order no.	
814 t	Probe arm with joint for mounting probes, dial indicators, and test indicators. Length of mounting shank Mounting bore	150 mm 8 mm	(5.91") (.315")	4426510*	
814 m	Spherical probe To mount in probe arm 814 t	2 mm ball 3 mm ball 4 mm ball 5 mm ball 6 mm ball 7 mm ball 8 mm ball	(.0787") (.118") (.157") (.197") (.236") (.276") (.315")	4426525 4426526 4426512 4426527 4426511 4426528 4426509*	  
814 s	Disc probe for measuring heights, distances, surfaces and edges. Especially recommended for narrow shoulders, e.g. on centering edges.			4426513	
814 h	Probe holder for mounting styli of dial indicators and dial comparators for special applications.	M 2.5		4426514	
814 a	Scriber for scribing and marking of work pieces. Carbide tipped. To be mounted on the Probe arm 814 t			4426515	
814 kh	Holder			4426516	
817 ks1	Measuring taper	0 – 15	(0 - .591")	4426071	
817 ks2	Measuring taper	14 – 20	(.551" - .787")	4426072	
817 ks3	Measuring taper	18 – 24	(.709" - .945")	4426073	
817 ks4	Measuring taper	23 – 30	(.906" - 1.181")	4426074	
814 u	Two direction probe for measuring outside and inside diameters, width of ledges, recesses and slots. Actual ball diameter does not influence the results.	4 mm ball	(.157")	4426517	
814 ua	Interchangeable probe arm for use in conjunction with the two direction probe 814 u	2 mm ball	(.0787")	4426518	
817 Cl-m	Spherical probe	4 mm ball	(.157")	4426436	
817 Cl-am	Holder with connection thread	M 2.5, M 1.6, M 1.4		4426434	
817 Cl-sa	Stylus with exchangeable measuring pin			4426433	
817 Cl-p	Stylus with parallel measuring faces Battery 3 V, type CR 2032			4426435	
	Dust cover	0–320 mm	(0 - 12.60")	4426616*	
	Dust cover	0–620 mm	(0 - 24.41")	4426619*	
814 Nf	Cast iron base			4426506**	
814 Gf	Table plate			4426507**	
814 X	Column with measuring head	320 mm	(0 - 12.60")	4426544	
814 X	Column with measuring head	620 mm	(0 - 24.41")	4426545	
16 Esv	Data connection cable Length 2 m / 6.56 ft	Opto RS232C		4102510	

* Scope of supply
** for upgrade

Height Measuring and Scribing Instrument Digimar 814 SR

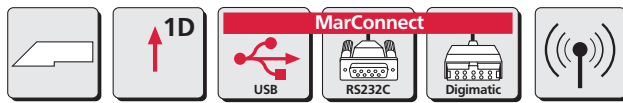

REFERENCE

Application

- Scribing and marking of work pieces
- Measuring heights and distances



Features

Functions:

- RESET (Set the display to zero for relative measurement)
- ABS (Switch between relative and absolute measurement) mm/inch
- Reference-Lock/Unlock
- PRESET (To enter a numerical value)
- DATA (Data transmission via connection cable)
- Auto-ON/OFF
- Life of the battery up to 3 years
- Max. measuring speed 1.5 m/s (60"/s)
- MarConnect Data output: choose either
USB
OPTO RS232C
Digimatic

- High contrast Liquid Crystal Display with 12 mm high digits
- Sturdy heavy-duty base, easy to handle
- Hardened and lapped contact surface which produce both a smooth and even movement
- Slide and beam made of hardened stainless steel
- Hand crank for positioning and measuring
- Fine adjustment
- Locking screw
- Interchangeable scriber point, carbide tipped
- Scope of supply: Scriber point, cardboard box, battery and operating instructions

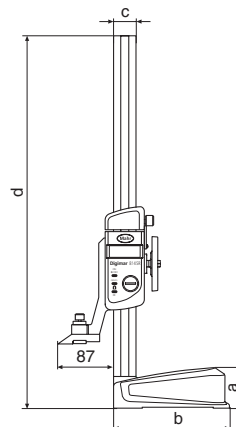

Dimensions

mm	a	b	c	d
350	62	180 x 98	35 x 15	580
600	62	180 x 98	35 x 15	835

Technical Data

Measuring range	Resolution	Error limit	Weight	Order no.
mm (inch)	mm/inch	mm/inch	kg/lbs	
350 (14")	0.01 / .0005"	0.04 / .0016"	7/ 15.43	4426100
600 (24")	0.01 / .0005"	0.05 / .0020"	8/ 17.64	4426101

Accessories

	Order no.
Measuring / Scriber Point , carbide tipped	27 ESh 4123710
Holder for test indicators	27 Sp 4123041
Battery 3V, type CR 2032	4102520
Data Connection Cable USB (2 m)	16 EXu 4102357
Data Connection Cable Opto RS232C (2 m), with SUB-D jack 9-pin	16 EXr 4102410
Data Connection Cable Digimatic (2 m), Flat plug 10-pin	16 EXd 4102411

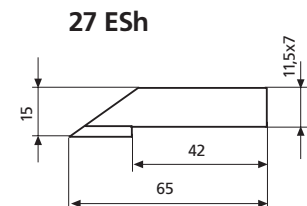
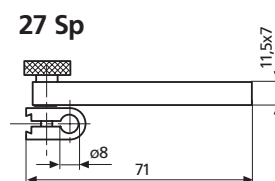

DOES EVERYTHING ROTATE AROUND PRECISION? NO PROBLEM WITH MICROMAR.



The latest information on MICROMAR products can be found on our website:
www.mahr.de, WebCode 205

► | Micrometers belong alongside calipers to the most frequently used hand measuring instruments. With their precision ground spindle, their carbide tipped measuring faces and their robust frame construction the modern micrometer from the Micromar series ensures maximum precision and a long working life. Our mechanical micrometers are extremely reliable and are easy to read due to the scales having a satin chrome finish, thus ensuring accuracy and user comfort. Our digital micrometers unite both the highly renowned mechanical precision from Mahr with most modern electronics. These digital micrometers offer simple operation with an error free reading as well as problem-free data of the determined parameters to an external evaluation instrument. Micromar 40 EW, the newest generation of waterproof digital micrometers ensures that even in the most difficult workshop conditions precise and reliable results are obtained. A speciality of Mahr is the micrometer with a dial comparator, with its built-in dial comparator, stationary anvil and constant measuring force they are particularly well suited for rapid measurements and highly precise serial measurements.

► | Micromar. Micrometers

Overview

Micromar Micrometers

3- 2

Micrometers

Micromar 40 EWR / 40 EXR / 40 EWS / 40 EWV

3- 4

With a Digital Display

Micromar 40 A / 40 SH / 40 SD / 40 AG / 40 W

3-10

With Scales

Micromar 40 F / 40 T / 40 TS

3-14

With a Dial Comparator

Micromar 40 AB / 40 AS / 40 AR / 40 AW / 40 SM

3-17

With Special Measuring Faces

Micromar 40 Z

3-20

For Gear and Thread Measurement

Accessories for Micrometers

3-22

Inside Micrometers

Micromar 44 F / 44 Cms / 44 CB / 44 CZ

3-23

Inside Micrometers with
2-Point Contact

Micromar 44 A / 44 EX / 844 A

3-29

Self-Centering Inside Micrometers

Depth Micrometers

Micromar 45 T

3-33

With a Line Scale (Vernier)

Micrometer Heads

Micromar 46 / 46H

3-34

With Digital Display or Scales (Vernier)

Micromar. Micrometer

OVERVIEW

Micromar - Design Features

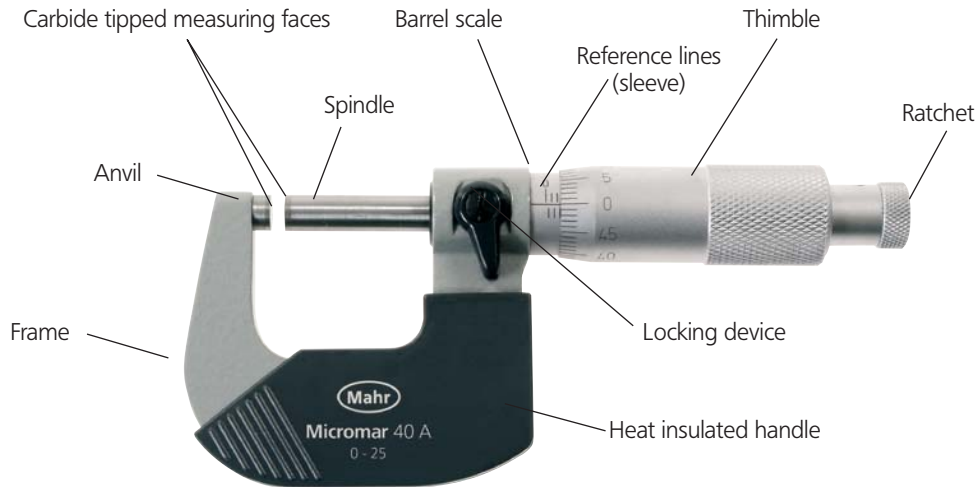

Reading example:

Micrometer with 0.01 mm-divisions



Sleeve	2.5
Thimble	0.28
Measuring result	2.78 mm

Micromar - Types of Micrometers

Mahr - Micrometers are available with the following means of indication:

a) Digital Micrometer with digital display



b) Mechanical Micrometer with scale and dial



c) Mechanical Micrometer with scale



Error limits *G* according to DIN 863-1

Measuring range mm	Error limit <i>G</i> µm	Measuring force N
0 - 25	4	5 - 10
25 - 50	4	5 - 10
50 - 75	5	5 - 10
75 - 100	5	5 - 10
100 - 125	6	5 - 10
125 - 150	6	5 - 10
150 - 175	7	5 - 10
175 - 200	7	5 - 10
200 - 225	8	5 - 10
225 - 250	8	5 - 10
250 - 275	9	5 - 10
275 - 300	9	5 - 10
300 - 325	10	5 - 10
325 - 350	10	5 - 10
350 - 375	11	5 - 10
375 - 400	11	5 - 10
400 - 425	12	5 - 10
425 - 450	12	5 - 10
450 - 475	13	5 - 10
475 - 500	13	5 - 10

Micromar - Variations

a) Micrometer



b) Micrometer for inside dimensions



c) Micrometer for depth measurement



d) Micrometer Head



Function keys of Digital Micrometers

Functions	Type
	40 EW 40 EWS 40 EWW 40 EXL 44 EX 46 EX
PR	● Enter a numerical value (Reference Setting)
mm/in	● Switch between mm/inch
0/ABS	● Set display to either 0.000 mm or .0000" for relative measurement / set to a reference or preset value (PR)
DATA	●* Data transmission



* For digital micrometers with a data output

Micromar. Digital Micrometer Micromar 40 EWR

WATERPROOF MICROMETER

► | The digital waterproof Micrometer **Micromar** 40 EWR. Even in the most difficult conditions precise and reliable results are obtained. | ◀



Waterproof measuring system, protection class **IP65** according to IEC 60529



Highly precise measuring system, Patent pending

Ratchet is integrated in the thimble, enables one handed operation



Code Initial	IP	International Protection
First Numeral	6	Dust-tight
Second Numeral	5	Protected against powerful water jets

Large display with 8.5 mm high digits

Rapid drive



Absolute-Function: Micrometer can be set in any position to 0.000 mm / .0000" without the reference to the Preset value being lost

Stainless steel, hardened spindle



Universal SPC-interface (optional). You have a choice of **MarConnect** data outputs, select either **USB**, **Digimatic** or **Mahr Opto RS232**

Sturdy satin chrome steel frame

Ergonomically formed and heat insulated steel handle

Operating buttons are made from **Ultradur**[®], which has an excellent chemical resistance



Digital Micrometer Micromar 40 EWR



Features

Functions:

RESET (Zero setting the display for Relative measurement)
 ABS (Switch between Relative and Absolute measurement) mm/inch
 Reference-Lock/Unlock
 PRESET (Reference setting)

DATA (Data transmission via connection cable)

- Immediate measurement due to the Reference system
- MarConnect data output, choose alternatively USB
OPTO RS232C
Digimatic

- High contrast Liquid Crystal Display with 8.5 mm high digits
- Hard lacquered steel frame, heat insulated
- Spindle and anvil are carbide tipped
- Spindle is made of stainless steel, hardened throughout and ground

- Ratchet is integrated in the thimble
- Rapid drive
- Supplied with: Case, battery, operating instructions and setting standard (from measuring range 25-50 mm)

Technical Data

	Measuring range	Resolution	Error limit G	Spindle thread pitch	Data output	Order no.
	mm (inch)	mm / inch	μm	mm		
40 EWR	0 - 25 (0 - 1")	0.001 / .00005"	4	0.635	—	4151721
40 EWR	0 - 25 (0 - 1")	0.001 / .00005"	4	0.635	●	4151705
40 EWR	25 - 50 (1 - 2")	0.001 / .00005"	4	0.635	●	4151706
40 EWR	50 - 75 (2 - 3")	0.001 / .00005"	5	0.635	●	4151707
40 EWR	75 - 100 (3 - 4")	0.001 / .00005"	5	0.635	●	4151708

Dimensions

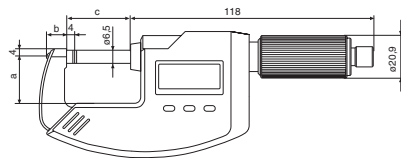

mm	a	b	c
0 - 25 mm / 0-1"	23	9.5	31.5
25 - 50 mm / 1-2"	32	11.5	57
50 - 75 mm / 2-3"	44	13.5	82
75 - 100 mm / 3-4"	57	15.5	107

Accessories

	Order no.
Battery 3V , type CR 2032	4102520
Data Connection Cable USB (2 m)	16 EXu 4102357
Data Connection Cable Opto RS232C (2 m), with SUB-D jack 9-pin	16 EXr 4102410
Data Connection Cable Digimatic (2 m), Flat plug 10-pin	16 EXd 4102411

Accessories for Data Processing see Chapter 11

Digital Micrometer Set Micromar 40 EWR

Application range	Order no.	Remarks
0 - 100 mm	4151709	Includes: custom fitted plastic case, setting standards 25 mm, 50 mm and 75 mm



Digital Micrometer Micromar 40 EXR



REFERENCE

Features

Functions:

RESET (Zero setting the display for Relative measurement)
 ABS (Switch between Relative and Absolute measurement)
 mm/inch
 Reference-Lock/Unlock
 PR (Reference setting)

- Immediate measurement due to the Reference system
- High contrast Liquid Crystal Display with 8.5 mm high digits
- Hard lacquered steel frame, heat insulated
- Spindle and anvil are carbide tipped

- Spindle is made of stainless steel, hardened throughout and ground
- Ratchet is integrated in the thimble
- Rapid drive

- Supplied with: Case, battery and operating instructions

Technical Data

Measuring range	Resolution	Error limit G	Spindle thread pitch	Order no.
40 EXR 0 - 25 (0-1")	0.001 / .00005"	4	0.635	4151601

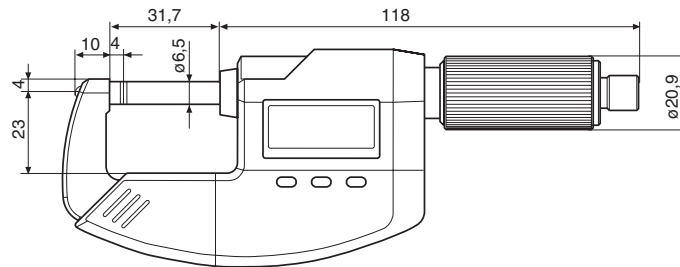

Accessories

	Order no.
Battery 3V, Type CR 2032	4102520

Digital Micrometer Micromar 40 EWS with sliding spindle

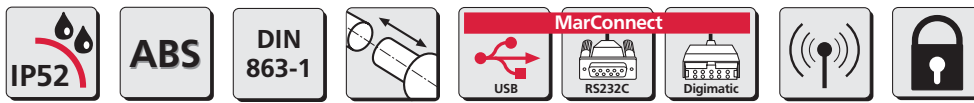

REFERENCE

Features

Functions:

RESET (Zero setting the display for Relative measurement)
 ABS (Switch between Relative and Absolute measurement)
 mm/inch
 Reference-Lock/Unlock
 PR (Reference setting)

- Immediate measurement due to the Reference system
- MarConnect data output, choose alternatively
 USB
 OPTO RS232C
 Digimatic

- High contrast Liquid Crystal Display with 8.5 mm high digits
- Hard lacquered steel frame, heat insulated
- Spindle and anvil are carbide tipped
- Spindle is made of stainless steel, hardened throughout and ground

- Ratchet is integrated in the thimble
- Rapid drive
- Supplied with:
 Case, battery and operating instructions

Technical Data

Measuring range		Resolution	Error limit G	Spindle thread pitch	Order no.
mm	(inch)	mm/inch	μm	mm	
0 - 25	(0-1")	0.001 / .00005"	4	0.635	4151724

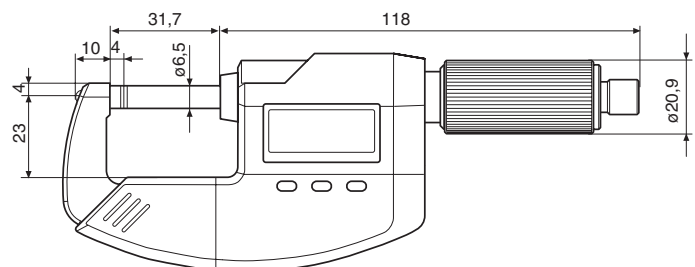

Accessories

	Order no.
Battery 3V, Type CR 2032	4102520
Data Connection Cable USB (2 m)	16 EXu 4102357
Data Connection Cable Opto RS232C (2 m), with SUB-D jack 9-pin	16 EXr 4102410
Data Connection Cable Digimatic (2 m), Flat plug 10-pin	16 EXd 4102411

Accessories for Data Processing see Dimensional Metrology catalog, Chapter 11

Universal Digital Micrometer Micromar 40 EWW with sliding spindle



REFERENCE

Features

Functions:

RESET (Zero setting the display for Relative measurement)
 ABS (Switch between Relative and Absolute measurement) mm/inch
 Reference-Lock/Unlock
 PR (Reference setting)

- Immediate measurement due to the Reference system
- MarConnect data output, choose alternatively
 USB
 OPTO RS232C
 Digimatic

- High contrast Liquid Crystal Display with 8.5 mm high digits
- Hard lacquered steel frame, heat insulated
- Mounting bore for interchangeable anvils
- Spindle is made of stainless steel, hardened throughout and ground

- Ratchet is integrated in the thimble
- Rapid drive
- Supplied with:
 Case, battery and operating instructions

Technical Data

Measuring range*	Resolution	Error limit**	Spindle thread pitch	Spindle dia.	Order no. without standard accessories	Order no. with standard accessories
mm	mm/inch	G µm	mm	mm		
0 - 25	0.001/ .00005"	4	0.635	6.5	4151722	
0 - 25	0.001/ .00005"	4	0.635	6.5		4151723

* with thread anvils the measuring range is reduced

**with flat anvils over the full length of the anvils

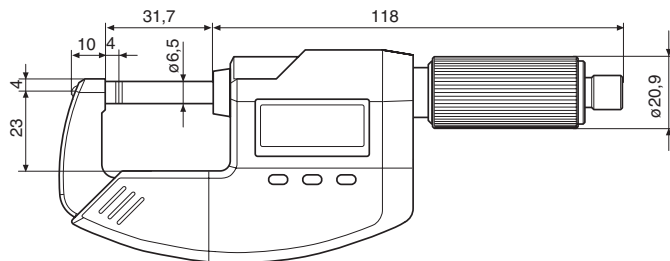

Special Accessories

	Order no.
Battery 3V, Type CR 2032	4102520
Data Connection Cable USB (2 m)	16 EXu 4102357
Data Connection Cable Opto RS232C (2 m), with SUB-D jack 9-pin	16 EXr 4102410
Data Connection Cable Digimatic (2 m), Flat plug 10-pin	16 EXd 4102411

Accessories for Data Processing see Dimensional Metrology catalog, Chapter 11

Universal Digital Micrometer Micromar 40 EWW with sliding spindle

Standard Accessories are included in the set

Catalog no.	Description	Order no.	Quantity required	
40 Efk	Flat anvils (reference)	4151771	1	
40 Efl	Flat anvils (sensitive)	4151761	1	
40 Eak	Anvils with reduced measuring faces (reference)	4151777	1	
40 Eal	Anvils with reduced measuring faces (sensitive)	4151767	1	
40 Etk	Disc type anvils (reference) d = 11.3 mm	4151772	1	
40 Etl	Disc type anvils (sensitive) d = 11.3 mm	4151762	1	
40 Erk	Anvils with spherical measuring faces	4151774	2	
40 Epk	Conical shaped anvil	4151773	2	
40 Esk	Wedge shaped anvil (blade)	4151775	2	

Special Accessories

Catalog no.	Description	Order no.	Quantity required	
40 Ekk	Wedge shaped anvil (blade) 60°	4151776	2	

Thread anvils for pitch diameters*

• Pair consists of 1 V-anvil and 1 blade anvil

* with thread anvils the measuring range is reduced by 20 mm

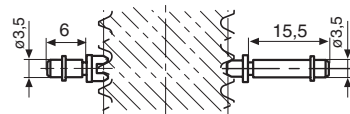

Metric thread (60°)				Whitworth thread (55°)				American UST thread (60°)			
Pitch	V-anvil	Blade		Pitch range	V-anvil	Blade		Pitch range	V-anvil	Blade	
mm	Order no.	Order no.		TPI	Order no.	Order no.		TPI	Order no.	Order no.	
0.5 - 0.7	4501000	4173700		40 - 32	4501007	4173743		40 - 32	4501018	4173815	
0.7 - 1	4501001	4173701		32 - 24	4501008	4173744		32 - 24	4501019	4173816	
1.25 - 2	4501002	4173702		24 - 18	4501009	4173745		24 - 18	4501020	4173817	
2 - 3.5	4501003	4173703		18 - 14	4501010	4173746		18 - 14	4501021	4173818	
				14 - 10	4501011	4173747		14 - 10	4501022	4173819	
				10 - 7	4501012	4173748		10 - 7	4501023	4173820	

Micrometer Micromar 40 A

DIN 863-1



Features

- Hard lacquered steel frame for measuring ranges up to 75 - 100 mm / 3 - 4"
- Spindle and anvil made of hardened steel, carbide tipped
- Scales with satin-chrome finish
- Heat insulators
- Rapid drive with integrated ratchet
- Locking device
- Supplied with: Case, setting standard (from measuring range 25-50 mm / 1-2"), operating instructions

Technical Data

Measuring range	Readings	Error limit G	Spindle thread pitch	Order no.
0 - 25 mm	0.01 mm	4 μm	0.5 mm	4134000
25 - 50 mm	0.01 mm	4 μm	0.5 mm	4134001
50 - 75 mm	0.01 mm	5 μm	0.5 mm	4134002
75 - 100 mm	0.01 mm	5 μm	0.5 mm	4134003
100 - 125 mm	0.01 mm	6 μm	0.5 mm	4134004
125 - 150 mm	0.01 mm	6 μm	0.5 mm	4134005
150 - 175 mm	0.01 mm	7 μm	0.5 mm	4134006
175 - 200 mm	0.01 mm	7 μm	0.5 mm	4134007
0 - 1"	.0001"	.00016"	.025"	4134900
1 - 2"	.0001"	.00016"	.025"	4134901
2 - 3"	.0001"	.00020"	.025"	4134902
3 - 4"	.0001"	.00020"	.025"	4134903
4 - 5"	.0001"	.00024"	.025"	4134904
5 - 6"	.0001"	.00024"	.025"	4134905
6 - 7"	.0001"	.00028"	.025"	4134906
7 - 8"	.0001"	.00028"	.025"	4134907

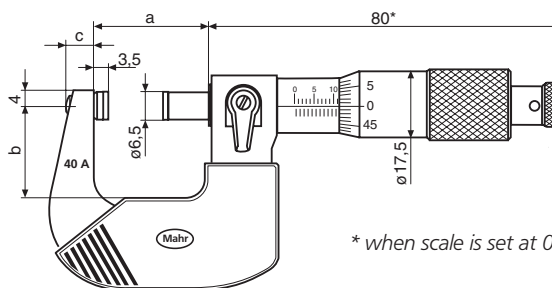

Dimensions

Measuring range mm / inch	a mm	b mm	c mm
0 - 25 mm / 0-1"	31	25.5	7
25 - 50 mm / 1-2"	56	34.5	12
50 - 75 mm / 2-3"	81	47.5	12
75 - 100 mm / 3-4"	106	58.5	13
100 - 125 mm / 4-5"	131	71.5	13
125 - 150 mm / 5-6"	156	83.5	13
150 - 175 mm / 6-7"	182	95.5	13
175 - 200 mm / 7-8"	207	108.5	13

Accessories

Stand, setting standards, etc. please refer to page 3-22

Micrometer Sets Micromar 40 SA

Application range	Order no	Remarks
0-100 mm (4 Micrometers)	4134050	Incl. wooden case, setting standards 25 mm and 75 mm
100-200 mm (4 Micrometers)	4134051	Incl. wooden case, setting standards 125 mm and 175 mm
0-4" (4 Micrometers)	4134960	Incl. wooden case, setting standards 1" and 3"
4-8" (4 Micrometers)	4134961	Incl. wooden case, setting standards 5" and 7"



Micrometer Micromar 40 SH / 40 SD with extra large thimble

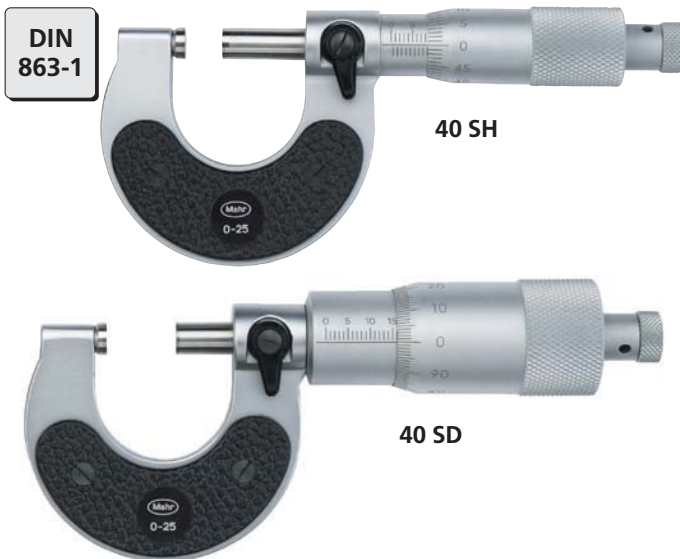

DIN 863-1

Features

- Chrome plated steel frame
- Maximum stability
- Spindle and anvil made of hardened steel, carbide tipped measuring faces
- Spindle is made of stainless steel, hardened throughout and ground
- Scales with satin-chrome finish
- Heat insulators
- Rapid drive with integrated ratchet
- Locking device
- Supplied with: Case (measuring range 0 - 100 mm)

Only 40 SD:

- Reading error is reduced due to the 1 mm measuring span per rotation of the thimble

Technical Data

	Measuring range	Readings	Error limit	Spindle thread pitch	Order no
	mm	mm	G µm	mm	
40 SH	0 - 25	0.01	4	0.5	4131000
	25 - 50	0.01	4	0.5	4131001
	50 - 75	0.01	5	0.5	4131002
	75 - 100	0.01	5	0.5	4131003
	100 - 125	0.01	6	0.5	4131004
	125 - 150	0.01	6	0.5	4131005
	150 - 175	0.01	7	0.5	4131006
	175 - 200	0.01	7	0.5	4131007
40 SD	0 - 25	0.01	4	1	4135000
	25 - 50	0.01	4	1	4135001
	50 - 75	0.01	5	1	4135002
	75 - 100	0.01	5	1	4135003

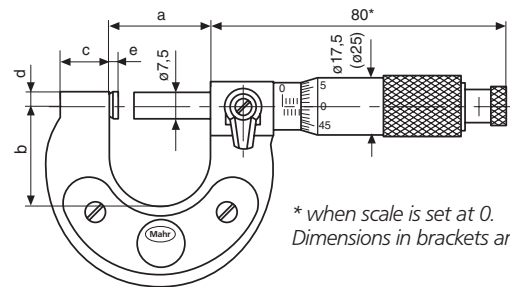

* when scale is set at 0.
Dimensions in brackets are for the 40 SD

Abmessungen

Measuring range	a	b	c	d	e
Dimensions in mm					
0 - 25	31	28	13	3.25	3
25 - 50	56	40	13	3.25	3
50 - 75	81	53	13	3.25	3
75 - 100	106	65	13	3.25	3
100 - 125	130	75.5	15	4	3.5
125 - 150	155	88	15	4	3.5
150 - 175	180	100.5	15	4	3.5
175 - 200	205	113	15	4	3.5

Accessories

Stand, setting standards, etc. please refer to page 3-22

Micrometer Sets Micromar 40 SSH

Application range	Order no.	Remarks
0-100 mm (4 Micrometers)	4133001	Incl. wooden case, setting standards 25 mm and 75 mm
100-200 mm (4 Micrometers)	4133005	Incl. wooden case, setting standards 125 mm and 175 mm



Micrometer Micromar 40 AG

**DIN
863-1**



Features

- Hard lacquered steel frame
- Spindle and anvil made of hardened steel, carbide tipped
- Scales with satin-chrome finish
- Heat insulators
- Ratchet is integrated in the thimble
- Locking device
- Supplied with:
Case, setting standard

Note:

All Micrometers with measuring ranges between 400 mm to 500 mm, the frame is made from a steel tube

Technical Data

Measuring range mm	Readings mm	Error limit G µm	Spindle thread pitch mm	Weight kg	Order no.
200 - 225	0.01	8	0.5	2.0	4134500
225 - 250	0.01	8	0.5	2.2	4134501
250 - 275	0.01	9	0.5	2.3	4134502
275 - 300	0.01	9	0.5	2.7	4134503
300 - 325	0.01	10	0.5	3.2	4134504
325 - 350	0.01	10	0.5	3.4	4134505
350 - 375	0.01	11	0.5	3.6	4134506
375 - 400	0.01	11	0.5	4.0	4134507
400 - 425	0.01	12	0.5	4.2	4134508
425 - 450	0.01	12	0.5	4.5	4134509
450 - 475	0.01	13	0.5	4.9	4134510
475 - 500	0.01	13	0.5	5.0	4134511

Dimensions

Dimensions in mm	a	b	c	d	e
200 - 225	242.5	121.5	25	5	12
225 - 250	267.5	134	25	5	12
250 - 275	292.5	146.5	25	5	12
275 - 300	317.5	159	25	5	12
300 - 325	342.5	171.5	25	5	12
325 - 350	367.5	184	25	5	12
350 - 375	392.5	196.5	25	5	12
375 - 400	417.5	209	25	5	12
400 - 425	442	223	25	5	12
425 - 450	467	236	25	5	12
450 - 475	492	248	25	5	12
475 - 500	517	259	25	5	12

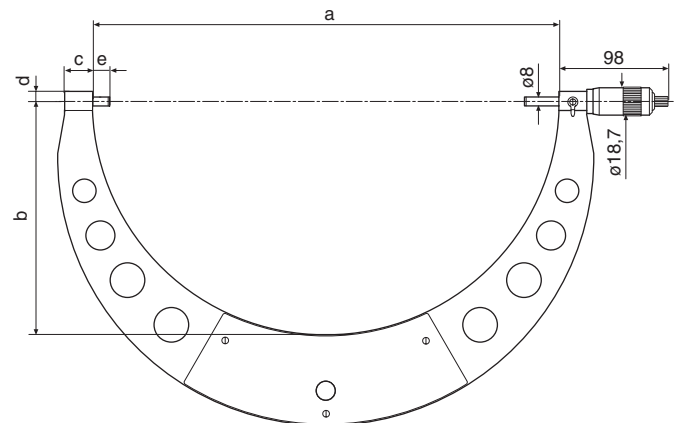

Micrometer Micromar 40 W

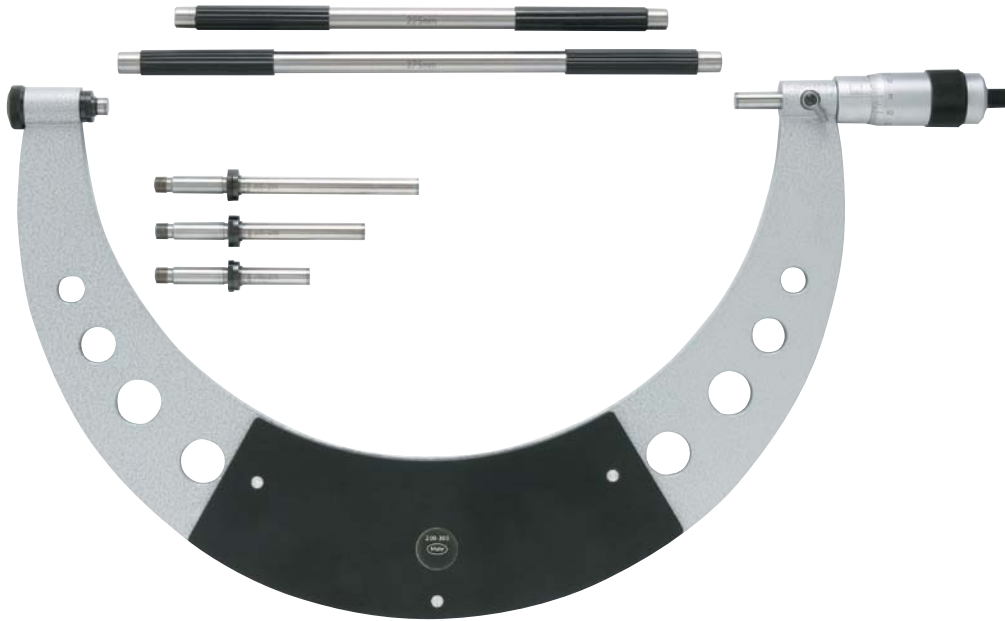

Features

- Hard lacquered steel frame
- Spindle and anvil made of hardened steel, carbide tipped
- Scales with satin-chrome finish
- Heat insulators
- Ratchet is integrated in the thimble
- Exchangeable anvils
- Locking device

- Supplied with:
Case, setting standards

Note:

All Micrometers with measuring ranges from 400 mm up to 1000 mm, the frame is made from a steel tube

Technical Data

Measuring range mm	Readings mm	Error limit G µm	Spindle thread pitch mm	Weight kg	Order no.
0 - 100	0.01	5	1	1.1	4137500
100 - 200	0.01	7	1	2.1	4137501
200 - 300	0.01	9	1	3.4	4137502
300 - 400	0.01	11	1	5.7	4137503
400 - 500	0.01	13	1	2.6	4137504
500 - 600	0.01	21	1	3.3	4137505
600 - 700	0.01	23	1	4.0	4137506
700 - 800	0.01	26	1	4.4	4137507
800 - 900	0.01	28	1	5.3	4137508
900 - 1000	0.01	30	1	6.5	4137509

Dimensions

Dimensions in mm	a	b
0 - 100	117.5	59
100 - 200	217.5	109
200 - 300	317.5	159
300 - 400	417.5	209
400 - 500	517.5	259
500 - 600	617.5	309
600 - 700	717.5	360
700 - 800	817.5	410
800 - 900	917.5	460
900 - 1000	1017.5	510

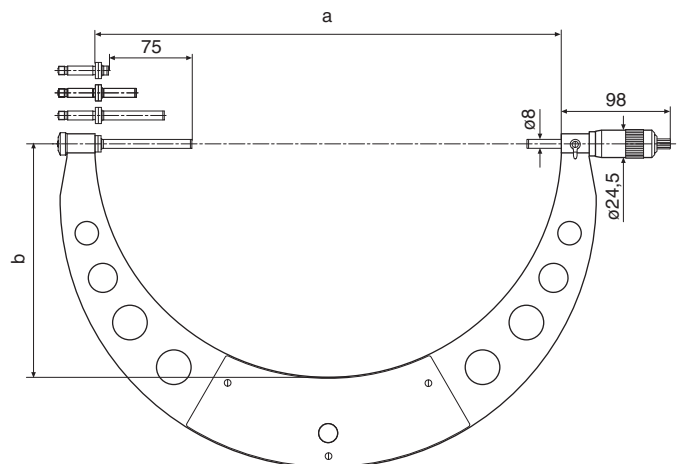

Micrometer with integrated Dial Comparator Micromar 40 F / FC

DIN
863-3



Applications

- For rapid measurements of diameters of cylindrical parts (shafts, bolts and shanks)
- Measurements of thickness and length
- Recommended for standard precision parts

Features

- Chrome plated steel frame with heat insulators
- Maximum stability
- Retraction of the movable anvil and carbide-tipped measuring faces ensures maximum wear resistance
- Longer service life due to the ceramic measuring faces (40 FC)
- Measuring spindle made of stainless steel, hardened throughout and ground, lockable
- Scales with satin-chrome finish
- Constant measuring force
- Dial Comparator is integrated in frame
- Adjustable tolerance markers (40 FC)
- Supplied with: Case

Technical Data

	Measuring range	Retraction	Measuring faces Flatness	Measuring faces Parallelism	Measuring force	Order no.	Remarks
40 F	0-25 mm	1 mm	≤0.2 μm	≤1 μm	9 N	4150000	
	25-50 mm	1 mm	≤0.2 μm	≤1 μm	9 N	4150001	
	0-1"	.04"	≤.00001"	≤.00005"	9 N	4150900	
	1-2"	.04"	≤.00001"	≤.00005"	9 N	4150901	
40 FC	0-25 mm	1 mm	≤0.2 μm	≤1 μm	9 N	4150200	Ceramic measuring faces
	25-50 mm	1 mm	≤0.2 μm	≤1 μm	9 N	4150201	

Readings	Micrometer		Dial Comparator		
	Error limit G_{me}	Spindle thread pitch	Error limit G_e (DIN 879)	Meas. range	Readings
0.01 mm .0001"	≤2 μm ≤.00008"	0.5 mm .025"	1 μm .00005"	±65 μm ±.0025"	1 μm .00005"

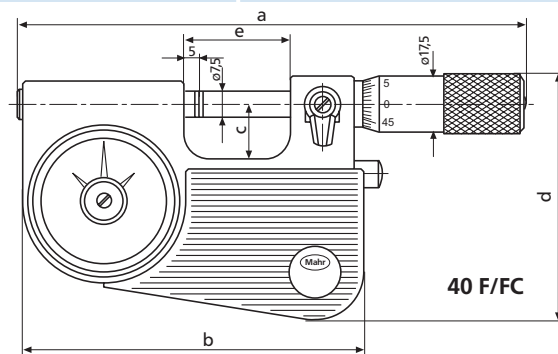

Dimensions

Dimensions in mm	a*	b	c	d	e
40 F/FC					
0-25 mm (0-1")	149	100	16	71	32
25-50 mm (1-2")	174	125	30	85	56

* in zero position

Accessories

Stand, setting standards, etc. please refer to page 3-22

Micrometer with Dial Comparator Micromar 40 T

**DIN
863-3**



Applications

- For rapid measurements of diameters of cylindrical parts (shafts, bolts and shanks)
- Measurements of thickness and length
- Recommended for standard precision parts

Features

- Rugged steel frame, heat insulated and chrome plated (up to measuring range 100 - 150 mm)
- Maximum stability
- Retraction of the movable anvil and carbide-tipped measuring faces ensures maximum wear resistance
- Measuring spindle made of stainless steel, hardened throughout and ground, lockable
- Scales with satin-chrome finish
- Constant measuring force
- Heat insulators
- Supplied with: Dial Comparator 1003, wooden case

Technical Data

Measuring range	Retraction	Measuring faces		Measuring force	Order no.*
		Flatness	Parallelism		
0 - 25 mm	1.2 mm	≤0.2 μm	≤2 μm	6.5 N	4154000
25 - 50 mm	1.2 mm	≤0.2 μm	≤2 μm	6.5 N	4154001
50 - 100 mm	1.2 mm	≤0.2 μm	≤2 μm	6.5 N	4154002
100 - 150 mm	1.2 mm	≤0.2 μm	≤2 μm	7.5 N	4154003
150 - 200 mm	1.2 mm	≤0.2 μm	≤2 μm	7.5 N	4154004

Micrometer			Dial Comparator*		
Readings	Error limit G_{me}	Spindle thread pitch	Error limit G_e (DIN 879)	Meas. range	Readings
0.01 mm	≤2 μm	0.5 mm	1 μm	±50 μm	1 μm

Dimensions

Dimensions in mm	a**	b	c	d**	e
0 - 25	27	28	4	11	8
25 - 50	52	40	4	11	8
50 - 100	76	65	5.5	30	8
100 - 150	127	87	5.5	30	8
150 - 200	177	112	5.5	30	8

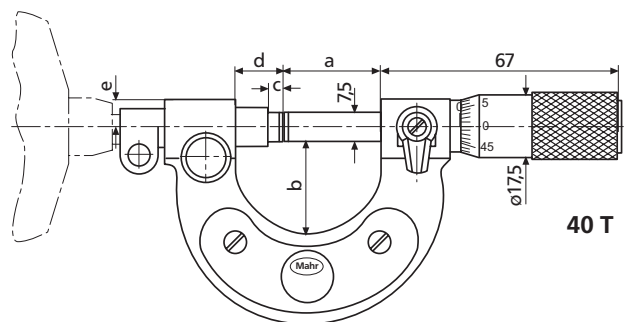

Indicating Snap Gage 840 F
see page 9-2



* Alternative indicating instruments are available on request
** in zero position

Accessories

Stand, setting standards, etc. please refer to page 3-22

Precision Bench Micrometer Micromar 40 TS

DIN 863-3



Applications

- For rapid measurements of diameters of cylindrical parts (shafts, bolts and shanks)
- Measurements of thickness and length
- Recommended for standard precision parts

Features

- Rugged steel frame, can be tilted up to 45° in relation to the sturdy base
- Retraction of the movable anvil and carbide-tipped measuring faces ensures maximum wear resistance
- Height-adjustable stop
- Constant measuring force
- Measuring spindle made of stainless steel, hardened throughout and ground, lockable
- Scales with satin-chrome finish
- Supplied with: Dial Comparator 1003

Technical Data

Measuring range	Retraction	Measuring faces Flatness Parallelism	Measuring force	Order no.*	Order no wooden case
0 - 50 mm 0 - 2"	1.2 mm .045"	≤0.2 μm ≤.00001"	6.5 N 6.5 N	4154030 4154930	4154035 4154035

* Alternative indicating instruments are available on request

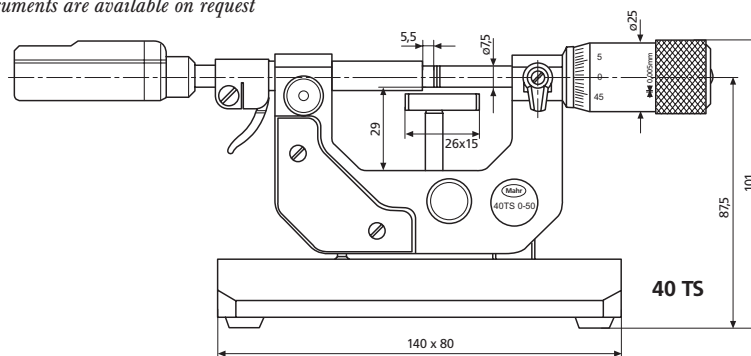

Indicating Thread Snap Gage 852 TS see page 9-17



Micrometer			Dial Comparator 1003/1003Z		
Readings	Error limit G_{me}	Spindle thread pitch	Error limit G_e (DIN 879)	Meas. range	Readings
0.01 mm .00025"	≤2 μm ≤.00008"	0.5 mm .025"	1 μm .00005"	±50 μm ±.002"	1 μm .00005"

Accessories

Stand, setting standards, etc. please refer to page 3-22

Micrometer Micromar 40 AB with reduced measuring faces



**DIN
863-3**

Features

- For measuring recesses, grooves, etc.
- Hard lacquered steel frame for measuring ranges up to 50 - 75 mm / 2 - 3"
- Spindle and anvil made of hardened steel, carbide tipped
- Scales with satin-chrome finish
- Heat insulators
- Rapid drive with integrated ratchet
- Locking device
- Supplied with: Case, setting standard (from measuring range 25 - 50 mm / 1 - 2"), operating instruction

Technical Data

Measuring range	Readings	Error limit G	Spindle thread pitch	Order no.
0 - 25 mm	0.01 mm	4 μm	0.5 mm	4134100
25 - 50 mm	0.01 mm	4 μm	0.5 mm	4134101
50 - 75 mm	0.01 mm	5 μm	0.5 mm	4134102
75 - 100 mm	0.01 mm	5 μm	0.5 mm	4134103
0 - 1"	.0001"	.00016"	.025"	4134920
1 - 2"	.0001"	.00016"	.025"	4134921
2 - 3"	.0001"	.00020"	.025"	4134922
3 - 4"	.0001"	.00020"	.025"	4134923

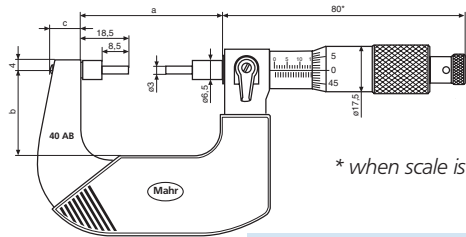

* when scale is set at 0

Dimensions in mm	a	b	c
0 - 25 mm / 0-1"	56	34.5	12
25 - 50 mm / 1-2"	81	47.5	12
50 - 75 mm / 2-3"	106	58.5	13
75 - 100 mm / 3-4"	131	71.5	13

Micrometer Micromar 40 AS with sliding spindle and measuring spades



**DIN
863-3**

Features

- For measuring narrow recesses, grooves, etc.
- Hard lacquered steel frame for measuring ranges up to 50 - 75 mm / 2 - 3"
- Spindle and anvil made of hardened steel
- Scales with satin-chrome finish
- Heat insulators
- Rapid drive with integrated ratchet
- Supplied with: Case, setting standard (from measuring range 25 - 50 mm / 1 - 2"), operating instructions

Technical Data

Measuring range	Readings	Error limit G	Spindle thread pitch	Order no.
0 - 25 mm	0.01 mm	4 μm	0.5 mm	4134200
25 - 50 mm	0.01 mm	4 μm	0.5 mm	4134201
50 - 75 mm	0.01 mm	5 μm	0.5 mm	4134202
75 - 100 mm	0.01 mm	5 μm	0.5 mm	4134203
0 - 1"	.0001"	.00016"	.025"	4134930
1 - 2"	.0001"	.00016"	.025"	4134931
2 - 3"	.0001"	.00020"	.025"	4134932
3 - 4"	.0001"	.00020"	.025"	4134933

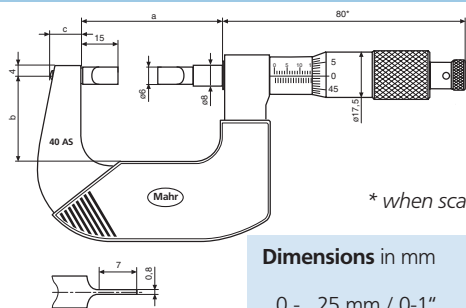

* when scale is set at 0

Dimensions in mm	a	b	c
0 - 25 mm / 0-1"	56	34.5	12
25 - 50 mm / 1-2"	81	47.5	12
50 - 75 mm / 2-3"	106	58.5	13
75 - 100 mm / 3-4"	131	71.5	13

Micrometer Micromar 40 AR with spherical anvils



DIN
863-3

Features

- For measuring the wall thickness of a pipe, etc.
- Hard lacquered steel frame
- Spindle and anvil made of hardened steel, carbide tipped
- Scales with satin-chrome finish
- Heat insulators
- Rapid drive with integrated ratchet
- Locking device
- Supplied with: Case, setting standard (measuring range for 25 - 50 mm / 1 - 2"), operating instructions

Technical Data

Measuring range	Readings	Error limit G	Spindle thread pitch	Order no.
0 - 25 mm	0.01 mm	4 μm	0.5 mm	4134250
25 - 50 mm	0.01 mm	4 μm	0.5 mm	4134251
0 - 1"	.0001"	.00016"	.025"	4134940
1 - 2"	.0001"	.00016"	.025"	4134941

Dimensions in mm	a	b	c
0 - 25 mm / 0-1"	31	25,5	7
25 - 50 mm / 1-2"	56	34,5	12

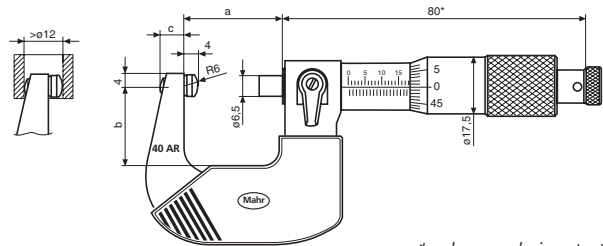

* when scale is set at 0

Micrometer Micromar 40 AW with sliding spindle and disc-type anvils



Features

- For measuring soft materials such as felt, rubber, cardboard, etc.
- Hard lacquered steel frame
- Spindle and anvil made of hardened steel
- Scales with satin-chrome finish
- Heat insulators
- Rapid drive with integrated ratchet
- Supplied with: Case, operating instructions

Technical Data

Measuring range	Readings	Error limit G	Parallelism	Flatness	Spindle thread pitch	Order no
0 - 25 mm	0.01 mm	8 μm	5 μm	2 μm	0.5 mm	4134300
0 - 1"	.0001"	.0003"	.0002"	.001"	.025"	4134950

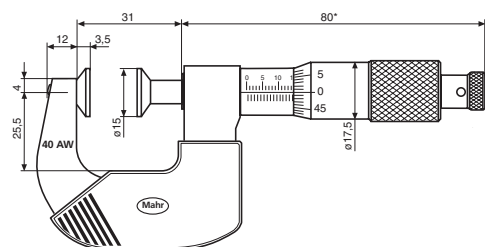

* when scale is set at 0

Precision Micrometer Micromar 40 SM with disc-type anvils

**DIN
863-3**



Features

- Chrome plated steel frame
- Maximum stability
- Spindle is hardened through-out and ground
- Disc-type anvils are hardened and lapped
- Scale have a satin chrome finish
- Heat insulators
- Rapid drive with integrated ratchet
- Locking device
- Supplied with: Case (measuring range 0 - 95 mm)

Applications

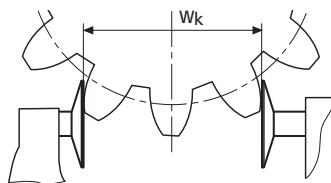

- For measurements of
- Tooth spans W_k as of module 0.8 as indirect determination of tooth thickness on spur gears with straight and helical teeth
 - Shoulders on shafts
 - Undercut dimensions
 - Registers
 - Soft materials such as rubber, cardboard, felt, etc.

Technical Data

Measuring range mm	Readings mm	Error limit G μm	Spindle thread pitch mm	Measuring faces		Order no.
				Flatness μm	Parallelism μm	
0 - 20	0.01	4	0.5	≤ 0.6	≤ 4	4145000
20 - 45	0.01	4	0.5	≤ 0.6	≤ 4	4145001
45 - 70	0.01	5	0.5	≤ 0.6	≤ 4	4145002
70 - 95	0.01	5	0.5	≤ 0.6	≤ 4	4145003
95 - 120	0.01	6	0.5	≤ 0.6	≤ 5	4145004
120 - 145	0.01	6	0.5	≤ 0.6	≤ 5	4145005
145 - 170	0.01	7	0.5	≤ 0.6	≤ 5	4145006
170 - 195	0.01	7	0.5	≤ 0.6	≤ 5	4145007

Dimensions

Dimensions in mm	a	b	c	d	e	f
0 - 20	31	28	13	3.25	4.5	25
20 - 45	56	40	13	3.25	4.5	25
45 - 70	81	53	13	3.25	4.5	25
70 - 95	106	65	13	3.25	4.5	25
95 - 120	130	75.5	15	4	4.5	30
120 - 145	155	88	15	4	4.5	30
145 - 170	180	100.5	15	4	4.5	30
170 - 195	205	113	15	4	4.5	30

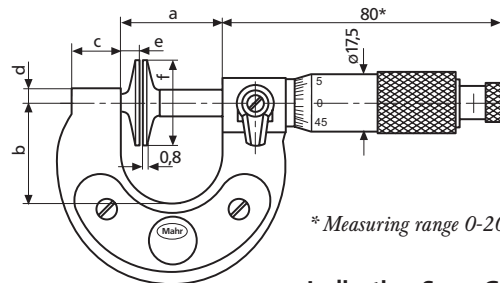

Indicating Snap Gage 840 FM
see page 9-10

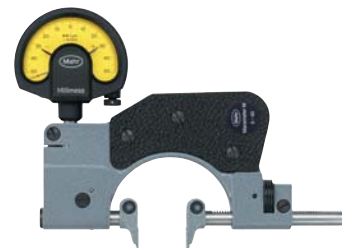

Accessories

Stand, setting standards, etc. please refer to page 3-22

Thread Micrometer Micromar 40 Z

DIN 863-3



Features

- For measuring pitch, root and outside diameters
- Rugged steel frame, heat insulated
- Spindle is hardened throughout, ground and is also provided with a locking device
- Adjustable anvil
- Spindle and anvil both have a mounting bore to accommodate interchangeable anvils
- Flat end surface of the anvil shank rests on a hardened steel ball which is at the bottom of the mounting bore device
- Scales have a satin-chrome finish

Technical Data

Readings	0.01 mm
Mounting bores for anvils	3.5 mm
Spindle thread pitch	0.5 mm
Thimble dia.	17.5 mm
Accuracy	DIN 863

Measuring range mm	Error limit G_{me}	Order no.	Order no. wooden case
0 - 25*	4 μ m	4170000	4170010
25 - 50	4 μ m	4170001	4170011
50 - 75	5 μ m	4170002	4170012
75 - 100	5 μ m	4170003	4170013
100 - 125	6 μ m	4170004	4170014
125 - 150	6 μ m	4170005	4170015
150 - 175	7 μ m	4170006	4170016
175 - 200	7 μ m	4170007	4170017

* Setting only with Thread Setting Plug Gages 715 E, when the interchangeable anvils span over several leads

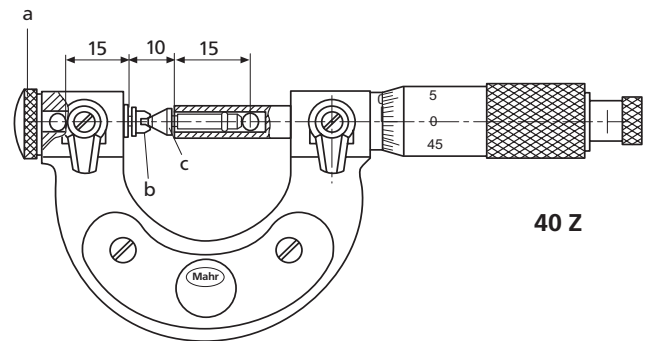

a = Regulating range ± 0.5 mm
 b = V-anvil
 c = Tapered anvil

Indicating Thread Snap Gage 852 see page 9-16



Accessories

Setting Standards 43 Z

For setting Thread Micrometers 40 Z. With point on one side and a V-groove on the other, both match the pitch angle of thread to be inspected. One setting standard is sufficient for two adjacent frame sizes.

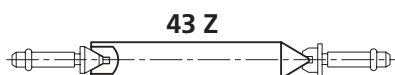

Length mm	Accuracy $\pm \mu$ m	Thread angle 60° Order no.	Thread angle 55° Order no.
25	4	4175000	4175100
50	4.5	4175001	4175101
75	4.5	4175002	4175102
100	4.5	4175003	4175103
125	5	4175004	4175104
150	5	4175005	4175105
175	5	4175006	4175106
200	5.5	4175630	4175636

Interchangeable Anvils for Thread Micrometer Micromar 40 Z

For pitch, root and outside diameters. Hardened, wear-resistant special steel. With cylindrical mounting shank and retainer ring which ensures locking while permitting rotation in bore of spindle and anvil.

For pitch diameters

Pair consists of V-anvil and tapered anvil. For pitch range 0.2 - 0.45 mm V-anvil covers 3 thread leads, set with a Thread Setting Plug Gage 715 E, as opposed to Setting Standards 43 Z for other applications.

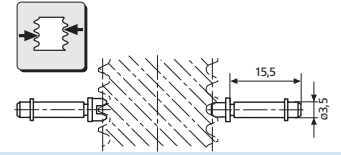

Metric thread (60°)			Whitworth thread (55°)			American UST thread (60°)		
Pitch	V-anvil	Tapered anvil	Pitch range	V-anvil	Tapered anvil	Pitch range	V-anvil	Tapered anvil
mm	Order no.	Order no.	TPI	Order no.	Order no.	TPI	Order no.	Order no.
0.2	4173007	4173407	40 - 32	4173043	4173443	60 - 48	4173113	4173513
0.25	4173008	4173408	32 - 24	4173044	4173444	48 - 40	4173114	4173514
0.3	4173009	4173409	24 - 18	4173045	4173445	40 - 32	4173115	4173515
0.35	4173010	4173410	18 - 14	4173046	4173446	32 - 24	4173116	4173516
0.4	4173011	4173411	14 - 10	4173047	4173447	24 - 18	4173117	4173517
0.45	4173012	4173412	10 - 7	4173048	4173448	18 - 14	4173118	4173518
0.5 - 0.7	4173000	4173400	7 - 4.5	4173049	4173449	14 - 10	4173119	4173519
0.7 - 1	4173001	4173401	4.5 - 3	4173050	4173450	10 - 7	4173120	4173520
1.25 - 2	4173002	4173402	3 - 2.5	4179408	4179409	7 - 4.5	4173121	4173521
2 - 3.5	4173003	4173403				4.5 - 3	4173122	4173522
3.5 - 5	4173004	4173404						
5 - 7	4173005	4173405						
7 - 9	4173006	4173406						

For pitch diameters

Pair consists of V-anvil and tapered anvil. Shank length 15,5 mm

For root diameters

Pair consists of V-anvil and pointed anvil. Each pitch requires a separate V-anvil. The pointed anvil can be used for several pitches.

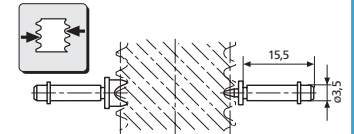

Trapezoid threads according to DIN 103			Metric thread (60°)			Whitworth thread (55°) American UST thread (60°)		
Pitch	V-anvil	Tapered anvil	Pitch	V-anvil	Pointed anvil	Pitch range	V-anvil	Pointed anvil
mm	Order no.	Order no.	mm	Order no.	Order no.	TPI	Order no.	Order no.
1	4173250	4173650	0.5	4173213		40	4173331	
1.5	4173251	4173651	0.6	4173214		36	4173321	4173334
2	4173252	4173652	0.7	4173215		32	4173332	
3	4173253	4173653	0.75	4173216	4173220	28	4173333	
4	4173254	4173654	0.8	4173217		26	4173335	
5	4173255	4173655	0.9	4173218		24	4173336	
6	4173256	4173656	1	4173219		22	4173337	4173341
7	4173257	4173657	1.25	4173221		20	4173338	
8	4173258	4173658	1.5	4173222	4173224	19	4173339	
9	4173259	4173659	1.75	4173223		18	4173340	
10	4173260	4173660	2	4173225		16	4173342	4173344
			2.5	4173226	4173228	14	4173343	
			3	4173227		12	4173345	4173348
			3.5	4173229		11	4173346	
			4	4173230	4173232	10	4173347	
			4.5	4173231		9	4173349	4173452
			5	4173233		8	4173350	
			5.5	4173234	4173236	7	4173451	
			6	4173235		6	4173453	
			7	4173237		5	4173454	4173456
			8	4173238	4173240	4.5	4173455	
			9	4173239		4	4173457	
						3.5	4173458	4173461
						3.25	4173459	
						3	4173460	

For outside diameter

Pair of Flat Anvils 40 Za
with flat measuring faces

Made of hardened steel
Order no. 4173210
 Carbide tipped
Order no. 4511190

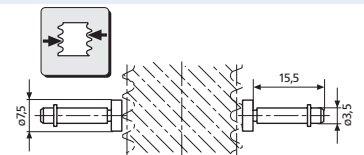

Accessories for Micromar Micrometers



41 H

Stand 41 H

- For mounting a micrometer
- Enables the user to use both hands to operate the micrometer and / or to insert a work piece
- Sturdy, heavy-duty base, hammer-dimple enamel finish
- Jaw width 3.5 - 15 mm
- Clamping jaws are rubber lined to protect micrometer, the clamping jaws can be tilted
- Both the clamping jaws and hinge are fixed in place with one screw

Dimensions (D x W x H)

130 x 100 x 90 mm

Order no.

4158000

Ball shaped Anvil Attachment 40 k

- For measuring the thickness, for example: of pipe walls
- Slips over every anvil or the spindle with a dia. 7.5 mm
- Carbide ball, Ball dia. 5 ± 0.002 mm

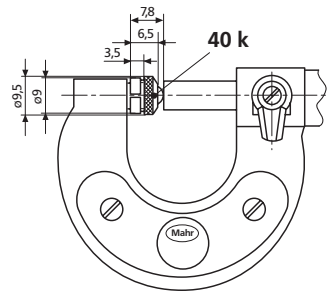

Order no. 4130099

Setting Standards 43 A

- For testing the basic setting of a micrometer
- Heat insulated handle
- Manufacturing tolerance js 2



Thread Pin Gage 426 M in holder

- For determining the pitch diameter of external threads according to the three wire method
- Slips over every anvil or the spindle
- Pin gages are hardened and lapped

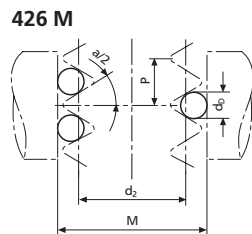

Length mm

Order no.

Length inch

Order no.

25	4159400	1"	4159940
50	4159401	2"	4159941
75	4159402	3"	4159942
100	4159403	4"	4159943
125	4159404	5"	4159944
150	4159405	6"	4159945
175	4159406	7"	4159946

Wooden Cases for Micrometer

For measuring ranges over 100 mm the following wooden cases are available:

Pin gage dia.	Manufacturing tol.	Mounting hole
0.17 - 5.05 mm	$\pm 0.5 \mu\text{m}$	dia. 6.5 mm / 7.5 mm

Order no. and further details see page 13-13

	40 SH	40 SM	Order no.
Meas. range mm	100-125	95-120	4130064
	125-150	120-145	4130065
	150-175	145-170	4130066
	175-200	170-195	4130067

Inside Micrometer Micromar 44 F

DIN 863-4



Features

- Rigid, lightweight tubular construction
- Spindle is hardened throughout and ground
- Measuring faces spherically lapped, one measuring face adjustable
- Scales with satin-chrome finish
- From measuring range 100-125 mm with heat insulators and a locking device
- Supplied with: Case

Technical Data

Measuring range mm	Readings mm	Error limit G µm	Spindle thread pitch mm	Order no.
30 - 40	0.01	4	0.5	4163000
40 - 50	0.01	4	0.5	4163001
50 - 70	0.01	5	0.5	4163002
70 - 100	0.01	5	0.5	4163003
100 - 125	0.01	6	0.5	4163004
125 - 150	0.01	6	0.5	4163005
150 - 175	0.01	7	0.5	4163006
175 - 200	0.01	7	0.5	4163007

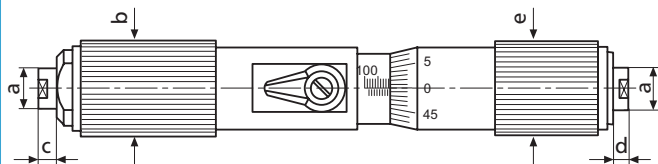

Dimensions

Meas. range in mm	a	b	c	d	e
30 - 40	ø7	ø12.5	2	4	ø12.6
40 - 50	ø7	ø12.5	2.5	4.5	ø12.6
50 - 70	ø7	ø13.5	2.5	4.5	ø13.6
70 - 100	ø7	ø13.5	4.5	4.5	ø14.0
100 - 125	ø8	ø20	4.5	4.5	ø20
125 - 150	ø8	ø20	8	8	ø20
150 - 175	ø8	ø20	8	8	ø20
175 - 200	ø8	ø20	8	8	ø20

Accessories

Ring Gage 355 E for testing the basic setting Page 13-14

Special wear resistant steel, hardened and lapped
 Dimensions according to DIN 2250 C
 Manufacturing tolerance in accordance to DIN 2250
 Uncertainty of the engraved actual dimension 1/2 IT1



Inside Micrometer Micromar 44 Cms Set

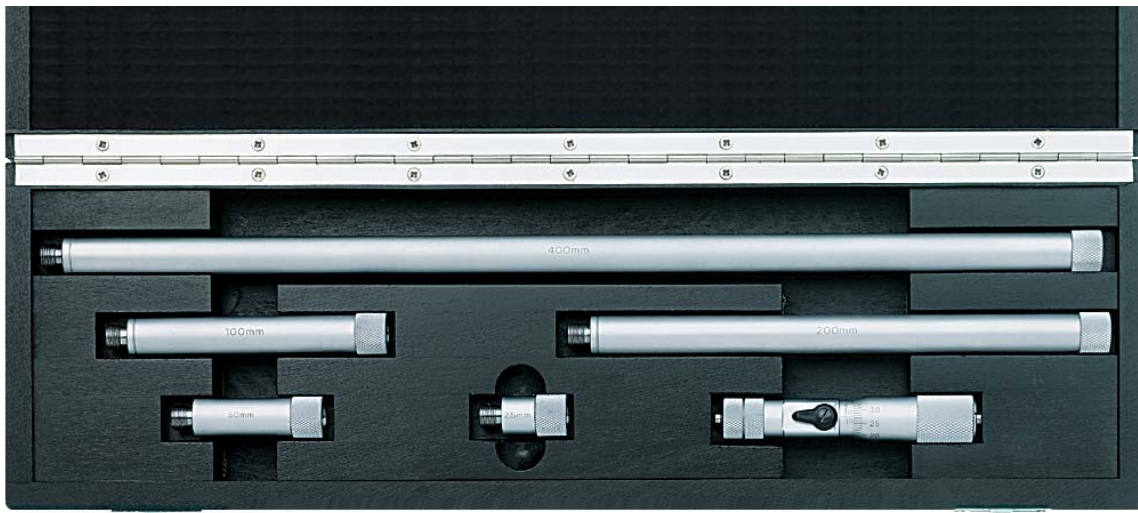

Features

- Rigid, lightweight tubular construction
 - Spindle is hardened throughout and ground
 - Locking lever
 - Scales with satin-chrome finish
 - Carbide tipped spherical measuring faces
 - Interchangeable extensions 44 Cv with cylindrical gage rods that are spring-mounted in protective sleeves; for the extension of the measuring range
 - Protection sleeves have a satin chrome finish
- Span of error**
Basic unit 5 μm
- Basic unit in combination with any of the extensions
 $4 \mu\text{m} + 10 \times 10^{-6} \times l$
 (l = length of the combination in mm)
- Supplied with: Case

Technical Data

Catalog no.	Measuring range		Measuring head 44 Cm		Extensions 44 Cv length in mm	Order no.
	mm		Readings	Spindle thread pitch		
	mm		mm	mm	mm	
44 Cms1	100	- 150			25	4168020
44 Cms2	100	- 300			25 / 50 / 100	4168021
44 Cms3	100	- 500	0.01	0.5	25 / 50 / 100 / 200	4168022
44 Cms4	100	- 900*			25 / 50 / 100 / 200 / 400	4168023

* up to 2500 mm can be achieved with 2 extensions: 44 Cv 800 mm

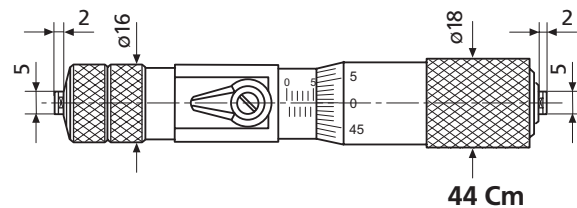

Accessories

Inside Micrometers, ring gages, etc. please refer to page 3-28

Inside Micrometer Micromar 44 CB with reduced measuring faces

DIN
863-4



Features

- Basic Instrument consists of: Measuring head 44 CBm and End piece CBv
 - Measuring faces have a smaller diameter for measuring grooves
 - Rigid, lightweight tubular construction
 - Spindle is hardened throughout and ground
 - Locking lever
 - Carbide tipped spherical measuring faces
 - Interchangeable extensions 44 Cv with cylindrical gage rods that are spring-mounted in protective sleeves; for the extension of the measuring range (Accessories)
 - Protection sleeves have a satin chrome finish
- Span of error**
Basic unit 6 μm
Basic unit in combination with any of the extensions
 $4 \mu\text{m} + 10 \times 10^{-6} \times l$
(l = length of the combination in mm)
- Supplied with: Case

Technical Data

Measuring range (Measuring head 44 CBm and End piece CBv) mm	Measuring head 44 CBm		Order no.
	Readings mm	Spindle thread pitch mm	
150 - 175	0.01	0.5	4167922
175 - 200			4167906
250 - 275			4167912
275 - 300			4167921

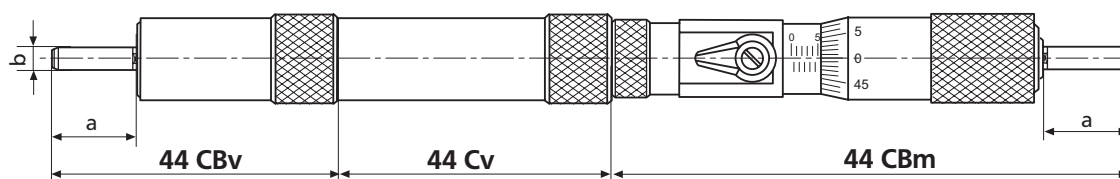

Accessories

Individual Extensions 44 Cv

Length mm	Order no.	Length mm	Order no.
25	4167030	200	4167033
50	4167031	400	4167034
100	4167032	800	4167035

Case, wooden boxes, etc. please refer to page 3-28

Dimensions

Meas. range in mm	a	b
150 - 175	10	dia. 5
175 - 200	20	dia. 5
250 - 275	40	dia. 5
275 - 300	50	dia. 5

Inside Thread Micrometer Micromar 44 CZ

DIN
863-4



Features

- Basic Instrument consists of: Measuring head and End piece
 - Measuring head and End piece with mounting bore for interchangeable anvils
 - Rigid, lightweight tubular construction
 - Spindle is hardened throughout and ground
 - Locking lever
 - Scales with satin-chrome finish
 - Carbide tipped spherical measuring faces
 - Interchangeable extensions 44 Cv with cylindrical gage rods that are spring-mounted in protective sleeves; for the extension of the measuring range (Accessories)
 - Protection sleeves have a satin chrome finish
- Span of error**
Basic unit 6 μm
- Basic unit in combination with any of the extensions
 $4 \mu\text{m} + 10 \times 10^{-6} \times l$
 (l = length of the combination in mm)
- Supplied with: Case

Technical Data

Measuring range (Measuring head 44 CZm and End piece CZe) mm	Measuring head 44 CZm		Order no.
	Readings	Spindle thread pitch	
200 - 225	mm 0.01	mm 0.5	4168030

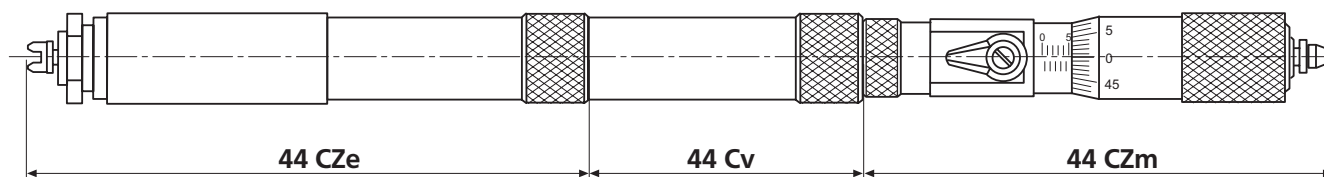

Accessories

Individual Extensions 44 Cv

Length mm	Order no.	Length mm	Order no.
25	4167030	200	4167033
50	4167031	400	4167034
100	4167032	800	4167035

Case, wooden boxes, etc. please refer to page 3-28

Inchangeable Anvils for Inside Thread Micrometer Micromar 44 CZm

For pitch, root and outside diameters. Hardened, wear-resistant special steel. With cylindrical mounting shank and retainer ring which ensures locking while permitting rotation in bore of spindle and anvil.

For pitch diameters

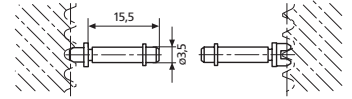

Metric thread (60°)			Whitworth thread (55°)			American UST thread (60°)		
Pitch	V-anvil	Tapered anvil	Pitch range	V-anvil	Tapered anvil	Pitch range	V-anvil	Tapered anvil
mm	Order no.	Order no.	TPI	Order no.	Order no.	TPI	Order no.	Order no.
0.5 - 0.7	4179400	4173400	40 - 32	4179043	4173443	40 - 32	4179115	4173515
0.7 - 1	4179401	4173401	32 - 24	4179044	4173444	32 - 24	4179116	4173516
1.25 - 2	4179402	4173402	24 - 18	4179045	4173445	24 - 18	4179117	4173517
2 - 3.5	4179403	4173403	18 - 14	4179046	4173446	18 - 14	4179118	4173518
3.5 - 5	4179404	4173404	14 - 10	4179047	4173447	14 - 10	4179119	4173519
5 - 7	4179405	4173405	10 - 7	4179048	4173448	10 - 7	4179120	4173520
7 - 9	4179406	4173406	7 - 4.5	4179049	4173449	7 - 4.5	4179121	4173521
			4.5 - 3	4179050	4173450	4.5 - 3	4179122	4173522
			3 - 2.5	4179407	4179409			

For pitch diameters

Pair consists of V-anvil and tapered anvil. Shank length 15.5 mm

For outside diameters

Pair consists of V-anvil and pointed anvil. Each pitch requires a separate V-anvil. The pointed anvil can be used for several pitches.

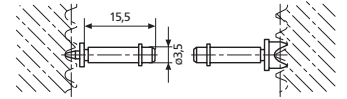

Trapezoid threads according to DIN 103			Metric thread (60°)			Whitworth thread (55°) American UST thread (60°)		
Pitch	V-anvil	Pointed anvil	Pitch	V-anvil	Pointed	Pitch range	V-anvil	Pointed anvil
mm	Order no.	Order no.	mm	Order no.	Order no.	TPI	Order no.	Order no.
1	4179950	4173650	0.5	4179513		40	4179730	
1.5	4179951	4173651	0.6	4179514		36	4179731	4173334
2	4179952	4173652	0.7	4179515		32	4179732	
3	4179953	4173653	0.75	4179516	4173220	28	4179733	
4	4179954	4173654	0.8	4179517		26	4179735	
5	4179955	4173655	0.9	4179518		24	4179736	
6	4179956	4173656	1	4179519		22	4179737	4173341
7	4179957	4173657	1.25	4173951		20	4179738	
8	4179958	4173658	1.5	4179522	4173224	19	4179739	
9	4179959	4173659	1.75	4179523		18	4179740	
10	4179960	4173660	2	4179525		16	4179742	4173344
12	4179961	4173661	2.5	4179526	4173228	14	4179743	
14	4179962	4173662	3	4179527		12	4179745	4173348
16	4179963	4173663	3.5	4179529		11	4179746	
18	4179964	4173664	4	4179530	4173232	10	4179747	
20	4179965	4173665	4.5	4179531		9	4179749	4173452
			5	4179533		8	4179750	
			5.5	4179534	4173236	7	4179751	
			6	4179535		6	4179753	
						5	4179754	4173456
						4.5	4179755	
						4	4179757	
						3.5	4179758	4173461
						3.25	4179759	
						3	4179760	

Accessories for Micromar 44 Cms / 44 CB / 44 CZ

Individual Extensions 44 Cv

Length a mm	dia. b mm	Order no.
25	15	4167030
50	15	4167031
100	15	4167032
200	15	4167033
400	15	4167034
800	22	4167035

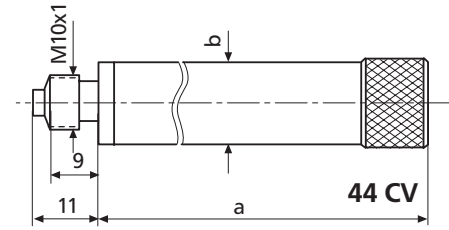

Inside Micrometer 44 Cm

Measuring range mm	Reading mm	Spindle thread pitch mm	Order no.
100 - 125	0.01	0.5	4168001

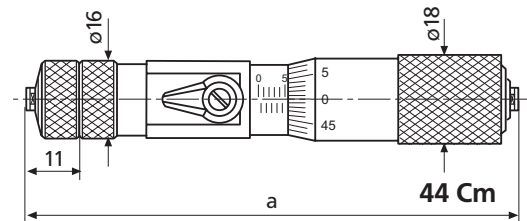

Ring Gage 355 E

Ring Gage 355 E for testing the basic setting see page 13-14

Special wear resistant steel,
hardened and lapped
Dimensions according to DIN 2250 C
Manufacturing tolerance in accordance to DIN 2250
Uncertainty of the engraved actual dimension 1/2 IT1



Order no.

Case for Inside Micrometer 44 Cm and extension sets Cvs1 or Cvs2 **4168015**

Wooden case for 2 extensions 44Cv 800 mm **4168016**

Self-Centering Inside Micrometer Micromar 44 A

**DIN
863-4**



Applications

- For measuring:
- through holes
 - blind holes
 - centering shoulders

Features

- Scales with satin-chrome finish
- Spindle is hardened through-out and ground
- Rapid drive with integrated ratchet
- Self-centering measuring head consists of 3 laterally positioned anvils, each are offset at intervals of 120°
- Anvils from 12.5 mm are carbide tipped
- From 12.5 mm the anvils can be used to measure to the bottom of a bore
- From 40 mm all measuring heads are made from aluminum to reduce weight
- Supplied with:
Case and operating instructions

Technical Data

Measuring range mm	Measuring depth mm	Readings mm	Error limit G* µm	Order no.
6 - 8	64 / (139**)	0.005	4	4190000
8 - 10	64 / (139**)	0.005	4	4190001
10 - 12.5	64 / (139**)	0.005	4	4190002
12.5 - 16	65 / (140**)	0.005	4	4190003
16 - 20	65 / (140**)	0.005	4	4190004
20 - 25	70 / (220**)	0.005	4	4190005
25 - 30	70 / (220**)	0.005	4	4190006
30 - 35	71 / (221**)	0.005	4	4190007
35 - 40	71 / (221**)	0.005	4	4190008
40 - 50	79 / (229**)	0.005	4	4190009
50 - 60	79 / (229**)	0.005	5	4190010
60 - 70	79 / (229**)	0.005	5	4190011
70 - 85	97 / (247**)	0.005	5	4190012
85 - 100	97 / (247**)	0.005	5	4190013
100 - 125	132 / (282**)	0.005	6	4190014
125 - 150	132 / (282**)	0.005	6	4190015
150 - 175	132 / (282**)	0.005	7	4190016
175 - 200	132 / (282**)	0.005	7	4190017

* Over the full length of the anvils

** With the extension 44 Av

Accessories

Measuring heads, ring gages, etc. please refer to page 3-32

Self-Centering Inside Micrometer Sets 44 AS

Measuring range mm	Number of Micrometers	Ring gages ø mm	Order no.
6 - 12.5	3	8 / 10	4190050
12.5 - 25	3	16 / 20	4190051
25 - 50	4	30 / 40	4190052
50 - 100	4	60 / 85	4190053

- Supplied with:
Case and ring gage (includes a traceable calibration certificate for the ring gages)



Digital Self-Centering Inside Micrometer Micromar 44 EX



Applications

- For measuring:
 - through holes
 - blind holes
 - centering shoulders

Features

Functions:

- 0 (Setting the display to zero for Relative measurement)
- ABS (Switching between Relative and Absolute measurement)
- mm/inch
- PR (Reference setting)

- Basic Instrument consists of:
 - Basic Unit 44 EXg and
 - Measuring Head 44 Ak

- Threaded connection for changing the measuring heads

- Self-Centering measuring head consists of 3 laterally positioned anvils, each are offset at intervals of 120°

- Anvils from 12.5 mm are carbide tipped

- From 12.5 mm the anvils can be used to measure to the bottom of a bore

- From 40 mm all measuring heads are made from aluminum to reduce weight

- Supplied with:
 - Case, battery and operating instructions

Technical Data

Measuring range		Measuring depth mm	Readings mm/inch	Error limit G* µm	Order no.
mm	(inch)				
6 - 8	(.25 - .3125")	64 / (139**)	0.001 / .00005"	4	4191000
8 - 10	(.3125 - .4")	64 / (139**)	0.001 / .00005"	4	4191001
10 - 12.5	(.4 - .5")	64 / (139**)	0.001 / .00005"	4	4191002
12.5 - 16	(.5 - .625")	65 / (140**)	0.001 / .00005"	4	4191003
16 - 20	(.625 - .775")	65 / (140**)	0.001 / .00005"	4	4191004
20 - 25	(.775 - 1")	70 / (220**)	0.001 / .00005"	4	4191005
25 - 30	(1" - 1.2")	70 / (220**)	0.001 / .00005"	4	4191006
30 - 35	(1.2 - 1.4")	71 / (221**)	0.001 / .00005"	4	4191007
35 - 40	(1.4 - 1.6")	71 / (221**)	0.001 / .00005"	4	4191008
40 - 50	(1.6" - 2")	79 / (229**)	0.001 / .00005"	4	4191009
50 - 60	(2" - 2.35")	79 / (229**)	0.001 / .00005"	5	4191010
60 - 70	(2.35 - 2.75")	79 / (229**)	0.001 / .00005"	5	4191011
70 - 85	(2.75 - 3.35")	97 / (247**)	0.001 / .00005"	5	4191012
85 - 100	(3.35 - 4")	97 / (247**)	0.001 / .00005"	5	4191013
100 - 125	(4 - 4.9")	132 / (282**)	0.001 / .00005"	6	4191014
125 - 150	(4.9 - 5.9")	132 / (282**)	0.001 / .00005"	6	4191015
150 - 175	(5.9 - 6.9")	132 / (282**)	0.001 / .00005"	7	4191016
175 - 200	(6.9 - 7.9")	132 / (282**)	0.001 / .00005"	7	4191017

* Over the full length of the anvils

** With the extension 44 Av

Accessories

Measuring heads, ring gages, etc. please refer to page 3-32

Digital Self-Centering Inside Micrometer Sets Micromar 44 EXS

Measuring range		Number of measuring heads 44 Ak	Ring gages dia. mm	Order no.*
mm	(inch)			
6 - 12.5	(.25 - .5")	3	8 / 10	4191050
12.5 - 25	(.5 - 1")	3	16 / 20	4191051
25 - 50	(1 - 2")	4	30 / 40	4191052
50 - 100	(2 - 4")	4	60 / 85	4191053

- Supplied with:
 - 1 Basic Unit 44 EXg, Measuring Heads 44 Ak, case and ring gages (includes a traceable calibration certificate for the ring gages)



Self-Centering Measuring Pistol Micromar 844 A



Applications

- For measuring:
- through holes
 - blind holes
 - centering shoulders

Features

- Basic Instrument consists of: 844 Ag and Measuring Head 44 Ak
- Threaded connection for changing the measuring heads
- Self-Centering measuring head consists of 3 laterally positioned anvils, each are offset at intervals of 120°
- Anvils from 12.5 mm are carbide tipped
- From 12.5 mm the anvils can be used to measure to the bottom of a bore
- From 40 mm all measuring heads are made from aluminum to reduce weight
- Supplied with: Case and operating instructions

The following indicating instruments are recommended:

Indicating instr.	Order no.
MarCator 1086	4337021
MarCator 1087	4337061

Accessories

Measuring heads, ring gages, etc. please refer to page 3-32

Technical Data

Measuring range		Measuring depth mm	Error limit G* µm / inch	Order no.***	
mm	(inch)				
6	- 8	(.25 - .3125")	64 / (139**)	3 / 0.00015	4487600
8	- 10	(.3125 - .4")	64 / (139**)	3 / 0.00015	4487601
10	- 12.5	(.4 - .5")	64 / (139**)	3 / 0.00015	4487602
12.5	- 16	(.5 - .625")	65 / (140**)	3 / 0.00015	4487603
16	- 20	(.625 - .775")	65 / (140**)	3 / 0.00015	4487604
20	- 25	(.775 - 1")	70 / (220**)	3 / 0.00015	4487605
25	- 30	(1" - 1.2")	70 / (220**)	3 / 0.00015	4487606
30	- 35	(1.2 - 1.4")	71 / (221**)	3 / 0.00015	4487607
35	- 40	(1.4 - 1.6")	71 / (221**)	3 / 0.00015	4487608
40	- 50	(1.6" - 2")	79 / (229**)	3 / 0.00015	4487609
50	- 60	(2" - 2.35")	79 / (229**)	4 / 0.00016	4487610
60	- 70	(2.35 - 2.75")	79 / (229**)	4 / 0.00016	4487611
70	- 85	(2.75 - 3.35")	97 / (247**)	4 / 0.00016	4487612
85	- 100	(3.35 - 4")	97 / (247**)	4 / 0.00016	4487613
100	- 125	(4 - 4.9")	132 / (282**)	5 / 0.0002	4487614
125	- 150	(4.9 - 5.9")	132 / (282**)	5 / 0.0002	4487615
150	- 175	(5.9 - 6.9")	132 / (282**)	6 / 0.00025	4487616
175	- 200	(6.9 - 7.9")	132 / (282**)	6 / 0.00025	4487617

Self-Centering Measuring Pistol Set Micromar 844 AS

Measuring range		Number of measuring heads	Ring Gages dia. mm	Order no. with Digital Indicator 1086	Order no.***	
mm	(inch)					
6	- 12.5	(.25 - .5")	3	8 / 10	4487660	4487650
12.5	- 25	(.5 - 1")	3	16 / 20	4487661	4487651
25	- 50	(1 - 2")	4	30 / 40	4487662	4487652
50	- 100	(2 - 4")	4	60 / 85	4487663	4487653

- Supplied with:
1 Basic Instrument 844 Ag, Measuring Heads 44 Ak, case and ring gages (includes a traceable calibration certificate for the ring gages)

* Indicator is not taken into consideration, over the full length of the anvils

** With the extension 44 Av

*** Excludes indicator



Accessories for Micromar 44 A, 44 EX, 844 A

Measuring Heads 44 Ak for 44 EX and 844 A

- Self-centering measuring head consists of 3 laterally positioned anvils, each are offset at intervals of 120°
- Anvils from 12.5 mm are carbide tipped
- From 12.5 mm, anvils can be used to measure to the base of a bore
- From 40 mm all measuring heads are made from aluminum to reduce weight

Measuring range		Order no.
mm	(inch)	
6 - 8	(.25 - .3125")	4190030
8 - 10	(.3125 - .4")	4190031
10 - 12.5	(.4 - .5")	4190032
12.5 - 16	(.5 - .625")	4190033
16 - 20	(.625 - .775")	4190034
20 - 25	(.775 - 1")	4190035
25 - 30	(1" - 1.2")	4190036
30 - 35	(1.2 - 1.4")	4190037
35 - 40	(1.4 - 1.6")	4190038
40 - 50	(1.6" - 2")	4190039
50 - 60	(2" - 2.35")	4190040
60 - 70	(2.35 - 2.75")	4190041
70 - 85	(2.75 - 3.35")	4190042
85 - 100	(2.75 - 3.35")	4190043
100 - 125	(4 - 4.9")	4190044
125 - 150	(4.9 - 5.9")	4190045
150 - 175	(5.9 - 6.9")	4190046
175 - 200	(6.9 - 7.9")	4190047

Meas. range 6 - 12.5 mm

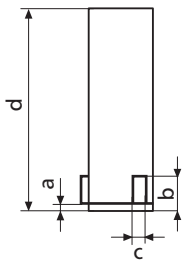

Meas. range 12.5 - 200 mm

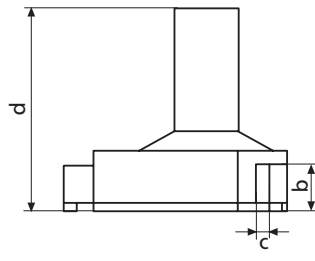

Measuring range	a	b	c	d
mm				
6 - 8	1.3	4.3	2	64
8 - 10	1.8	4.8	2	64
10 - 12.5	2	6	2.5	64
12.5 - 16	-	7	3	65
16 - 20	-	8.5	4	65
20 - 25	-	11	4	70
25 - 30	-	11	4	70
30 - 35	-	12	5	71
35 - 40	-	12	5	71
40 - 50	-	18	5	79
50 - 60	-	18	7	79
60 - 70	-	18	7	79
70 - 85	-	18	7	97
85 - 100	-	18	7	97
100 - 125	-	19	7	132
125 - 150	-	19	7	132
150 - 175	-	19	7	132
175 - 200	-	19	7	132

Ring Gages 44 Ae

- Can be used for 2 consecutive measuring ranges
- Manufacturing tolerance in accordance to DIN 2250C
- Includes a traceable calibration certificate

dia. mm	Order no.	dia. mm	Order no.
8	4190300	40	4190305
10	4190301	60	4190306
16	4190302	85	4190307
20	4190303	125	4190308
30	4190304	175	4190309

Basic Unit 44 EXg

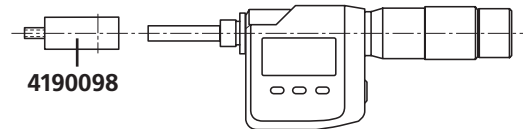

Threaded connection for changing the measuring heads.

Measuring range		Order no.
mm	(inch)	
6 - 12.5	(.25 - .5")	4190104
12.5 - 100*	(.5 - 4.0")	4190105
20 - 100	(.775 - 4.0")	4190101
100 - 200	(4.0 - 7.9")	4190102

* Includes adapter 4190098

Basic Unit Measuring Pistol 844 Ag

Threaded connection for changing the measuring heads. Any indicating instrument with an 8 mm mounting shank can be used.

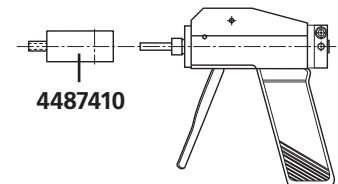

Measuring range		Order no.
mm	(inch)	
6 - 100*	(.25 - 4.0")	4487630
20 - 100	(.775 - 4.0")	4487631
100 - 200	(4.0 - 7.9")	4487632

* Includes adapter 4487410

Depth Extension Rod 44 Av

Measuring range	Length a	dia. b	Order no.
mm	mm	mm	
6 - 10	75	5.8	4190090
10 - 20	75	9.5	4190091
20 - 25	150	19.0	4190092
25 - 200	150	22.0	4190093

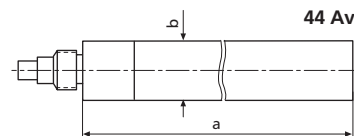

Depth Micrometer Micromar 45 T



Applications

- Depth measurement
- Measuring the space between grooves and groove widths (in conjunction with a Disc anvil 45 Tm)

Features

- Measuring spindle is hardened throughout and ground
- Hardened chrome plated cross beam, the contact surface is lapped
- Hardened anvil
- When using interchangeable extensions recalibrating the depth micrometer is not necessary
- Scales with satin-chrome finish
- Supplied with: Extensions 25 mm and 50 mm, case

Technical Data

Total measuring range mm	Range of micrometer mm	Readings mm	Spindle thread pitch mm	Error limit with standard anvil µm	Extensions mm	Length tolerance of extensions µm	Order no.
0 - 100	25	0.01	0.5	≤5 µm	25/50	± 1.5 µm	4180000

Standard depth measurements

With a standard anvil, if necessary with an extension

Measuring the space between grooves and the widths of a groove

With disc anvil 45 Tm, if necessary with an extension

Dimension A: Can be direct read of the thimble

Dimension B: The reading plus 1.00 mm (thickness of the disc anvil)

*Dimension C:
Dimension B minus Dimension A*

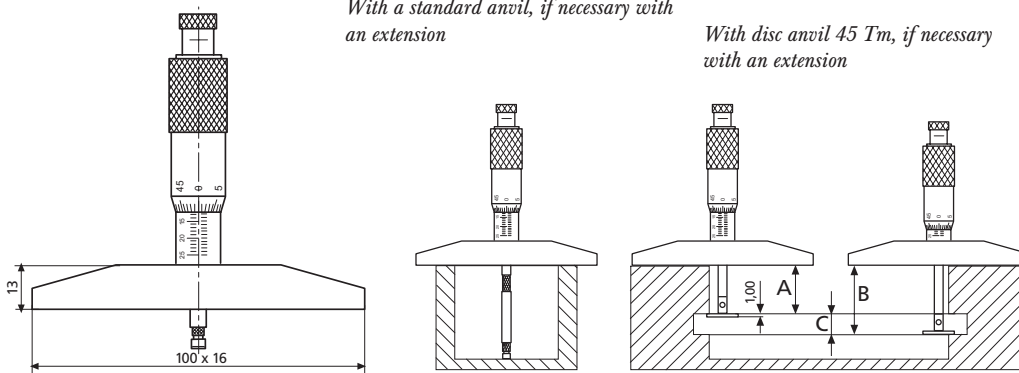

Accessories

Disc anvil 45 Tm
for groove spacing and groove widths

Order no.

4180011

Extension 45 Tv

Length L

Length tolerance

25 mm	± 1.5 µm	4180001
50 mm	± 1.5 µm	4180002
100 mm	± 1.5 µm	4180003

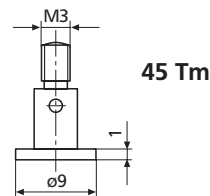

Digital Micrometer Head Micromar 46 EX

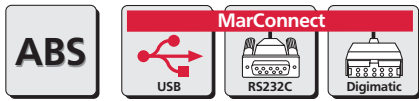

Features

Functions:

0 (Zero setting)
 ABS (Switch between Relative and Absolute measurement)
 mm/inch
 PRESET (enter a numerical value)
 DATA (Data transmission via connection cable)

- Patented capacitive measuring system with an energy saving function, life of the battery approx. 2 years
- Ratchet with integrated coupler
- Supplied with:
 Case, end cap (in case the rapid drive is not required) and operating instructions

Technical Data

Measuring range		Readings	Error limit G_{me}	Measuring face	Mounting shaft	Order no.
mm	(inch)	mm/inch	μm		mm	
0-25	(0-1")	0.001/0.0005"	4	flat	12	4184301
0-25	(0-1")	0.001/0.0005"	4	flat	12*	4184303
0-25	(0-1")	0.001/0.0005"	4	spherical	12	4184302
0-25	(0-1")	0.001/0.0005"	4	spherical	12*	4184304

* with locking nut

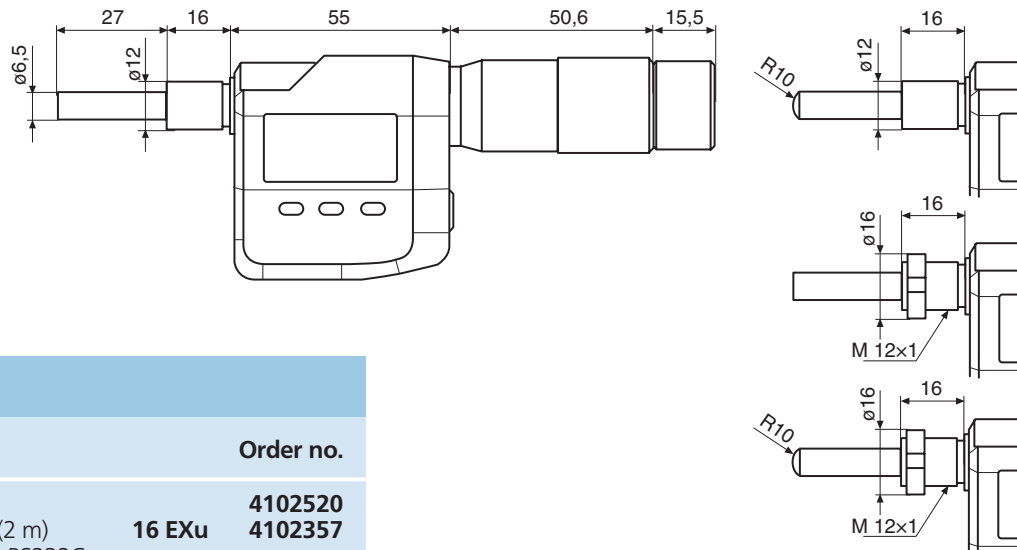

Accessories

	Order no.
Battery 3V, type CR 2032	4102520
Data Connection Cable USB (2 m)	16 EXu 4102357
Data Connection Cable Opto RS232C (2 m), with SUB-D jack 9-pin	16 EXr 4102410
Data Connection Cable Digimatic (2 m), Flat plug 10-pin	16 EXd 4102411

Accessories for Data Processing see Chapter 11

Micrometer Head Micromar 46



Features

- Spindle is made of stainless steel, hardened throughout and ground
- Scales with satin-chrome finish

Technical Data

	Measuring range	Readings	Error limit		Spindle thread pitch	Spindle dia.	Order no.
			G_{me}	DIN 863			
	mm	mm	μm		mm	mm	
46	0 - 6.5	0.01	3	●	0.5	3.5	4183021
	0 - 13	0.01	3	●	0.5	5	4183025
	0 - 25	0.01	3	●	0.5	6.35	4183030
	0 - 25*	0.01	3	●	0.5	6.35	4183024
	0 - 50	0.01	5		0.5	7.5	4183023
46 H	0 - 25**	0.01	3	●	0.5	7.5	4184000

* with locking nut

** with ratchet, carbide tipped

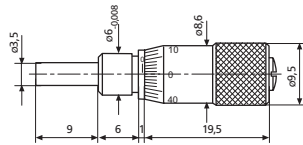

4183021
Measuring range 0-6.5 mm

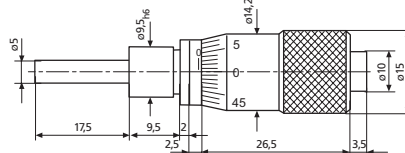

4183025
Measuring range 0-13 mm

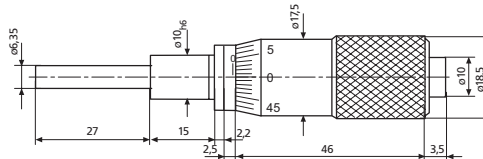

4183030
Measuring range 0-25 mm

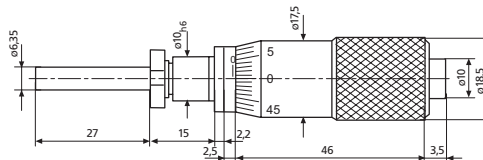

4183024
Measuring range 0-25 mm with locking nut

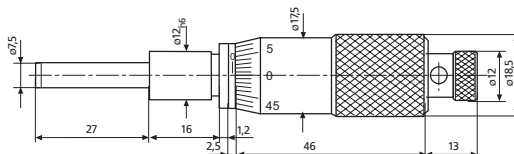

4184000
Measuring range 0-25 mm carbide tipped

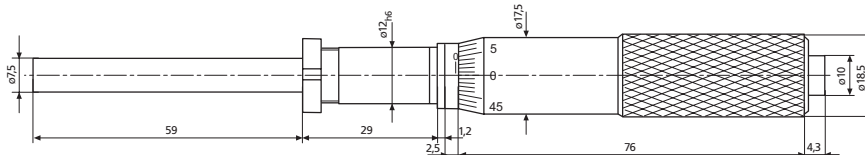

4183023
Measuring range 0-50 mm

YOUR MEASURING TASKS ARE SENSITIVE. MARTEST IS HIGHLY SENSITIVE.



The latest information on MARTEST products can be found on our website:

www.mahr.com, WebCode 10407

► | Since 1936 Mahr is one of the leading global producers of test indicators, we have achieved this with the continuous advancement of our products and with unrelenting commitment to produce high quality products that not only meet customer requirements but also exceed them. We have also increased research and development in order to satisfy the demands and requirements of the market, however our core philosophy is to offer our customer a highly accurate and simple solution for various measuring tasks. With the MarTest series of test indicators there is not just a broad product range but also a wide variety of accessories at your disposal. The sensitive computer-optimized shockproof mechanism of the test indicator ensures maximum security and precision. MarTest is ideal for use in workshop conditions due to the dial being sealed thus impervious to the penetration of liquids.

▶ | MarTest. Test Indicators and Touch Probes

Mechanical Test Indicators with Dial Overview

4- 2

Standard version

MarTest 800 S / 800 SG / 800 SA / 800 SGA

metric

4- 4

MarTest 801 S1 / 801 S / 801 SG / 801 SGI

inch

4- 4

With a higher resolution

MarTest 800 SM / 800 SGM / 800 SGE

metric

4- 5

MarTest 801 SM / 801 SGM / 801 SGE

inch

4- 5

With a longer styli

MarTest 800 SL / 800 SGL / 800 SGB

metric

4- 6

MarTest 801 SL / 801 SGL

inch

4- 6

Horizontal version

MarTest 800 H

metric

4- 7

MarTest 801 H

inch

4- 7

Vertical version

MarTest 800 V / 800 VGM

metric

4- 7

MarTest 801 V / 801 VGM

inch

4- 7

With a larger measuring range

MarTest 800 SR / 800 SRM

metric

4- 8

MarTest 801 SR / 801 SRM

inch

4- 8

Digital Test Indicators

Standard version

MarTest 800 EW

4- 9

With a longer styli

MarTest 800 EWL

4-10

Accessories

4-11

3D-Touch Probes

Water proof, with a Digital display

MarTest 802 NW

4-14

Water proof, with an Analog display







MarTest 802 EW

4-15

MarTest. Test Indicators

OVERVIEW

MarTest - Versions

		Measuring range	Dial style	Readings	DIN 2270	f _{ges}	f _e	f _u	f _t	f _w
 <p>Standard</p>	metric									
	800 S	+/- 0.4 mm	0-40-0	0.01 mm	●	13 µm	10 µm	3 µm	5 µm	3 µm
	800 SG	+/- 0.4 mm	0-40-0	0.01 mm	●	13 µm	10 µm	3 µm	5 µm	3 µm
	800 SA	+/- 0.25 mm	0-25-0	0.01 mm		8 µm	5 µm	3 µm	5 µm	3 µm
	800 SGA	+/- 0.25 mm	0-25-0	0.01 mm		8 µm	5 µm	3 µm	5 µm	3 µm
	inch									
	801 S1	+/- .015"	0-15-0	.001"		.0005"	.0004"	.00012"	.0002"	.0002"
	801 S	+/- .015"	0-15-0	.0005"		.0005"	.0004"	.00012"	.0002"	.0002"
	801 SGI	+/- .015" (+/-0.30 mm)	0-15-0 (0-30-0)	.001" (0.01 mm)		.0005"	.0004"	.00012"	.0002"	.0002"
 <p>Extra Long Styli</p>	metric									
	800 SL	+/- 0.25 mm	0-25-0	0.01 mm		13 µm	10 µm	5 µm	5 µm	3 µm
	800 SGL	+/- 0.25 mm	0-25-0	0.01 mm		13 µm	10 µm	5 µm	5 µm	3 µm
	800 SGB	+/- 0.5 mm	0-50-0	0.01 mm		13 µm	10 µm	4 µm	5 µm	3 µm
	inch									
	801 SL	+/- .010"	0-10-0	.0005"		.0005"	.0004"	.0002"	.0002"	.00012"
 <p>Higher Resolution</p>	metric									
	800 SM	+/- 0.1 mm	0-100-0	0.002 mm	●	4 µm	3 µm	2 µm	2 µm	1.5 µm
	800 SGM	+/- 0.1 mm	0-100-0	0.002 mm	●	4 µm	3 µm	2 µm	2 µm	1.5 µm
	800 SGE	+/- 0.07 mm	0-70-0	0.001 mm		4 µm	3 µm	2 µm	2 µm	1.5 µm
	inch									
	801 SM	+/- .004"	0-4-0	.0001"		.00016"	.00012"	.00008"	.00008"	.00006"
 <p>Larger Measuring Range</p>	metric									
	800 SR	+/- 0.8 mm	0-40-0	0.01 mm		14 µm	10 µm	4 µm	5 µm	3 µm
	800 SRM	+/- 0.2 mm	0-100-0	0.002 mm		5 µm	3 µm	3 µm	2 µm	1.5 µm
	inch									
	801 SR	+/- .030"	0-15-0	.0005"		.0005"	.0004"	.00016"	.0002"	.00012"
	801 SRM	+/- .008"	0-4-0	.0001"		.0002"	.00012"	.00012"	.00008"	.00006"
 <p>Horizontal Models</p>	metric									
	800 H	+/- 0.4 mm	0-40-0	0.01mm	●	13 µm	10 µm	3 µm	5 µm	3 µm
	inch									
 <p>Vertical Models</p>	metric									
	800 V	+/- 0.4 mm	0-40-0	0.01 mm	●	13 µm	10 µm	3 µm	5 µm	3 µm
	800 VGM	+/- 0.1 mm	0-100-0	0.002 mm	●	4 µm	3 µm	2 µm	2 µm	1.5 µm
	inch									
	801 V	+/- .015"	0-15-0	.0005"		.0005"	.0004"	.00012"	.0002"	.00012"

* Only available in North America, Canada and Mexico; includes holding bar and clamp

Length of Styli	Order no.	Order no. with kit*
14.5 mm	4305200	2015309
14.5 mm	4307200	2015310
14.5 mm	4301200	2015343
14.5 mm	4301250	2015344
14.5 mm	4305960	2015317
14.5 mm	4305950	2015316
14.5 mm	4307950	2015318
14.5 mm	4307970	2015311
41.24 mm	4306200	2015312
41.24 mm	4306250	2015313
32.3 mm	4301300	2015346
41.24 mm	4306950	2015319
41.24 mm	4306960	2015320
14.5 mm	4308150	2015315
14.5 mm	4308200	2015314
9.1 mm	4308220	2015345
14.5 mm	4308960	2015321
14.5 mm	4308970	2015322
14.5 mm	4308985	2015323
14.5 mm	4307250	2015348
14.5 mm	4308250	2015349
14.5 mm	4307960	2015350
14.5 mm	4308980	2015351
14.5 mm	4303200	2015328
14.5 mm	4303950	2015324
14.5 mm	4302200	2015327
14.5 mm	4302250	2015347
14.5 mm	4302950	2015325
14.5 mm	4302960	2015326

Metrological characteristics

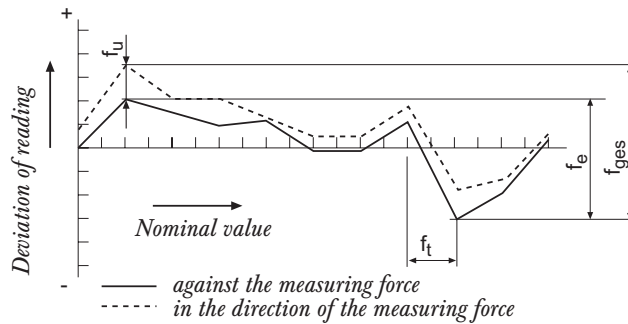

MarTest - Design features

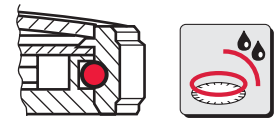

Mechanism

- Shockproof
- Anti magnetic
- Movement bearings are jeweled with 8 precious stones
- Automatic matching to sensing direction, thus ensuring error-free reading

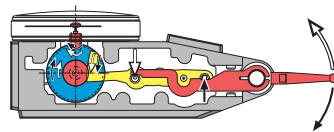

- Dial face is sealed with an O-Ring
- Satin chrome finished housing
- Double lever supported in ball bearings, overload protection provided by slip clutch
- Contact point with carbide ball

MarTest - Applications

Concentricity of a shaft



Concentricity of a sleeve



Centering of a bore



Aligning a surface



Testing parallelism



MarTest standard versions

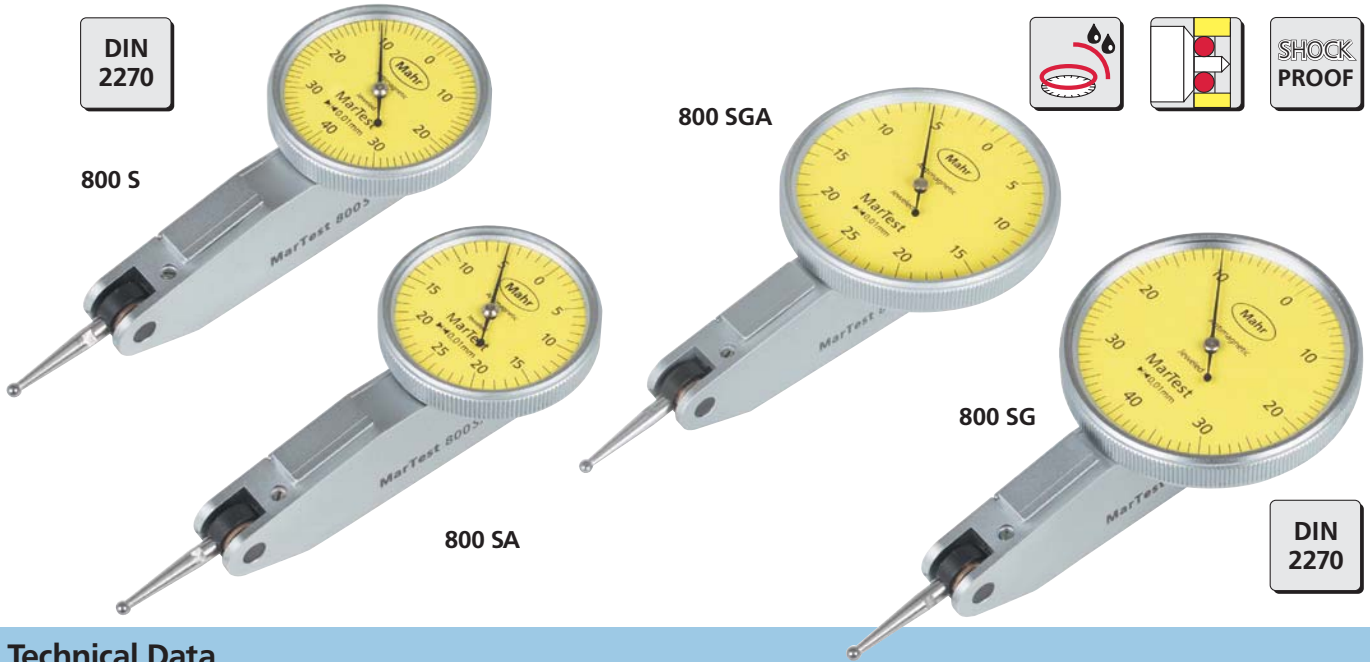

Technical Data

	Measuring range	Readings	Dial dia.	Measuring force	Length of styli	Order no.	Order no. with kit
800 S	± 0.4 mm	0.01 mm	27.5 mm	0.15 N	14.5 mm	4305200	2015309
800 SG	± 0.4 mm	0.01 mm	38 mm	0.15 N	14.5 mm	4307200	2015310
800 SA	± 0.25 mm	0.01 mm	27.5 mm	0.1 N	14.5 mm	4301200	2015343
800 SGA	± 0.25 mm	0.01 mm	38 mm	0.1 N	14.5 mm	4301250	2015344
801 S1	± .015"	.001"	1.1"	0.15 N	14.5 mm	4305960	2015317
801 S	± .015"	.0005"	1.1"	0.15 N	14.5 mm	4305950	2015316
801 SG	± .015"	.0005"	1.5"	0.15 N	14.5 mm	4307950	2015318
801 SGI	± .015" (± 0.3 mm)	.0005" (0.01 mm)	1.5"	0.15 N	14.5 mm	4307970	2015311

Supplied with:

Plastic storage case, spanner for changing the styli, styli dia. 2 mm, mounting shaft 800 a8 (for metric versions), mounting shaft 800 a6 (800 SA, 800 SGA), mounting shaft 800 a3/8 (for inch versions)

801 S1

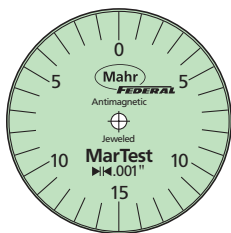

801 S

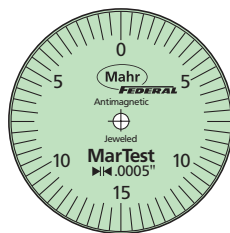

801 SG

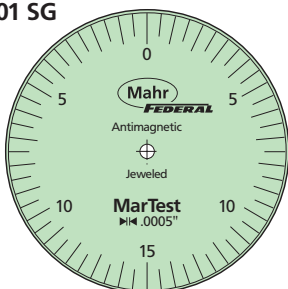

801 SGI

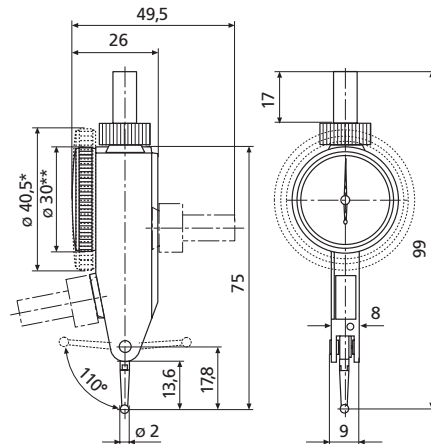
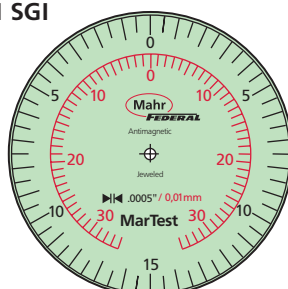

* 800 SG, 800 SGA, 801 SG, 801 SGI
 ** 800 S, 800 SA, 801 S1, 801 S

MarTest with resolution 0.002 mm/0.001 mm for higher accuracy

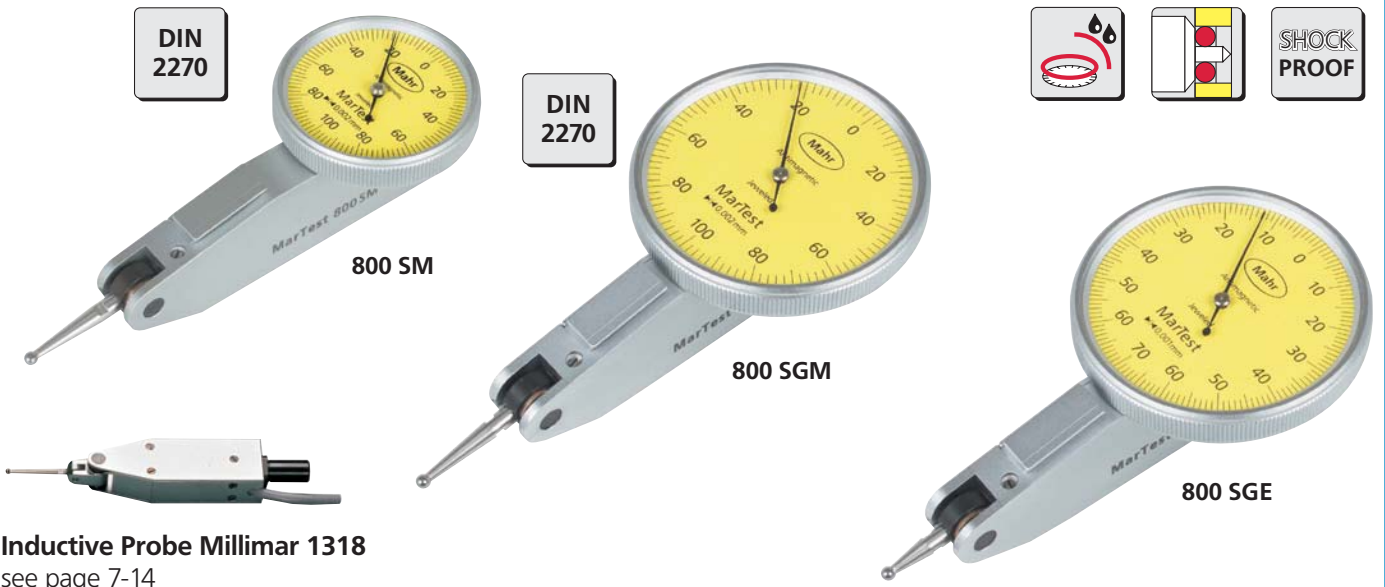

Inductive Probe Millimar 1318
see page 7-14

Technical Data

	Measuring range	Readings	Dial dia.	Measuring force	Length of styli	Order no.	Order no. with kit
800 SM	± 0.1 mm	0.002 mm	27.5 mm	0.15 N	14.5 mm	4308150	2015315
800 SGM	± 0.1 mm	0.002 mm	38 mm	0.15 N	14.5 mm	4308200	2015314
800 SGE	± 0.07 mm	0.001 mm	38 mm	0.2 N	9.1 mm	4308220	2015345
801 SM	± .004"	.0001"	1.1"	0.15 N	14.5 mm	4308960	2015321
801 SGM	± .004"	.0001"	1.5"	0.15 N	14.5 mm	4308970	2015322
801 SGE	± .004"	.00005"	1.5"	0.15 N	14.5 mm	4308985	2015323

Supplied with:

Plastic storage case, spanner for changing the styli, styli dia. 2 mm, mounting shaft 800 a8 (for metric versions)

801 SM

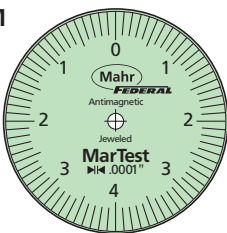

801 SGM

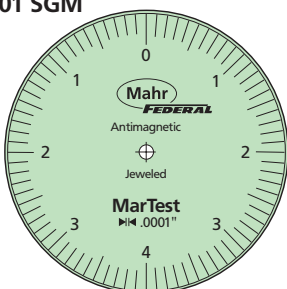

801 SGE

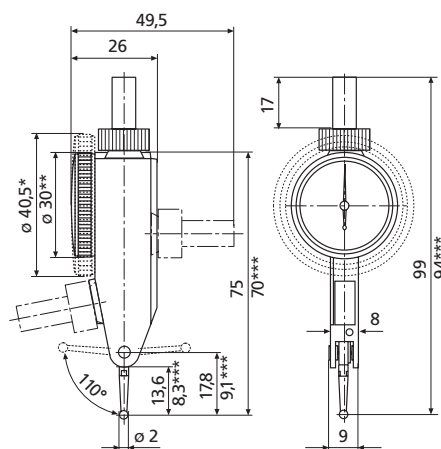
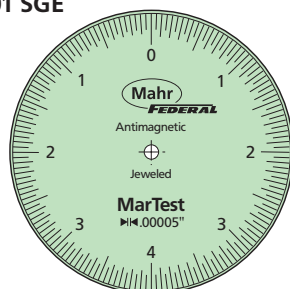

* 800 SGM, 800 SGE, 801 SGM, 801 SGE
** 800 SM, 801 SM
*** 800 SGE

MarTest with extra long styli for measuring in even difficult to access positions



Technical Data

	Measuring range	Readings	Dial dia.	Measuring force	Length of styli	Order no.	Order no. with kit
800 SL	± 0.25 mm	0.01 mm	27.5 mm	0.07 N	41.24 mm	4306200	2015312
800 SGL	± 0.25 mm	0.01 mm	38 mm	0.07 N	41.24 mm	4306250	2015313
800 SGB	± 0.5 mm	0.01 mm	38 mm	0.07 N	32.3 mm	4301300	2015346
801 SL	± .010"	.0005"	1.1"	0.07 N	41.24 mm	4306950	2015319
801 SGL	± .010"	.0005"	1.5"	0.07 N	41.24 mm	4306960	2015320

Supplied with:

Plastic storage case, spanner for changing the styli, styli dia. 2 mm, mounting shaft 800 a8 (for metric versions), mounting shaft 800 a3/8 (for inch versions), mounting shaft 800 a6 (800 SGB)

801 SL

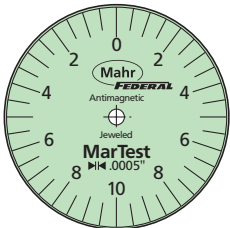

801 SGL

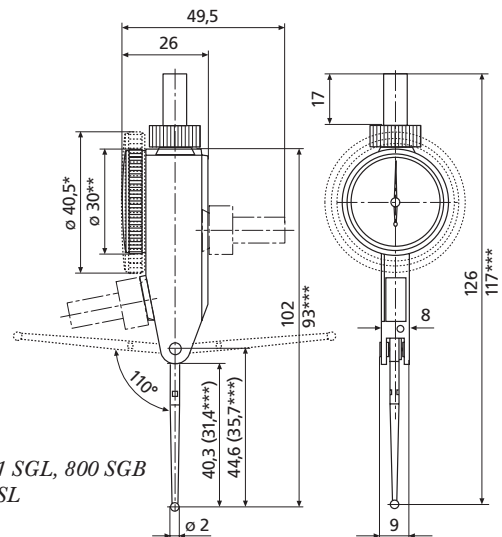
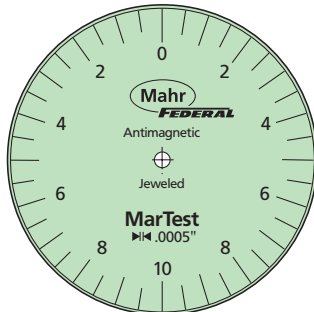

* 800 SGL, 801 SGL, 800 SGB
 ** 800 SL, 801 SL
 *** 800 SGB

MarTest styli can positioned horizontally to the dial face

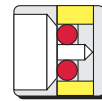
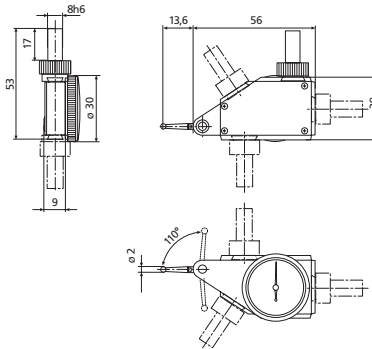

800 H

Technical Data

	Measuring range	Readings	Dial dia.	Measuring force	Length of styli	Order no.	Order no. with kit
800 H	± 0.4 mm	0.01 mm	27.5 mm	0.25 N	14.5 mm	4303200	2015328
801 H	± .015"	.0005"	1.1"	0.25 N	14.5 mm	4303950	2015324

Supplied with:

Plastic storage case, spanner for changing the styli, styli dia. 2 mm, mounting shaft 800 a8 (for metric versions), mounting shaft 800 a3/8 (for inch versions)

MarTest vertical model



800 V

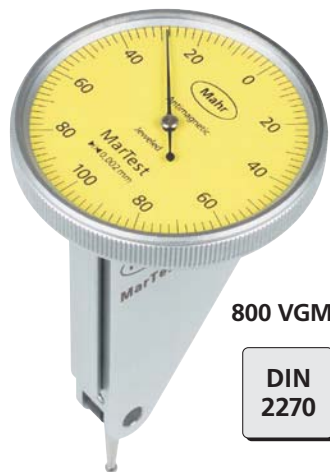

800 VGM

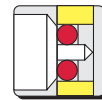
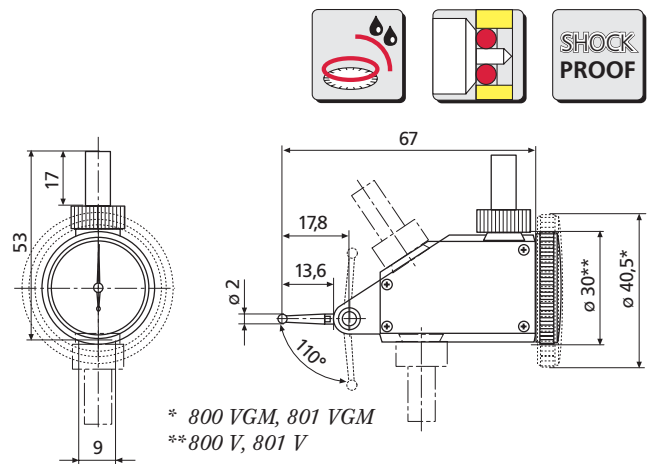

Technical Data

	Measuring range	Readings	Dial dia.	Measuring force	Length of styli	Order no.	Order no. with kit
800 V	± 0.4 mm	0.01 mm	27.5 mm	0.2 N	14.5 mm	4302200	2015327
800 VGM	± 0.1 mm	0.002 mm	38 mm	0.25 N	14.5 mm	4302250	2015347
801 V	± .015"	.0005"	1.1"	0.2 N	14.5 mm	4302950	2015325
801 VGM	± .004"	.0001"	1.5"	0.25 N	14.5 mm	4302960	2015326

Supplied with:

Plastic storage case, spanner for changing the styli, styli dia. 2 mm, mounting shaft 800 a8 (for metric versions), mounting shaft 800 a3/8 (for inch versions)

MarTest with larger measuring range



800 SRM

800 SR/SRM

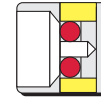
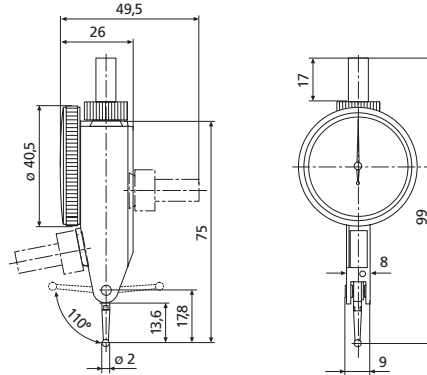

Technical Data

	Measuring range	Readings	Dial dia.	Measuring force	Length of styli	Order no.	Order no. with kit
800 SR	± 0.8 mm	0.01 mm	38 mm	0.15 N	14.5 mm	4307250	2015348
800 SRM	± 0.2 mm	0.002 mm	38 mm	0.15 N	14.5 mm	4308250	2015349
801 SR	± .030"	.0005"	1.5"	0.15 N	14.5 mm	4307960	2015350
801 SRM	± .008"	.0001"	1.5"	0.15 N	14.5 mm	4308980	2015351

Supplied with:

Plastic storage case, spanner for changing the styli, styli dia. 2 mm, mounting shaft 800 a8 (for metric versions), mounting shaft 800 a3/8 (for inch versions)

MarTest - Accessories

Styluses

with ruby contact points

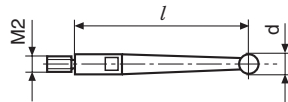

Styluses

with carbide contact points



Spanner for changing the styluses

4305868



Model	Stylus-length <i>l</i>	Styluses			Ruby contact point									
		Carbide contact point		Ruby contact point										
		Cat.-no.	dia. 1 mm	dia. 2 mm	dia. 3 mm	Cat.-no.	dia. 2 mm							
800 S/801 S1/801 S 800 SG/801 SG 800 SA 800 SGA 800 SM/801 SM 800 SGM/801 SGM 801 SGE 800 SR/801 SR 800 SRM/801 SRM 800 H/801 H 800 V/801 V 800 VGM/801 VGM	14.5 mm	800 ts	4305870	4305850	4305871	800 tsr	4309051							
800 SGE								800 te	4308851	4308850	4308852	800 ter	4309050	
800 SL/801 SL 800 SGL/801 SGL								41.24 mm	800 tl	4306851	4306850	4306853	800 tlr	4309053
800 SGB														

Digital Test Indicator MarTest 800 EW



Features

Functions:

- ON/OFF
 - RESET (Set display to zero)
 - mm/inch
 - MAX/MIN memory
 - MAX-MIN ideal for testing concentricity and flatness
 - Auto-OFF
- Operating and display unit (bezel) can be rotated through 360°
 - Satin chrome finished housing with 3 dovetail guideways
 - Shockproof, movement bearings are jewelled
 - Automatic matching to sensing direction
 - Anti-magnetic
 - Double lever supported in ball bearings, overload protection provided by slip clutch
 - Supplied with: Plastic case, spanner to change the styluses, contact point $\varnothing 2\text{mm}$, mounting shaft 800h8
- Inductive measuring system, battery life span ca. 2 years
 - MarConnect data output, choose alternatively:
 - USB
 - OPTO RS232C
 - Operating unit is protected against coolants and lubricants, protection class IP65
 - Combined analog and digital display

Technical Data

	Measuring range mm (inch)	Resolution switchable mm/inch	Measuring force N	Accuracy μm		Length of styli mm / inch	Order no.
				f_e	f_u		
800 EW	+/-0.4 (+/-0.15")	0.001/0.0005" 0.01/0.005"	0.13	10	3	14.5 / .500"	4305120

Accessories

	Order no.
Styli, with carbide contact point dia. 1 mm	4305870
Styli, with carbide contact point dia. 2 mm	4305850
Styli, with carbide contact point dia. 3 mm	4305871
Styli, with ruby contact point dia. 2 mm	4309051
Battery 3V, Type CR 2032	4102520
Data Connection Cable USB	800 EWu 4305121
Data Connection Cable Opto RS232	800 EWr 4305122

Accessories for Data Processing Chapter 11

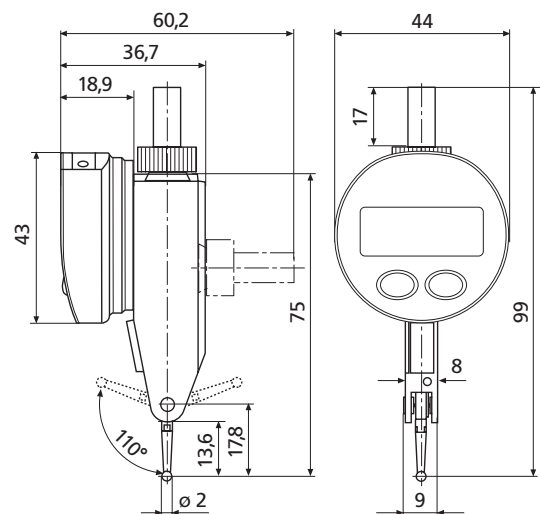

Digital Test Indicator MarTest 800 EWL



Features

Functions:

- ON/OFF
- RESET (Set display to zero)
- mm/inch
- MAX/MIN memory
- MAX-MIN ideal for testing concentricity and flatness
- Auto-OFF
- Operating and display unit (bezel) can be rotated through 360°
- Satin chrome finished housing with 3 dovetail guideways
- Shockproof, movement bearings are jewelled
- Automatic matching to sensing direction
- Anti-magnetic
- Double lever supported in ball bearings, overload protection provided by slip clutch
- Supplied with: Plastic case, spanner to change the styluses, contact point $\varnothing 2\text{mm}$, mounting shaft 800h8
- Inductive measuring system, battery life span ca. 2 years
- MarConnect data output, choose alternatively:
 - USB
 - OPTO RS232C
- Operating unit is protected against coolants and lubricants, protection class IP65
- Combined analog and digital display

Technical Data

	Measuring range	Resolution	Measuring force	Accuracy		Length of styli	Order no.
	mm (inch)	switchable mm/inch	N	f_e	f_u	mm / inch	
800 EWL	+/-0.25 (+/-0.010")	0.001/0.0005" 0.01/0.0005"	0.07	10	3	41.24 / 1 7/16"	4306120

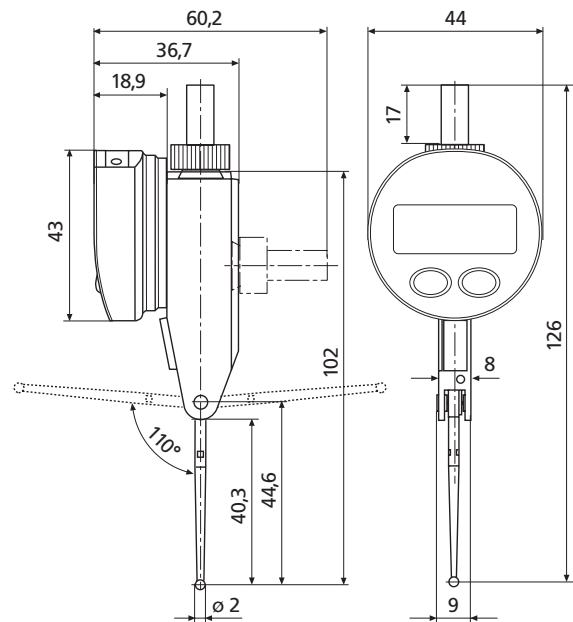

Zubehör

	Order no.
Styli, with carbide contact point dia. 1 mm	4306851
Styli, with carbide contact point dia. 2 mm	4306850
Styli, with carbide contact point dia. 3 mm	4306853
Styli, with ruby contact point dia. 2 mm	4309853
Battery 3V, Type CR 2032	4102520
Data Connection Cable USB	800 EWu 4305121
Data Connection Cable Opto RS232	800 EWr 4305122

Martest - Accessories

Mounting shaft for dovetail

Mounting shaft	dia. d mm	Order no.
800 a8	8	4305865
800 a6	6	4301865
800 a4	4	4305885
800 a1/4	1/4"	4305895
800 a3/8	3/8"	4305875

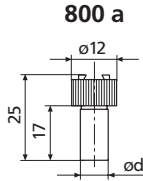

Stand 801 p



- With swivel holder
- Base with V-groove 140°
- Total height 150 mm
- Mounting bore dia. 4 and 8 mm
- Column dia. 8 mm
- Base surface 65 x 40 mm

Order no. 4309090

Indicator not included.

Centering support rods 801 v

- For aligning and centering work pieces on machine tools
- Swivel mounting clamp and fine adjustment
- Stainless steel rods

Mounting bore dia. 8 mm
Swivel range of mounting clamp 180°

Order no. 4309070

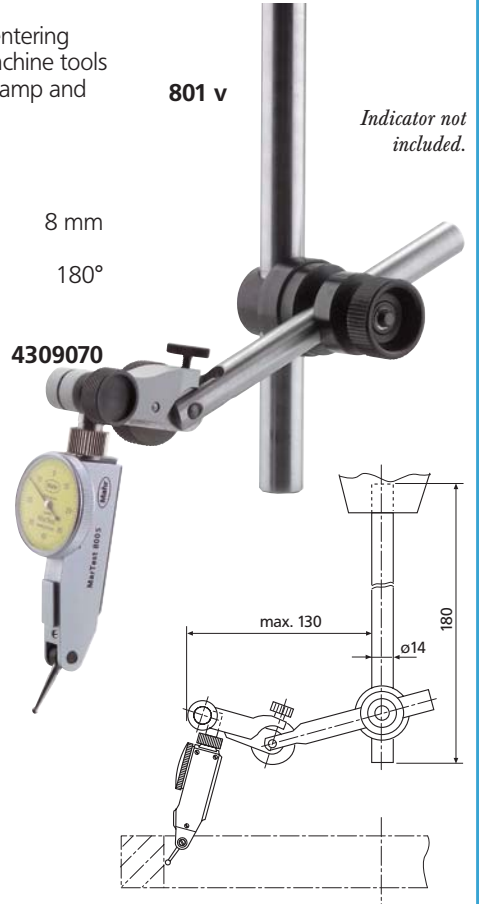

Indicator not included.

Leveling Table TE-20

Cuts set-up time 60% or more for many height gage measurements.

- The leveling table, TE-20, permits you to quickly bring the surface of a part into alignment with a surface plate in both planes. Completely eliminates shimming. Saves so much time that, used only occasionally, it will pay for itself in two weeks.
- The top plate is stress-relieved steel providing about 67 square inches of work area. It is drilled and tapped for fixtures. Fine pitch screws and large knobs assure precisely controlled adjustments. Works with any type of height gage.
- Operation is simple. Height gage readings are taken at edges of the surface to be aligned. Each plate, independently adjustable at right angles to the other, is angled as required for precise alignment.
Flatness = .025 mm / .001"



Typical checks which require careful positioning of work because rest surface is not sufficiently parallel to other work surfaces. Leveling Table compensates for error quickly, drastically reduces set-up time.

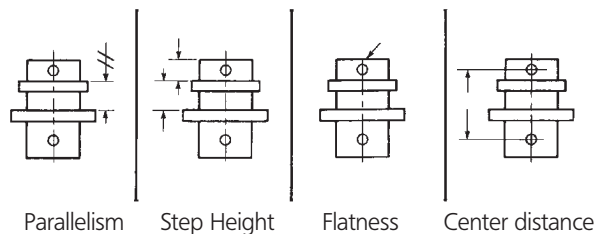

Adjustment	Top Plate	Bottom Plate
Total	± 1° 30'	± 1° 30'

Martest - Accessories

Holder 800 h

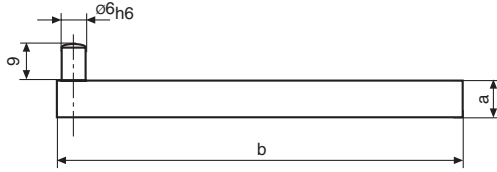

	Dimensions		Order no.
800 h1	a	b	4305888
800 h2	9x9	100	4305889
	1/4" x 1/2"	4"	

Universal centering support frame 800 b Order no. 4305893

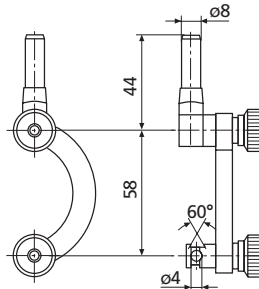

Indicator not included.

Universal clamp 800 k

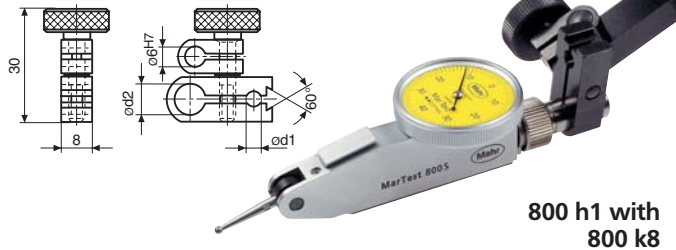

800 h1 with
800 k8

	Dimensions		Order no.
800 k8	dia. d1	dia. d2	4305891
800 k3/8	4	8	4305892
	5/32"	3/8"	

Indicator not included.

Universal holder with dovetail clamp

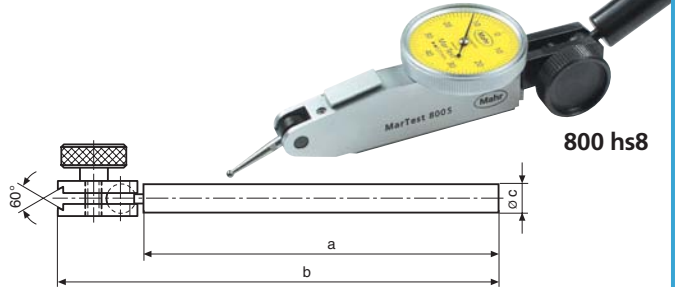

800 hs8

	Dimensions			Order no.
800 hs8	a	b	dia. c	4305886
800 hs3/8	100	124	8	4305887
	4"	5"	3/8"	

Indicator not included.

Ball Clamp

- Dovetail and ball for indicator mounting and omni-directional orientation

Order no.

AT-50

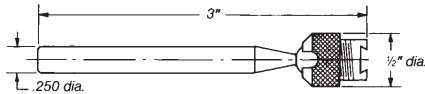

Jig Borer Attachment

- Furnished with two rods and clamp for fast machine mounting

Order no.

RD-21

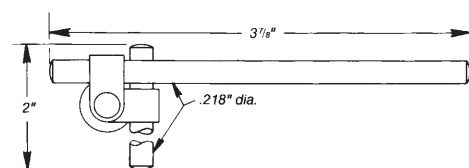

Double-jointed Clamp

- Reaches up to 127 mm / 5" with easy positioning for many applications including milling machine and Jig Borers

Order no.

AT-100

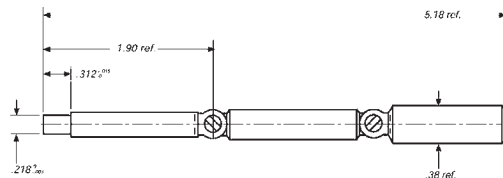

Holding Bar

- Normally furnished with MarTest models. Three-inch length provides ample reach for most applications

Order no.

HB-2157

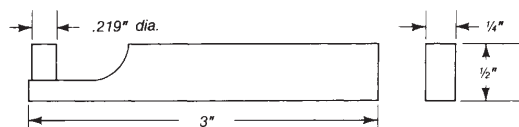

Swivel Clamp

- Normally furnished with MarTest models. Allows indicator to be mounted on most indicator stands and fixtures

Order no.

CP-2199

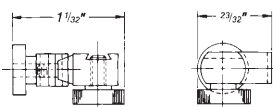

Martest - Accessories

Test Stand 1492B

- Use with any MarTest Indicator - Support arms stepped at one end (.218in dia.) for Swivel Clamp (CP-2199) included.
- Accommodates Vertical and Horizontal lug back mounts for AGD type Indicators.
- Bases have powerful "ON/OFF" permanent magnets which hold from any of four faces - three sides or bottom.



Indicator not included.

Base Dimensions		Main Post		Support Arm		Order no.
mm	W x L x H (inch)	Length mm/inch	Diameter mm/inch	Length mm/inch	Diameter mm/inch	
60 x 48 x 59	(2.4" x 1.9" x 2.2")	178/ 7"	10/ .47"	165/ 6.5"	9.9/ .39"	1492B-5
60 x 48 x 59	(2.4" x 1.9" x 2.2")	178/ 7"	10/ .47"	149/ 5.9"	9.9/ .39"	1492B-10
114 x 48 x 59	(4.5" x 1.9" x 2.2")	401/ 15.8"	20/ .79"	200/ 7.9"	14/ .55"	1492B-15

*Measurements are mm/inch. All models furnished with post clamp and indicator mounting clamp.
Style 1492B-10 has fine adjustment on post clamp.*

Transfer Stand 2300

- Fine adjustment conveniently located in base.
- Three-point base pads improve accuracy.
- Contoured shape facilitates movement.
- Use with any Testmaster Indicator - stud accommodates Swivel Clamp (CP-2199).
- EHE-2048 Gage head requires a CP-116 Clamp.



Indicator not included.

Base Dimensions		Column	Maximum vertical capacity	Reach (base to contact point)	Mounting stud dia.	Order no.
mm	W x L x H (inch)	(dia. x H) mm/inch	mm/inch	mm/inch	mm/inch	
76 x 110 x 45	(3 x 4.375 x 1.75")	25 x 430/ .995 x 17"	457/ 18"	approx. 86/ 3.375"	5.55/ .218"	2300

Mechanical 3D-Touch Probe MarTest 802 NW



Applications

Can be used on milling and CNC machines to

- determine the zero position on a work piece
- determine the center of a bore
- determine and correct the position of a work piece

and for measurement of

- lengths
- depths

Features

- High accuracy and linearity
 - suitable for measuring work pieces
 - measurement over the entire working range is possible
- Can be controlled independently of a machine tool
- Easy to read display
- Large working range in all axis (X, Y, Z) prevents damage to the stylus by contacting errors
- Shock and Water proof, ideal for the use on a machine with a tool changer
- Compact metal housing and long probe arm
- Supplied with: Operating instructions

Technical Data

	Repeatability in zero position unidirectional	Readings	Dial dia.	Mounting shaft dia.	Order no.
802 NW	± 0.01 mm	0.01 mm	50 mm	16 mm	4304311

Accessories

Styli	dia. d mm	l mm	Order no.
802 EWt	4	31	4304320
802 NWt	6	56.6	4304321

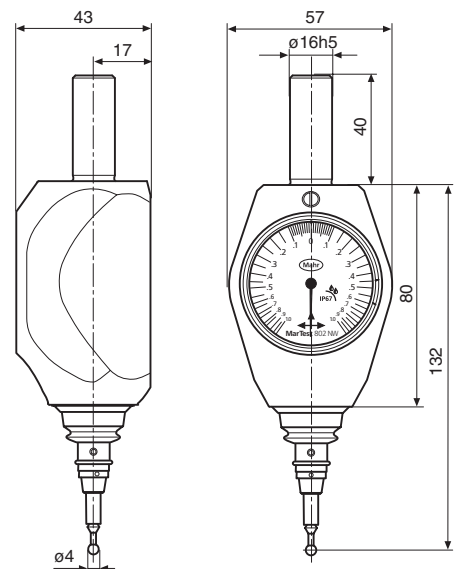
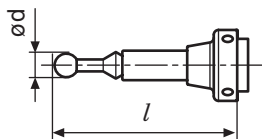

Digital 3D-Touch Probe MarTest 802 EW

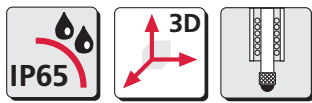

Applications

Can be used on milling and CNC machines to

- determine the zero position on a work piece
- determine the center of a bore
- determine and correct the position of a work piece

and for measurement of

- lengths
- depths

Features

- High accuracy and linearity
 - suitable for measuring work pieces
 - measurement over the entire working range is possible
- Can be controlled independently of a machine tool
- Easy to read display due to the combination of:
 - a progressive analog display (bar graph) for dynamic path information
 - a digital display for accurate reading
- Large working range (6 mm) in all axis (X, Y, Z) prevents damage to the stylus by contacting errors
- Shock and water proof; ideal for the use on a machine with a tool changer
- Compact metal housing and long probe arm
- Supplied with:
 - Battery and operating instructions

Technical Data

	Working range X, Y, Z-Axis unidirectional	Repeatability in zero position display	Resolution of digital	Display range	Mounting shaft dia.*	Order no.
802 EW	-2 to +4 mm	± 0.005 mm	0.005 mm	± 2 mm	16 mm	4304300
802 EWZ	-.0787" to .157"	± .0001"	.0001"	± .0787"	3/4"	4304305

* Further mounting shafts are available on request

Accessories

Styli	dia. d mm	l mm	Order no.
802 EWt	4	31	4304320

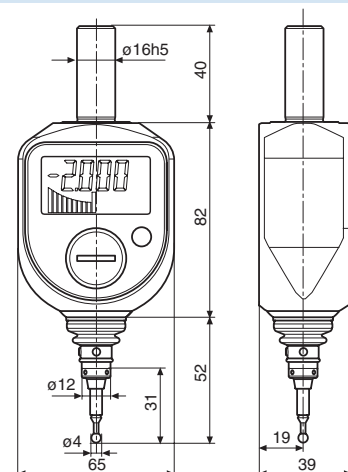
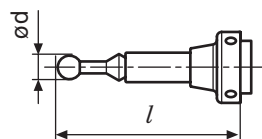

THEY POINT YOU IN THE RIGHT DIRECTION. MARCATOR DIAL INDICATORS.



The latest information on MARCATOR products can be found on our website:
www.mahr.com, WebCode 206

► | Dial indicators due to their versatility rank as the most frequently applied transducer, just like our MarCator series. Our mechanical dial indicators have precision gears and pinions for a maximum accuracy. They are also available in shock and waterproof versions. Our digital indicator range contains highly precise electronic measuring systems, which make measuring functions possible yet without the loss of an analog display. With the simple operation, the large display that can be read error free and the possibility of a rapid and simple transmission of all your measurement results thus meeting all requirements of a modern measuring instrument.

▶ | MarCator. Dial and Digital Indicators

ANSI/AGD Dial Indicators

Overview

5- 2

Dial Indicators ANSI/AGD Groups 0, 1, 2, 3, 4

5- 7

Single Revolution Dial Indicator

5-13

Long Range and Extra Long Range Dial Indicator

5-15

Wetproof Dial Indicator Series WC & WP

5-17

Perpendicular Dial Indicator

5-19

Accessories for ANSI/AGD Dial Indicators

5-21

Dial Indicators - Testing and Calibration Products

5-25

Contact Points for ANSI/AGD Dial Indicators

5-27

DIN Style Precision Dial Indicators

Overview

5-28

MarCator 803 A / 805 A / 803 S / 803 SW / 803 SB / 803 AZ

5-30

Small Dial Indicators

MarCator 810 A / 810 AT / 810 S / 810 SW / 810 SB /

5-32

810 SM / 810 SRM / 810 AZ

Standard versions

MarCator 810 AU / 810 AX / 810 SV / 810 AG

5-34

Special versions

Digital Indicators (Long Range)

Overview

5-36

MarCator 1075 / 1080 / 1081

5-38

Standard versions with digital display

MarCator μ Max μ m XL

5-40

With tolerance function

MarCator 1086 / 1086 W / 1086 Z

5-42

With integrated tolerance functions

MarCator 1087 / 1087 / Z

5-46

With combined digital and analog display

MarCator 1088 / 1088 W

5-48

With background lit display

MarCator 1087 B

5-50

For 2-point inside measurement

Accessories for MarCator 1086 / 1087 / 1088

5-51

Contact Points and Accessories for Dial / Digital Indicators,

5-52

Mechanical / Digital Comparators & Probes

MarCator ANSI/AGD Dial Indicators

OVERVIEW

Dial Indicators Selection Guide

Grad	Range per Rev.	Total Range	Dial Style w/o Rev	Dial Style with Rev	Order number	
					w/o Rev Counter	with Rev Counter
Group 0						
<i>.0001"</i>	<i>.004"</i>	<i>.010"</i>	0-2-0	-	A1/2Q	
<i>.0001"</i>	<i>.010"</i>	<i>.025"</i>	0-5-0	-	A2I	
<i>.0005"</i>	<i>.020"</i>	<i>.050"</i>	0-10-0	-	A3Q	
<i>.001"</i>	<i>.040"</i>	<i>.100"</i>	0-20-0	-	A6Q	
.002 mm	.100	.250	0-5-0	-	N1/2O	
.005 mm	.500	1.25	0-25-0	-	N3I	
.010 mm	1.00	2.50	0-50-0	-	N6I	
Group 1						
<i>.0001"</i>	<i>.010"</i>	<i>.025"</i>	0-5-0	0-10	12I	12I-RC
<i>.00025"</i>	<i>.010"</i>	<i>.025"</i>	0-5-0	0-10	12Q	12Q-RC
<i>.00025"</i>	<i>.020"</i>	<i>.050"</i>	0-10-0	0-20	B3K	B3K-RC
<i>.0005"</i>	<i>.020"</i>	<i>.050"</i>	0-10-0	0-20	B3Q	B3Q-RC
<i>.0005"</i>	<i>.030"</i>	<i>.075"</i>	0-15-0	0-30	B5M	B5M-RC
<i>.0005"</i>	<i>.040"</i>	<i>.100"</i>	0-20-0	0-40	B6K	B6K-RC
<i>.0005"</i>	<i>.050"</i>	<i>.125"</i>	0-25-0	0-50	B7I	B7I-RC
<i>.001"</i>	<i>.020"</i>	<i>.050"</i>	0-10-0	0-20	B3W	B3W-RC
<i>.001"</i>	<i>.040"</i>	<i>.100"</i>	0-20-0	0-40	B6Q	B6Q-RC
<i>.001"</i>	<i>.050"</i>	<i>.125"</i>	0-25-0	0-50	B7O	B7O-RC
<i>.001"</i>	<i>.100"</i>	<i>.250"</i>	0-50-0	0-100	B8I	B8I-RC
.002 mm	.200	.500	0-10-0	0-20	O1I	O1I-RC
.005 mm	.500	1.25	0-25-0	0-50	O3I	O3I-RC
.010 mm	1.00	2.50	0-50-0	0-100	O6I	O6I-RC
.025 mm	2.50	6.25	0-125-0	0-250	O8I	O8I-RC
Group 2						
<i>.00005"</i>	<i>.004"</i>	<i>.010"</i>	0-2-0	0-4	C1/2K	C1/2K-RC
<i>.0001"</i>	<i>.008"</i>	<i>.020"</i>	0-4-0	0-8	C1K	C1K-RC
<i>.0001"</i>	<i>.010"</i>	<i>.025"</i>	0-5-0	0-10	2015781	2014761
<i>.00025"</i>	<i>.010"</i>	<i>.025"</i>	0-5-0	0-10	2015782	2014791
<i>.00025"</i>	<i>.020"</i>	<i>.050"</i>	0-10-0	0-20	2015783	2014808
<i>.0005"</i>	<i>.020"</i>	<i>.050"</i>	0-10-0	0-20	2015784	2014810
<i>.0005"</i>	<i>.030"</i>	<i>.075"</i>	0-15-0	0-30	2015786	2014811
<i>.0005"</i>	<i>.040"</i>	<i>.100"</i>	0-20-0	0-40	2015787	2014812
<i>.0005"</i>	<i>.050"</i>	<i>.125"</i>	0-25-0	0-50	2015790	2014814
<i>.001"</i>	<i>.020"</i>	<i>.050"</i>	0-10-0	0-20	2015785	2014809
<i>.001"</i>	<i>.040"</i>	<i>.100"</i>	0-20-0	0-40	2015789	2014813
<i>.001"</i>	<i>.050"</i>	<i>.125"</i>	0-25-0	0-50	2015791	2014815
<i>.001"</i>	<i>.100"</i>	<i>.250"</i>	0-50-0	0-100	2015792	2011049
.001 mm	.100	.250	0-5-0	0-10	P1/2I	P1/2I-RC
.002 mm	.200	.500	0-10-0	0-20	P1I	P1I-RC
.005 mm	.500	1.25	0-25-0	0-50	2015793	2014817
.010 mm	1.00	2.50	0-50-0	0-100	2015794	2014818
.020 mm	2.00	5.00	0-100-0	0-200	2015795	2014819
1 Rev						
<i>.0005"</i>	-	<i>.040"</i>	-	-	2014793	
<i>.001"</i>	-	<i>.080"</i>	-	-	2014792	
.010 mm	-	1.00	-	-	2014795	
.020 mm	-	2.00	-	-	2014794	
.010 mm	-	1.00	-	-	2014797	
.020 mm	-	2.00	-	-	2014796	

Grad	Range per Rev.	Total Range	Dial Style w/o Rev	Dial Style with Rev	Order number	
					w/o Rev Counter	with Rev Counter
Group 3						
<i>.0001"</i>	<i>.008"</i>	<i>.020"</i>	0-4-0	0-8	D1K	D1K-RC
<i>.0001"</i>	<i>.010"</i>	<i>.025"</i>	0-5-0	0-10	32I	32I-RC
<i>.00025"</i>	<i>.010"</i>	<i>.025"</i>	0-5-0	0-10	32Q	32Q-RC
<i>.00025"</i>	<i>.020"</i>	<i>.050"</i>	0-10-0	0-20	D3K	D3K-RC
<i>.00025"</i>	<i>.030"</i>	<i>.075"</i>	0-15-0	0-30	D5G	D5G-RC
<i>.0005"</i>	<i>.020"</i>	<i>.050"</i>	0-10-0	0-20	D3Q	D3Q-RC
<i>.0005"</i>	<i>.030"</i>	<i>.075"</i>	0-15-0	0-30	D5M	D5M-RC
<i>.0005"</i>	<i>.040"</i>	<i>.100"</i>	0-20-0	0-40	D6K	D6K-RC
<i>.0005"</i>	<i>.050"</i>	<i>.125"</i>	0-25-0	0-50	D7I	D7I-RC
<i>.001"</i>	<i>.020"</i>	<i>.050"</i>	0-10-0	0-20	D3W	D3W-RC
<i>.001"</i>	<i>.040"</i>	<i>.100"</i>	0-20-0	0-40	D6Q	D6Q-RC
<i>.001"</i>	<i>.050"</i>	<i>.125"</i>	0-25-0	0-50	D7O	D7O-RC
<i>.001"</i>	<i>.100"</i>	<i>.250"</i>	0-50-0	0-100	D8I	D8I-RC
.002 mm	.200	.500	0-10-0	0-20	Q1I	Q1I-RC
.005 mm	.500	1.25	0-25-0	0-50	Q3I	Q3I-RC
.010 mm	1.00	2.50	0-50-0	0-100	Q6I	Q6I-RC
.020 mm	2.00	5.00	0-100-0	0-200	Q8I	Q8I-RC
Group 4						
<i>.0001"</i>	<i>.008"</i>	<i>.020"</i>	0-4-0	0-8	E1K	E1K-RC
<i>.0001"</i>	<i>.010"</i>	<i>.025"</i>	0-5-0	0-10	42I	42I-RC
<i>.00025"</i>	<i>.020"</i>	<i>.050"</i>	0-10-0	0-20	E3K	E3K-RC
<i>.00025"</i>	<i>.030"</i>	<i>.075"</i>	0-15-0	0-30	E5G	E5G-RC
<i>.0005"</i>	<i>.020"</i>	<i>.050"</i>	0-10-0	0-20	E3Q	E3Q-RC
<i>.0005"</i>	<i>.030"</i>	<i>.075"</i>	0-15-0	0-30	E5M	E5M-RC
<i>.0005"</i>	<i>.050"</i>	<i>.125"</i>	0-25-0	0-50	E7I	E7I-RC
<i>.001"</i>	<i>.020"</i>	<i>.050"</i>	0-10-0	0-20	E3W	E3W-RC
<i>.001"</i>	<i>.050"</i>	<i>.125"</i>	0-25-0	0-50	E7O	E7O-RC
<i>.001"</i>	<i>.100"</i>	<i>.250"</i>	0-50-0	0-100	E8I	E8I-RC
.002 mm	.200	.500	0-10-0	0-20	R1I	R1I-RC
.005 mm	.500	1.25	0-25-0	0-50	R3I	R3I-RC
.010 mm	1.00	2.50	0-50-0	0-100	R6I	R6I-RC
.020 mm	2.00	5.00	0-100-0	0-200	R8I	R8I-RC
Long Range						
<i>.0001"</i>	<i>.010"</i>	<i>.500"</i>	–	0-10		42IQ
<i>.001"</i>	<i>.100"</i>	<i>.500"</i>	–	0-100		2014699
<i>.001"</i>	<i>.100"</i>	<i>1.00"</i>	–	0-100		2014698
<i>.001"</i>	<i>.100"</i>	<i>1.00"</i>	–	0-100		D8IS
<i>.001"</i>	<i>.100"</i>	<i>2.00"</i>	–	0-100		D8IT
<i>.001"</i>	<i>.100"</i>	<i>3.00"</i>	–	0-100		E8IU
<i>.010"</i>	<i>1.00"</i>	<i>1.00"</i>	–	0-1000		2014816
.010 mm	1.00	25.00	–	0-100		SP6IS
.010 mm	1.00	25.00	–	0-100		SQ6IS
.025 mm	2.50	50.00	–	0-25		Q8IT
.025 mm	2.50	75.00	–	0-25		R8IU

Dial Indicators per ANSI/AGD

Features

You get more with Mahr Federal Dial Indicators

- Proven for the most demanding applications
- Superior design and serviceability
- Unmatched customer and technical support
- Catalog and customized styles
- Full range of accessories to suit virtually every need
- Unit construction, removable movement . . . saves repair/cleaning time and maintenance costs
- Hardened gears and stainless steel racks provide lasting protection against indicator failure due to shock or wear
- Jeweled bearings resist friction, add to longer indicator life
- Skeletonized, hobbled gears for more sensitive response, superior indicator accuracy with minimal hysteresis error
- Soft-tinted dials (green, inch, or yellow, metric) minimize eye strain
- Special steel alloy, balanced dial hand affords no-shift, precise reading
- Controlled rack and pinion mesh eliminates slope for precise response and reading
- Smooth-adjusting bezels for easy setup
- Positive pressure pull-back spring . . . less maintenance
- Compliance with ANSI/AGD dimensional and accuracy specifications
- Many models employ stainless steel stem for added durability

How to Order

How to Order Your Dial Indicator and Accessories

1. Select the type of Indicator you require. Check the specialize types as well as regular ANSI/AGD models.
2. Choose the Model best suited to the magnification, range and viewing needs of your job.
3. Accessories. These are important because they greatly increase the speed, efficiency and convenience of obtaining desired results. A wide selection of Mahr Federal dial indicator accessories are shown in this catalog.
4. Options. You are not restricted to the normally furnished equipment mentioned above. A wide choice of optionally available points, backs or dial arrangements can be specified at little or no extra cost. We maintain the most extensive stock of indicators and gages for dimensional measurement available anywhere. Items which are in stock are normally shipped within five working days. If you need them sooner, inquire when ordering. We can often make next-day deliveries. Understandably, some of the items in this catalog are not always in stock or are special order items, which take a little longer to ship.

If you need help in determining what Indicators right for your application, just ask us. Contact Mahr Federal:

1-800-333-4243

One of our experienced professionals will give you courteous, professional advice that can save you time and money.

Replacement indicators

Although Mahr Federal dial indicators are known for their lifetime service, it is not uncommon to change an indicator back, contact point, dial or to even add an accessory to suit your latest application.

When ordering a replacement dial indicator for a specific application, always verify the configuration of the indicator. Ordering a replacement using the standard model number shown on your indicator may not provide you with the configuration or accessories you desire.



Dial Indicators per ANSI/AGD

Selecting a Dial Indicator

Since modern manufacturing involves a wide range of tolerances, choosing a dial indicator might be difficult, especially since the number of indicators available is so vast. The following guidelines were prepared to assist you in selecting the right model for your application.

Consider four characteristics when selecting a dial indicator:

- **Minimum Graduation Value** — value of the smallest graduations marked on the dial. From several different values available from Mahr Federal, select the one which is closest to 10% of the tolerance spread of the work you are measuring. This assures that the tolerance will span about ten divisions of the dial
- **Size** — represents the bezel diameter. Make your selection on the basis of space available for the indicator and the distance from which it will be viewed. The Indicator photograph shown on the first page of each ANSI/AGD Group is full scale. Simply place the page which illustrates the Indicator at the expected viewing distance, and choose the size that offers you the best readability and is the proper size for your fixture. Mahr Federal's "C" size bezels (ANSI/AGD Group 2), which have a diameter of 2-1/4", are the most popular.
- **Range per Revolution** — represents the distance the spindle travels with one complete revolution of the dial hand. From the dials available in the size and minimum graduation value you chose, select the range per revolution which allows the tolerance spread to occupy 1/10 to 1/4 of the dial.
- **Total Range** — the maximum distance over which the indicator spindle can travel. Usually, this represents 2-1/2 revolutions of the hand, which is adequate for most needs. Sometimes, however, this may not be adequate for your application and a special total range may be necessary.

If your tolerance spread is .006" ($\pm .003$ "), then, the most suitable minimum graduation value is .0005".

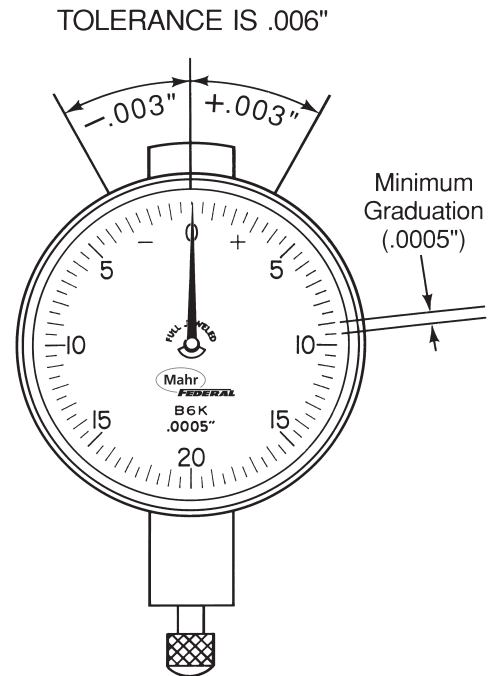

Your tolerance spread is .006". You have chosen an ANSI/AGD Group 2 (Mahr Federal "C" Size) dial with a minimum graduation value of .0005". Mahr Federal offers four indicator types in this size and minimum graduation value. Of these, type C5M has a range per revolution of .030" which is about midway between your tolerance extremes.

You selected a C5M indicator. Your total range, however, needs to be at least .200" so the spindle can clear the lip of your part. But, the longest range available in the C5M indicator you need is only .075". Special ranges up to .400" are available for this indicator type. Select the closest range for your application (for Model C5M, you would select .250").

If the range you need is not listed under the "Special Ranges" category, contact Mahr Federal. Chances are we can supply the range you need.

Copies of the current ANSI Standard for Dial Indicators (ANSI B89.1.1 0-1987) are available from:

The American Society of Mechanical Engineers
ASME Order Desk
22 Law Drive
Fairfield, NJ 07007
(973)882-1167

Dial Indicators per ANSI/AGD

Dial Types

1. Balanced (+) on right.

Normally furnished on all Group 0, 1, 3 and 4 ANSI/AGD indicators only, unless otherwise specified. Indicates an increasing value when contact is depressed as in comparison type O.D. snap and bench thickness gages.

Note: If Revolution Counter models are ordered, counter dial numbered counterclockwise.

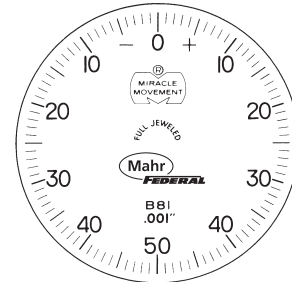

2. Balanced (+) on left.

Indicates decreasing values when contact is depressed as in comparison bore* and depth gages.

Note: With Revolution Counter models, counter dial numbered clockwise.

* Will vary as dictated by motion transfer design.

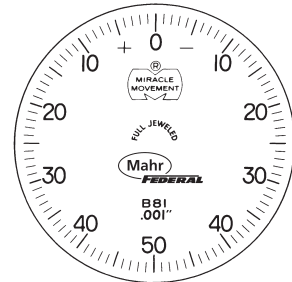

3. Continuous clockwise.

Normally furnished on Long and Extra Long Range Indicators, unless otherwise specified. Indicates an increasing value when contact is depressed as in direct-reading thickness gages.

Note: With Revolution Counter models, counter dial numbered counterclockwise.

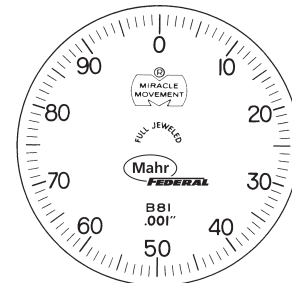

4. Continuous counterclockwise.

Indicates a decreasing value when contact is depressed as in direct reading slot, recess or hole depth measurements.

Note: If Revolution Counter models are ordered, counter dial numbered clockwise

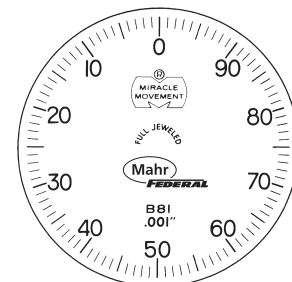

Dial Indicators per ANSI/AGD Group 0 - Mahr Federal Series A and N

Where available space prohibits the use of a larger dial indicator.



Technical Data

Mahr Federal Series A (inch)

Dial: approx. 1.250" dia. with soft-green tint

Measuring range	Graduation value	Dial style	Range per revolution	Accuracy	Order no.
.010"	.0001"	0-2-0	.004"	±.0001"	A1/2Q
.025"	.0001"	0-5-0	.010"	±.0001"	A2I
.050"	.0005"	0-10-0	.020"	±.0005"	A3Q
.100"	.001"	0-20-0	.040"	±.001"	A6Q

Mahr Federal Series N (Metric – mm)

Dial: approx. 32 mm dia. with soft-yellow tint

Measuring range	Graduation value	Dial style	Range per revolution	Accuracy	Order no.
0.250	0.002	0-5-0	0.100	±0.002 mm	N1/2Q
1.250	0.005	0-25-0	0.500	±0.005 mm	N3I
2.500	0.010	0-50-0	1.00	±0.010 mm	N6I

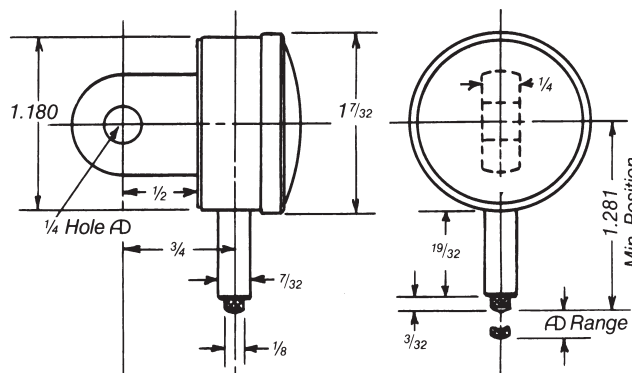

Backs can be rotated 90° and 180°

Dial Indicators per ANSI/AGD Group 0 - Mahr Federal Series A and N

Mahr Federal Series A

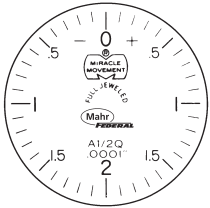

A1/2Q



A2I

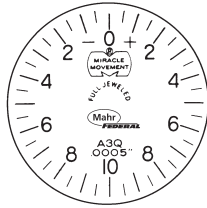

A3Q

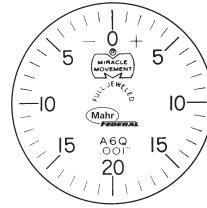

A6Q

- Normally furnished: balanced dial with + on right; centered vertical lug back; regular contact point, .09" radiused, .093" long.
- Optional dials: balanced with + on left; continuous clockwise; continuous counter-clockwise. Order by part number and specify dial style desired.

Mahr Federal Series N

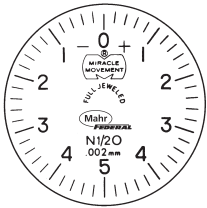

N1/2O

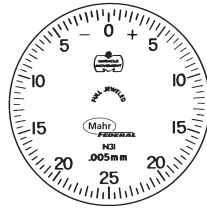

N3I

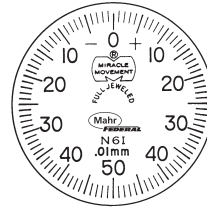

N6I

- For other dial styles or special requirements, call Mahr Federal.

Backs for ANSI Group 0 - Series A and N

Vertical (Centered) Lug Back is normally furnished and included in price of Indicator. Back can be rotated 90° for horizontal lug mounting.

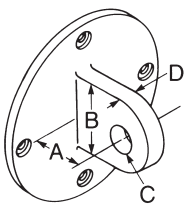

Vertical Lug (Centered)
BK-37

A B C D
1/2 11/16 1/4 1/4

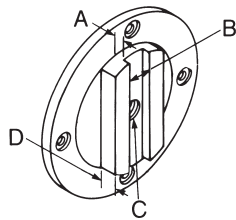

Adjustable
BK-45

A B C D
1/8 3/8 8-32 1/4

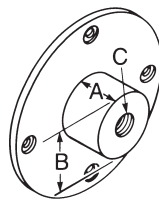

Screw Type
BK-88

A B C
1/2 11/16 1/4-28

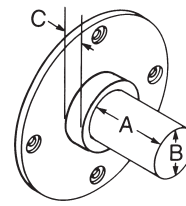

Post
BK-38

A B C
5/16 7/32 1/16

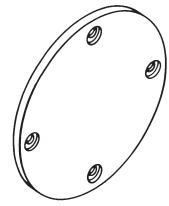

Flat
BK-32

Split Bushing, BU-112 Fits Stem (.218" I.D. x .375" O.D.), .500" long.



Points for ANSI Group 0 - Series A and N

Regular PT-43 normally furnished

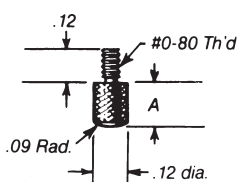

Dim. A Style

3/32"	PT-43
1/4"	PT-204
3/8"	PT-205
1/2"	PT-207
5/8"	PT-208
3/4"	PT-209
7/8"	PT-210
1"	PT-211

Taper PT-119

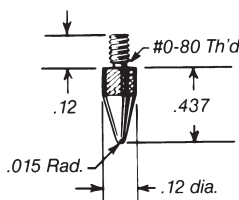

Button PT-118

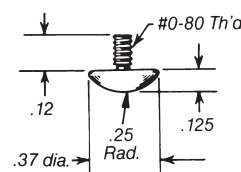

Flat AL-61

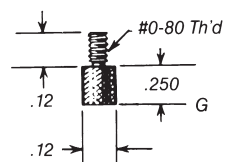

Dial Indicators per ANSI/AGD Group 1 - Mahr Federal Series B and O



Technical Data

Mahr Federal Series B (inch)

Dial: approx. 1.750" dia. with soft-green tint

Measuring range	Graduation value	Dial style w/o Rev Counter	Dial style with Rev Counter	Range per revolution	Accuracy	Order no. w/o Rev Counter	Order no. with Rev Counter
.025"	.0001"	0-5-0	0-10	.010"	±0001"	12I	12I-RC
.025"	.00025"	0-5-0	0-10	.010"	±00025"	12Q	12Q-RC
.050"	.00025"	0-10-0	0-20	.020"	±00025"	B3K	B3K-RC
.050"	.0005"	0-10-0	0-20	.020"	±0005"	B3Q	B3Q-RC
.075"	.0005"	0-15-0	0-30	.030"	±0005"	B5M	B5M-RC
.100"	.0005"	0-20-0	0-40	.040"	±0005"	B6K	B6K-RC
.125"	.0005"	0-25-0	0-50	.050"	±0005"	B7I	B7I-RC
.050"	.001"	0-10-0	0-20	.020"	±001"	B3W	B3W-RC
.100"	.001"	0-20-0	0-40	.040"	±001"	B6Q	B6Q-RC
.125"	.001"	0-25-0	0-50	.050"	±001"	B7O	B7O-RC
.250"	.001"	0-50-0	0-100	.100"	±001"	B8I	B8I-RC

Mahr Federal Series O (Metric, mm)

Dial: approx. 45 mm dia. with yellow tint

Measuring range	Graduation value	Dial style w/o Rev Counter	Dial style with Rev Counter	Range per revolution	Accuracy	Order no. w/o Rev Counter	Order no. with Rev Counter
0.500	0.002	0-10-0	0-20	0.200	±0.004	O1I	O1I-RC
1.250	0.005	0-25-0	0-50	0.500	±0.005	O3I	O3I-RC
2.500	0.010	0-50-0	0-100	1.000	±0.010	O6I	O6I-RC
6.250	0.025	0-125-0	0-250	2.500	±0.025	O8I	O8I-RC

Dimensions

ANSI / AGD Group	Mahr Federal Styles	A mm/inch	B mm/inch	C mm/inch	D mm/inch	E mm/inch
1	B/O	42.86/ 1.688"	41.28/ 1.625"	38.10/ 1.5"	15.88/ .625"	8.73/ .344"
2	C/P	57.15/ 2.25"	50.80/ 2"	52.39/ 2.063"	18.26/ .719"	8.73/ .344"

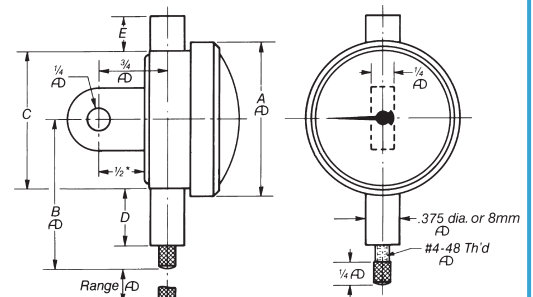

These indicators are normally furnished with continuous dial (with R.C.) or + on right balance dial (w/o R.C.), lug back and .18" by .250" long contact.

*except E size: .425

Dial Indicators per ANSI/AGD Group 2 - Mahr Federal Series C and P



Ordering Information

In addition to the information provided below, see pages 5-4 & 5-5 for complete instructions on ordering your dial indicators and accessories.

www.mahr.com

Technical Data

Mahr Federal Series C (inch)

Dial: approx. 2.250" dia. with soft-green tint

Measuring range	Graduation value	Dial style w/o Rev Counter	Dial style with Rev Counter	Range per revolution	Accuracy	Order no. w/o Rev Counter	Order no. with Rev Counter	OLD Order no.
.020"	.0001"	0-4-0	0-8	.008"	±.0001"	C1K	C1K-RC	C1K
.025"	.0001"	0-5-0	0-10	.010"	±.0001"	2015781	2014761	C2I/22I
.025"	.00025"	0-5-0	0-10	.010"	±.00025"	2015782	2014791	C2Q/22Q
.050"	.00025"	0-10-0	0-20	.020"	±.00025"	2015783	2014808	C3K/23K
.050"	.0005"	0-10-0	0-20	.020"	±.0005"	2015784	2014810	C3Q/23Q
.075"	.0005"	0-15-0	0-30	.030"	±.0005"	2015786	2014811	C5M/25M
.100"	.0005"	0-20-0	0-40	.040"	±.0005"	2015787	2014812	C6K/26K
.125"	.0005"	0-25-0	0-50	.050"	±.0005"	2015790	2014814	C7I/27I
.050"	.001"	0-10-0	0-20	.020"	±.001"	2015785	2014809	C3W/23W
.100"	.001"	0-20-0	0-40	.040"	±.001"	2015789	2014813	C6Q/26Q
.125"	.001"	0-25-0	0-50	.050"	±.001"	2015791	2014815	C7O/27O
.250"	.001"	0-50-0	0-100	.100"	±.001"	2015792	2011049	C8I/28IN

Super Sensitive Type (Inch)

.010"	.00005"	0-2-0	0-4	.004"	±.0001"	C1/2K	C1/2K-RC	C1/2K
-------	---------	-------	-----	-------	---------	-------	----------	-------

Mahr Federal Series P (Metric, mm)

Dial: approx. 57 mm dia. with soft-yellow tint

Measuring range	Graduation value	Dial style w/o Rev Counter	Dial style with Rev Counter	Range per revolution	Accuracy	Order no. w/o Rev Counter	Order no. with Rev Counter	OLD Order no.
0.500	0.002	0-10-0	0-20	0.200	±0.004	P11	P11-RC	P11/21IN
1.250	0.005	0-25-0	0-50	0.500	±0.005	2015793	2014817	P3I/23I
2.500	0.010	0-50-0	0-100	1.000	±0.010	2015794	2014818	P6I/26I
5.000	0.020	0-100-0	0-200	2.000	±0.020	2015795	2014819	P8I/28IM

Super Sensitive Type (Metric – mm)

0.250	0.001	0-5-0	0-10	0.100	±0.002	P1/2I	P1/2I-RC	P1/2I
-------	-------	-------	------	-------	--------	-------	----------	-------

These indicators are normally furnished with continuous dial (with R.C.) or + on right balance dial (w/o R.C.), lug back, .18" by .250" long contact and tolerance hands*.

* tolerance hands not supplied on C1K, C1/2K, P1I & P1/2I.

Accessories

- Contact Points - see page 5-27 and 5-22
- Backs and Mounting Brackets - see pages 5-21 and 5-22
- Accessories - see pages 5-23 and 5-24

Dial Indicators per ANSI/AGD Group 3 - Mahr Federal Series D and Q

Recommended for larger gages and greater visibility.



Ordering Information

In addition to the information provided below, see pages 5-4 & 5-5 for complete instructions on ordering your dial indicators and accessories.

www.mahr.com

Technical Data

Mahr Federal Series D (inch)

Dial: approx. 2.750" dia. with soft-green tint

Measuring range	Graduation value	Dial style w/o Rev Counter	Dial style with Rev Counter	Range per revolution	Accuracy	Order no. w/o Rev Counter	Order no. with Rev Counter
.020"	.0001"	0-4-0	0-8	.008"	±0001"	D1K	D1K-RC
.025"	.0001"	0-5-0	0-10	.010"	±0001"	32I	32I-RC
.025"	.00025"	0-5-0	0-10	.010"	±00025"	32Q	32Q-RC
.050"	.00025"	0-10-0	0-20	.020"	±00025"	D3K	D3K-RC
.075"	.00025"	0-15-0	0-30	.030"	±00025"	D5G	D5G-RC
.050"	.0005"	0-10-0	0-20	.020"	±0005"	D3Q	D3Q-RC
.075"	.0005"	0-15-0	0-30	.030"	±0005"	D5M	D5M-RC
.100"	.0005"	0-20-0	0-40	.040"	±0005"	D6K	D6K-RC
.125"	.0005"	0-25-0	0-50	.050"	±0005"	D7I	D7I-RC
.050"	.001"	0-10-0	0-20	.020"	±001"	D3W	D3W-RC
.100"	.001"	0-20-0	0-40	.040"	±001"	D6Q	D6Q-RC
.125"	.001"	0-25-0	0-50	.050"	±001"	D7O	D7O-RC
.250"	.001"	0-50-0	0-100	.100"	±001"	D8I	D8I-RC

Mahr Federal Series Q (Metric – mm)

Dial: approx. 70 mm dia. with soft-yellow tint

Measuring range	Graduation value	Dial style w/o Rev Counter	Dial style with Rev Counter	Range per revolution	Accuracy	Order no. w/o Rev Counter	Order no. with Rev Counter
0.500	0.002	0-10-0	0-20	0.200	±0.004	Q1I	Q1I-RC
1.250	0.005	0-25-0	0-50	0.500	±0.005	Q3I	Q3I-RC
2.500	0.010	0-50-0	0-100	1.000	±0.020	Q6I	Q6I-RC
5.000	0.020	0-100-0	0-200	2.000	±0.020	Q8I	Q8I-RC

These indicators are normally furnished with continuous dial (with R.C.) or + on right balance dial (w/o R.C.), lug back, and .18" by .250" long contact.

Accessories

- Contact Points - see pages 5-27 and 5-22
- Backs and Mounting Brackets - see pages 5-21 and 5-22
- Accessories - see pages 5-23 and 5-24

Dial Indicators per ANSI/AGD Group 4 - Mahr Federal Series E and R



Technical Data

Mahr Federal Series E (inch)

Dial: approx. 3.625" dia. with soft-green tint

Measuring range	Graduation value	Dial style w/o Rev Counter	Dial style with Rev Counter	Range per revolution	Accuracy	Order no. w/o Rev Counter	Order no. with Rev Counter
.020"	.0001"	0-4-0	0-8	.008"	±.0001"	E1K	E1K-RC
.025"	.0001"	0-5-0	0-10	.010"	±.0001"	42I	42I-RC
.050"	.00025"	0-10-0	0-20	.020"	±.00025"	E3K	E3K-RC
.075"	.00025"	0-15-0	0-30	.030"	±.00025"	E5G	E5G-RC
.050"	.0005"	0-10-0	0-20	.020"	±.0005"	E3Q	E3Q-RC
.075"	.0005"	0-15-0	0-30	.030"	±.0005"	E5M	E5M-RC
.125"	.0005"	0-25-0	0-50	.050"	±.0005"	E7I	E7I-RC
.050"	.001"	0-10-0	0-20	.020"	±.001"	E3W	E3W-RC
.125"	.001"	0-25-0	0-50	.050"	±.001"	E7O	E7O-RC
.250"	.001"	0-50-0	0-100	.100"	±.001"	E8I	E8I-RC

Mahr Federal Series R (Metric, mm)

Dial: approx. 92 mm dia. with yellow tint

Measuring range	Graduation value	Dial style w/o Rev Counter	Dial style with Rev Counter	Range per revolution	Accuracy	Order no. w/o Rev Counter	Order no. with Rev Counter
0.500	0.002	0-10-0	0-20	0.200	±0.004	R1I	R1I-RC
1.250	0.005	0-25-0	0-50	0.500	±0.005	R3I	R3I-RC
2.500	0.010	0-50-0	0-100	1.000	±0.010	R6I	R6I-RC
5.000	0.020	0-100-0	0-200	2.000	±0.020	R8I	R8I-RC

Dimensions

ANSI / AGD Group	Mahr Federal Styles	A mm/inch	B mm/inch	C mm/inch	D mm/inch	E mm/inch
3	D/Q	69.85/ 2.75"	53.98/ 2.125"	65.09/ 2.563"	15.88/ .625"	8.73/ .344"
4	E/R	92.08/ 3.625"	65.09/ 2.563"	87.31/ 3.438"	15.88/ .625"	8.73/ .344"

These indicators are normally furnished with continuous dial (with R.C.) or + on right balance dial (w/o R.C.), lug back and .18" by .250" long contact.

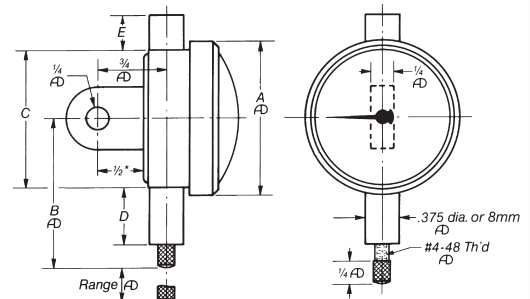

Easy Reading, Single Revolution Dial Indicator



Easy reading

A practical solution for inspectors and machine operators who need to eliminate the potential for indicator misreadings. No matter how far out of tolerance a part may be, the needle of a one revolution indicator will always stay in the red, non-read zone – no passing zero again – no reading errors.

- No limited contact travel
- Shockproof "Following Movement" always keeps the hand within a single revolution
- Alternate contact points, backs and other accessories are optionally available
- Metric dials are yellow
- One-piece case design
- Inserted precision bearings
- Available in ANSI/AGD Group 2 size

Technical Data

Measuring range	Graduation value	Stem diameter	Model no.	Order no.
2 mm	0.02 mm	.375"	P1RN-200	2014794
1 mm	0.01 mm	.375"	P1RN-100	2014795
2 mm	0.02 mm	8 mm	M1RN-200	2014796
1 mm	0.01 mm	8 mm	M1RN-100	2014797
.080"	.001"	.375"	C1RN-80	2014792
.040"	.0005"	.375"	C1RN-40	2014793

High Performance, Dial Indicators per ANSI/AGD Group 2

Features

- A well thought-out design, the use of high-quality components and materials as well as the precision engineered mechanism guarantee the outstanding quality of these indicators.
- The concentric "Speed Read" pointer (on 1.0" and .500" models) allows easy and safe reading of this Dial Indicator
- Spindle and stem are made of resistant stainless steel. Supplied with: Lug Back and Tolerance Hands



2016005



2016002

Technical Data

Measuring Range	Graduation value	Stem diameter	Dial style	Range per Rev.	Rev. Counter	Order no.
.250"	.001"	.375"	0-100	.100"	Standard	2016005
.500"	.001"	.375"	0-100	.100"	Speed read	2016004
1.00"	.001"	.375"	0-100	.100"	Speed read	2016002

Accessories

- Contact Points - see page 5-27

Dial Styles for ANSI/AGD Groups 1 thru 4 Balanced Dials

Mahr Federal Series B thru E

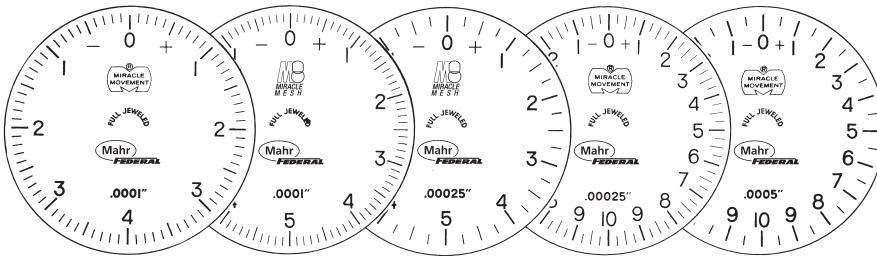

C1K	12I	12Q	B3K	B3Q
D1K	2015781	2015782	2015783	2015784
E1K	32I	32Q	D3K	D3Q
	42I		E3K	E3Q

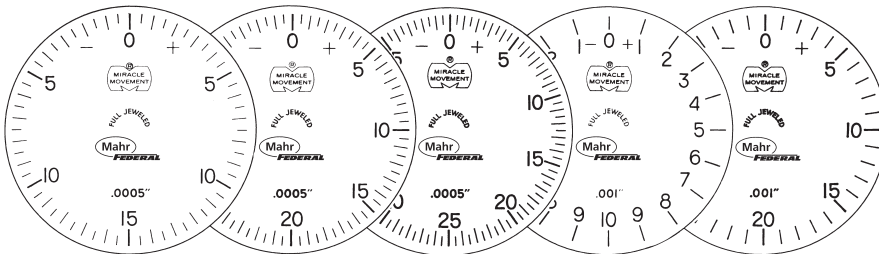

B5M	B6K	B7I	B3W	B6Q
2015786	2015787	2015790	2015785	2015789
D5M	D6K	D7I	D3W	D6Q
E5M		E7I	E3W	

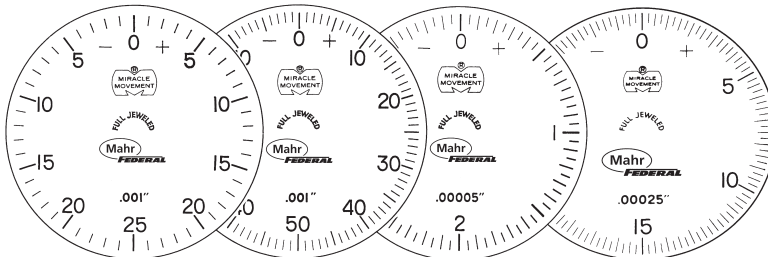

B7O	B8I	C1/2K	D5G
2015791	2015792		E5G
D7O	D8I		
E7O	E8I		

Mahr Federal Series O thru R

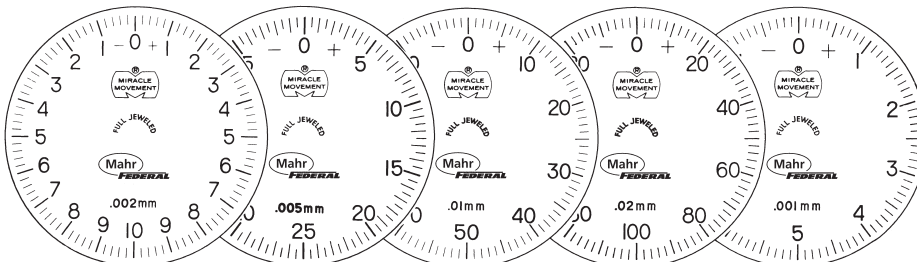

O1I	O3I	O6I	Q8I	P1/2I
P1I	2015793	2015794	2015795	
Q1I	Q3I	Q6I	R8I	
R1I	R3I	R6I		

Indicator O8I is not illustrated: Dial style is 0-125-0, minimum graduation is .025 mm

Features

- Normally furnished: dial as illustrated; centered vertical lug back; regular contact point, .18" radiused, 1/4" long.
- Optional Dials: balanced dial with + on left; continuous clockwise; continuous counter-clockwise. (Order by part number and specify dial style desired.)
- Revolution Counters available, please specify when ordering. Includes continuous dial unless otherwise specified.
- For other dial styles or special requirements - call Mahr Federal.
- Indicator dimensions are located on pages containing individual ANSI/AGD descriptions.

Accessories

- Contact Points - see page 5-27 and 5-22
- Backs and Mounting Brackets - see pages 5-21 and 5-22
- Accessories - see pages 5-23 and 5-24

Ordering Information

In addition to the information provided above, see pages 5-4 & 5-5 for complete instructions on ordering your dial indicators and accessories.

www.mahr.com

Long Range and Extra Long Range Indicators



Technical Data

Long Range/Extra Long Range (Inch)

Dial: soft-green tint

Measuring range	Graduation value	Dial style	Range per revolution	Accuracy	ANSI/AGD	Model no.	Order no.
.500"	.0001"	0-10	.010"	.0001"	4	42IQ	42IQ **
.500"	.001"	0-100	.100"	.001"	2	28IQN	2014699
1.000"	.001"	0-100	.100"	.001"	2	28ISN	2014698
1.000"	.001"	0-100	.100"	.001"	3	D8IS	D8IS
1.000"	.010"	0-1000	1.000"	.010"	2	29I	2014816
Extra Long Range							
2.000"	.001"	0-100	.100"	.001"***	3	D8IT	
3.000"	.001"	0-100	.100"	.001"***	4	E8IU	

* for first 2-1/2 revolutions only.

** hysteresis = 0.0003" for full range

*** for first 1 inch of travel.

Long Range/Extra Long Range (Metric)

Dial: yellow tint

Measuring range	Graduation value	Dial style	Range per revolution	Accuracy	ANSI/AGD	Model no.	Order no.
25.000	0.010	0-100	1.000	.020	2	SP6IS	
25.000	0.010	0-100	1.000	.020	3	SQ6IS	
Extra Long Range							
50.000	0.025	0-25	2.500	.025****	3	Q8IT	
75.000	0.025	0-25	2.500	.025****	4	R8IU	

**** for first 25 mm of travel.

Dial Styles for Long Range and Extra Long Range Indicators



281QN, 281SN & D81S

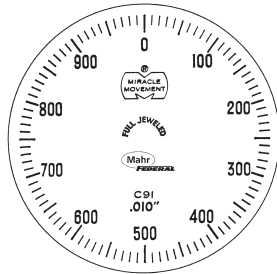

291

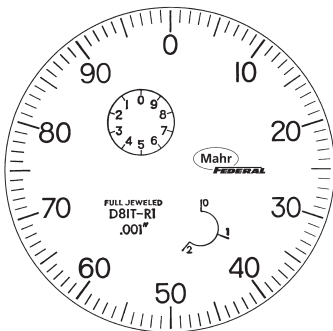

D81T & E81U

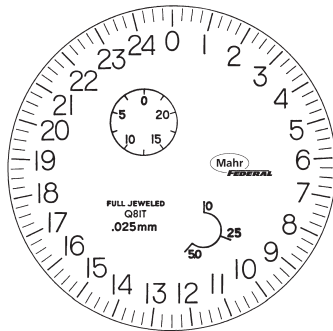

Q81T & R81U

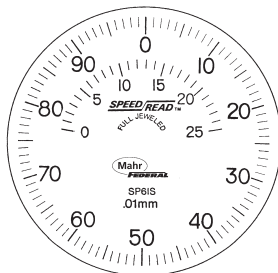

SP61S & SQ61S

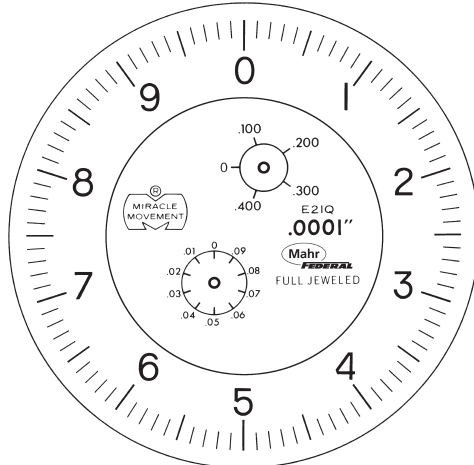

421Q

Features

- Normally furnished: continuous clockwise dial; centered vertical lug back; regular contact point, .18" radiused, .250" long.
- Long Range Models: include (1) revolution counter (except C91 without revolution counter). Extra Long Range Models: include (2) revolution counters.
- For other dial styles or special requirements - call Mahr Federal.
- Indicator dimensions are located on pages containing individual ANSI/AGD descriptions.

Accessories

- Contact Points - see page 5-27 and 5-22
- Backs and Mounting Brackets - see pages 5-21 and 5-22
- Accessories - see pages 5-23 and 5-24

Dial Indicator Modifications & Specials

Available to meet specific requirements.

- Special Ranges
- Restricted Hand Travel
- Special Dials
- High Temperature
- Special Contact Points
- 8 mm Stem Diameters Special Lengths
- Specified Contact Load
- Counter-clockwise Movement
- Special Stem Lengths
- Push-Down Action
- Special Ratio Movement
- Threaded Stems

Ordering Information

In addition to the information provided above, see pages 5-4 & 5-5 for complete instructions on ordering your dial indicators and accessories.

www.mahr.com

Series WC and WP Wetproof Dial Indicators

Splashproof protection from coolant, oil, or other contaminant's.



Technical Data

Series WC and WP Wetproof Dial Indicators (Inch)

Dial: approx. 2-1/4" dia. with soft-green tint

Measuring range	Graduation value	Dial style	Range per revolution	Accuracy	Order no.
.025"	.0001"	0-10	.010"	.0001"	W22I
.050"	.00025"	0-20	.020"	.00025"	WC3K
.050"	.0005"	0-20	.020"	.0005"	WC3Q
.075"	.0005"	0-30	.030"	.0005"	WC5M
.100"	.0005"	0-40	.040"	.0005"	WC6K
.125"	.0005"	0-50	.050"	.0005"	WC7I
.250"	.001"	0-100	.100"	.001"	WC8I
1.000"	.001"	0-100	.100"	.001"	WC8IS

Series WC and WP Wetproof Dial Indicators (Metric)

Dial: approx. 57 mm dia. with soft-yellow tint

Measuring range	Graduation value	Dial style	Range per revolution	Accuracy	Order no.
0.500	0.002	0-20	0.200	0.004	WP1I
1.250	0.005	0-50	0.500	0.005	WP3I
2.500	0.010	0-100	1.000	0.010	WP6I

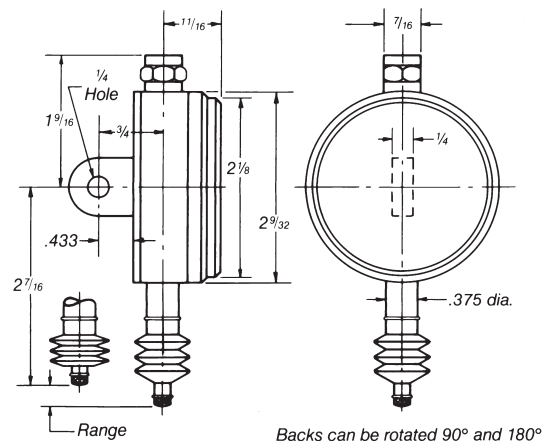

Dial Styles for WC and WP Wetproof Dial Indicators

Series WC indicators

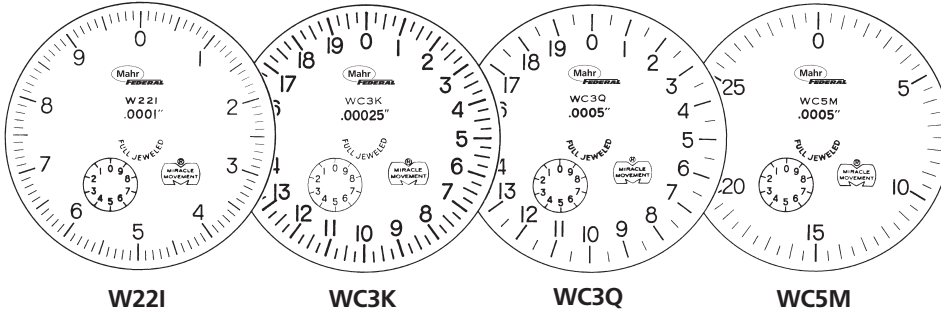

W221

WC3K

WC3Q

WC5M

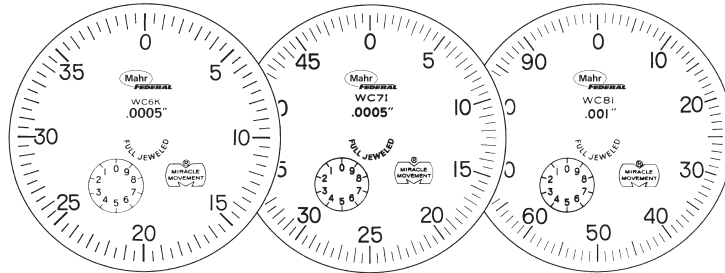

WC6K

WC7I

WC8I/WC8IS

Features

- Normally furnished: continuous clockwise dial with revolution counter; BK-63 centered vertical lug back; regular contact point, .18" radiused, .625" long
- Optional Dials: continuous counter-clockwise with revolution counter; balanced outer dial with + on right or left. Order by dial type and specify dial style desired.
- For other dial styles or special requirements - call Mahr Federal.

Series WP indicators

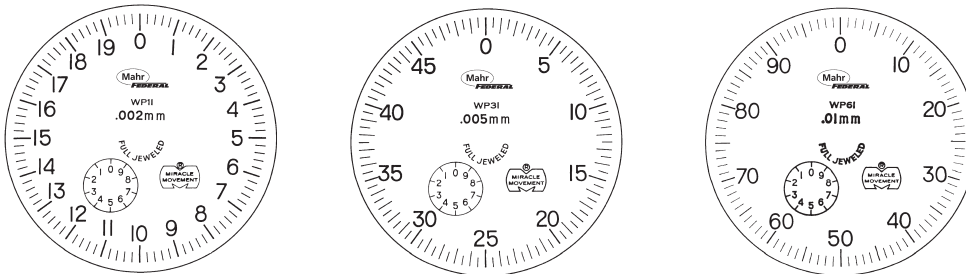

WP11

WP31

WP61

Accessories

- Contact Points - see page 5-27 and 5-22
- Accessories - see pages 5-23 and 5-24

Ordering Information

In addition to the information provided above, see pages 5-4 & 5-5 for complete instructions on ordering your dial indicators and accessories.

www.mahr.com

Backs for Wetproof Dial Indicators

Vertical (centered) lug back is normally furnished and included in price of indicator. Back can be rotated 90° for horizontal lug mounting.

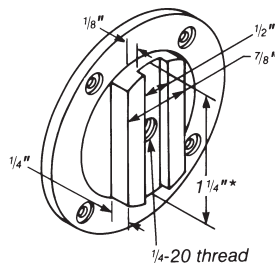

BK-68
Adjustable Back

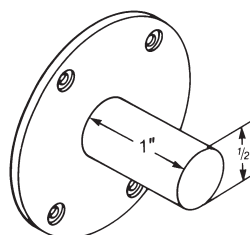

BK-90
Post Back

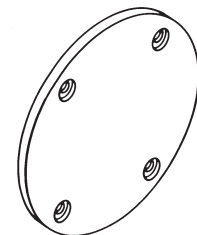

BK-97
Flat Back

Perpendicular Dial Indicators

Provides improved readability where other style indicators cannot be used.



Technical Data

Series F, G, J, V (Inch)

Dial: soft-green tint

Measuring range	Graduation value	Dial style	Range per revolution	Accuracy	Gear type	Dial Dia. (approx.)	Order no.
.008"	.0001"	0-4-0	.008"	.0001"	crown	2-1/4"	J1K
.040"	.0005"	0-20-0	.040"	.0005"	crown	2-1/4"	J6K
.100"	.0005"	0-12-0	.025"	.0005"	spiral	2-1/4"	G4O
.100"	.001"	0-50-0	.100"	.001"	crown	2-1/4"	J8I
.100"	.001"	0-50-0	.100"	.001"	crown	1-11/16"	V8I
.200"	.001"	0-50-0	.100"	.001"	spiral	1-23/32"	F8I
.200"	.001"	0-50-0	.100"	.001"	spiral	2-1/4"	G8I

Series I, W (Metric)

Dial: yellow tint

Measuring range	Graduation value	Dial style	Range per revolution	Accuracy	Gear type	Dial Dia. (approx.)	Order no.
0.200	0.002	0-10-0	0.200	0.002	crown	57	W1I
1.000	0.010	0-50-0	1.000	0.010	crown	57	W6I
2.500	0.025	0-125-0	2.500	0.025	crown	57	W8I
2.500	0.025	0-125-0	2.500	0.025	crown	43	I8I

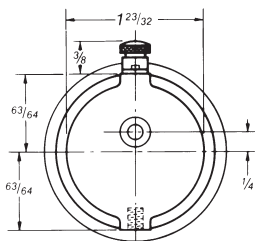

J & W Models

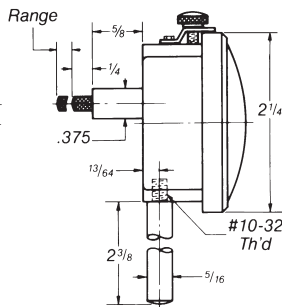

V & I Models

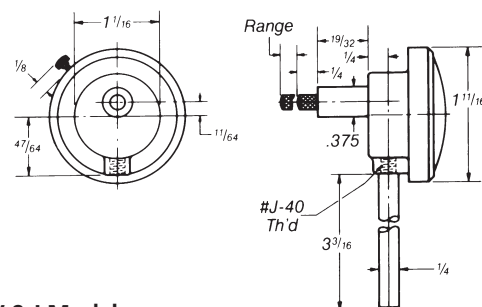

Dial Styles for Perpendicular Indicators

Series J, G, V, F



J1K

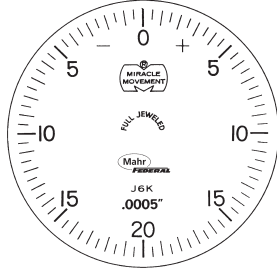

J6K

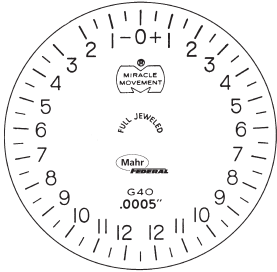

G40

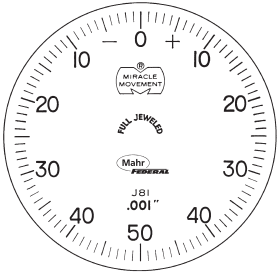

J81 & G81

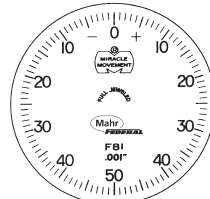

V81 & F81

Features

- Normally furnished: balanced dial with + on right; mounting rod (see dimension drawings); regular contact point, .18" radiused, .250" long.
- Threaded stem versions available as an option; AD-59 (.5622 long x .500" O.D. for "J & W" styles), 3/8-32 internally threaded bushings and AD-60 (.687" long x .500" O.D. for "G & F" Models) purchased separately. Bushings also available separately.
- For other dial styles or special requirements - call Mahr Federal.

Series W, I

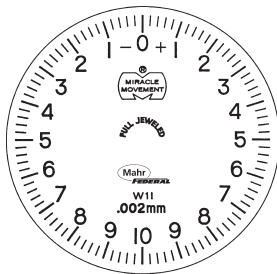

W11

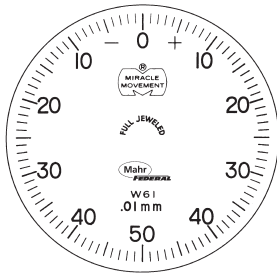

W61

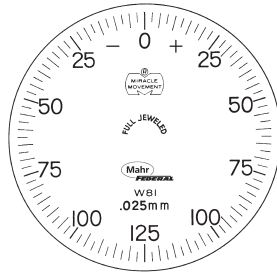

W81 & I81

Accessories

- Contact Points - see page 5-27 and 5-22
- Accessories - see pages 5-23 and 5-24

Ordering Information

In addition to the information provided above, see pages 5-4 & 5-5 for complete instructions on ordering your dial indicators and accessories.

www.mahr.com

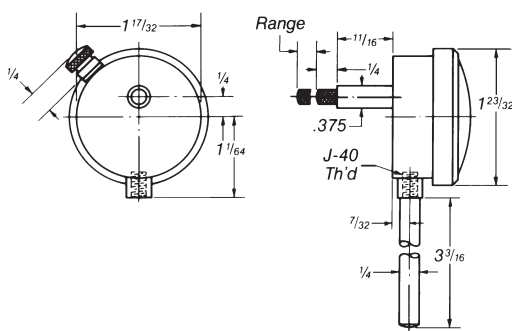

F81 Model

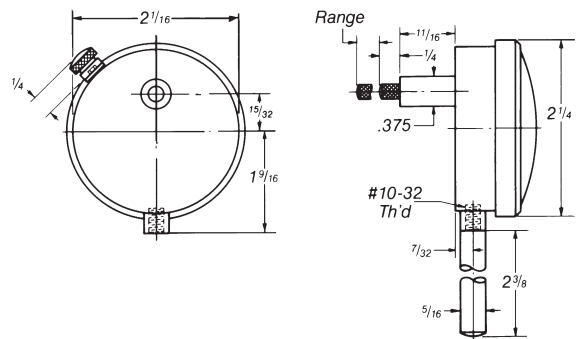

G Models

Backs for ANSI/AGD Group 1, 2, 3, and 4 Dial Indicators

Vertical Lug
(centered) normally furnished

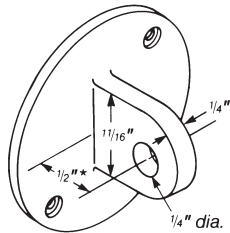

*27/64" for E/R size

Horizontal Lug
(centered)

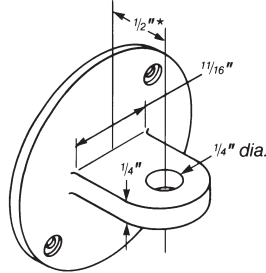

Post

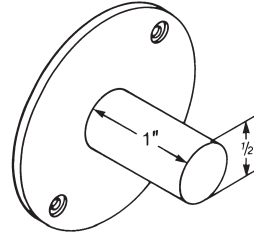

Vertical Lug
(offset) Left face of lug is on centerline of back

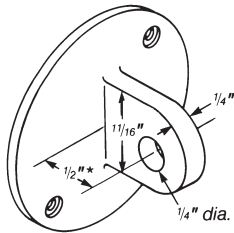

Screw Type

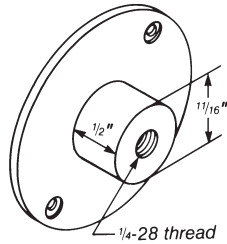

Adjustable

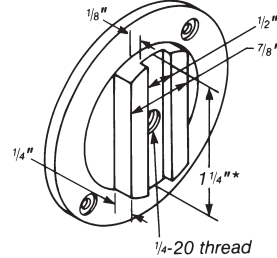

*7/8" for B/O size; no flats

Flat

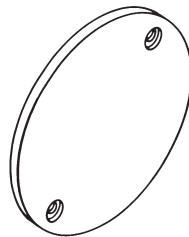

Features

- Backs shown are for ANSI/AGD Groups 1,2,3,4, Long Range and Extra Long Range Indicators. Backs for ANSI/AGD Group 0 Indicators - see page 5-8. Backs for Wetproof Indicators - see page 5-18.
- To order - specify Back Order Number (from table below).
- Backs for ANSI/AGD Group 1 (Series B/O) Indicators can be repositioned 180°. Backs for ANSI/AGD Group 4 (Series E/R) Indicators can be repositioned 90° and 180°.
- For Special Backs - call Mahr Federal.

Ordering Numbers

	ANSI/AGD			
	Group 1 Series B/O	Group 2 Series C/P	Group 3 Series D/Q	Group 4 Series E/R
Vertical Lug, Centered	BK-1600	BK-383	BK-431	BK-3
Vertical Lug, Offset	BK-1601	BK-2168	BK-545	BK-4
Horizontal Lug, Centered	BK-19	BK-400	BK-109	BK-3
Flat	BK-1660	BK-470	BK-473	BK-5
Post	BK-1634	BK-2093	BK-664	BK-17
Screw	BK-1661	BK-692	BK-177	BK-16
Adjustable	BK-1633	BK-531	BK-10	BK-18

Adjustable Mounting Brackets

Features

- Allows fast, positive indicator adjustments
- Ideal for permanent indicator mounting to fixtures
- Rack Back included with all Brackets
- Sizes for ANSI/AGD Groups 1 and 2

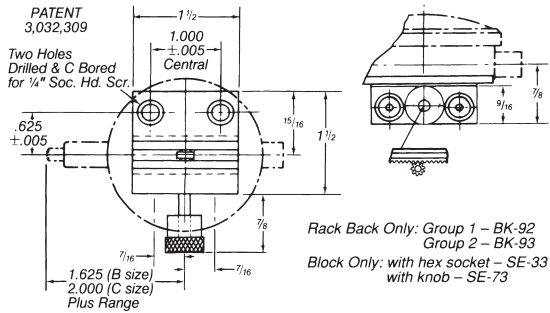

Order Numbers

Mahr Federal Indicator	Used with	Order no.
Group 1	hex socket adjust	AT-27
Group 1	adjusting knob	AT-115
Group 2	hex socket adjust	AT-28
Group 2	adjusting knob	AT-116

Universal Mounting Base

Features

- Allows mounting indicator to custom fixtures
- Uses lug back to mount indicator
- Accommodates all size indicators

Order no. BA-1051

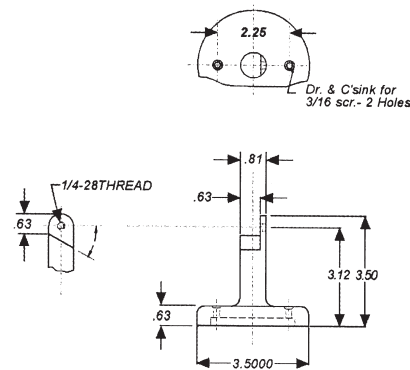

Added flexibility for your Mahr Federal Dial Indicators

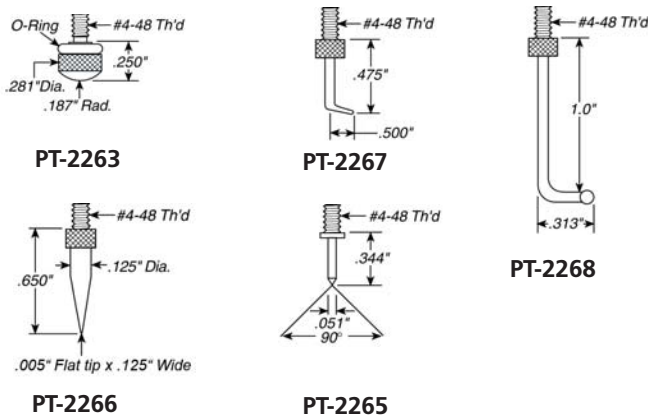

Description

Shock Absorbing Contact. "O" ring over threads provides a barrier between metal surface and stem, minimizing damage if point is pushed in with excessive force.

Order no.

PT-2263

Chisel Point Contact for checking small slots. Furnished with a small lock nut for positioning on the indicator.

PT-2266

Small Offset Point Contact. Small tip, .010" radius, permits checking narrow recesses. Furnished with a lock nut for indicator positioning.

PT-2267

Needle Contact for checking into small areas. Correct length for use as a replacement on Mahr Federal 65P-40 Depth Gage.

PT-2265

Right Angle Contact with a .093" diameter ball for checking hard-to-reach grooves. Right angle allows checking to bottom or to top of a groove when used with a push down action Indicator. Its 1" length makes it long enough to be used with Mahr Federal 75P-50 Series Depth Gages.

PT-2268

Contact Thread Adapter, Male M2.5 thread to 4-48 Female thread (.375" length)

AD-185

4-48 Male to M2.5 Female Threaded Adapter

2236519

Features

- Innovative Contact Points make your indicators more versatile.
- Minimize point damage with a shock absorbing contact, without the need for a cushion gear.
 - Needle point perfect for checking small areas – etchings, pits and more.
 - Chisel point easily adapts to small slots or screw heads.
 - Small offset point for narrow recesses – grooves, holes and under ledges.
 - Right angle point makes hard to reach grooves easily accessible.

Indicator Accessories

Weights

Used with ANSI/AGD type and long range indicators. Applies constant pressure throughout indicator range. To order specify requirement.



Protective Housing

For ANSI/AGD Group 2 indicators. Opens at rear so indicator can be mounted by its back. Mounts to indicator stem using a .687" O.D. bushing (not included). Order **HG-100** for Indicator models with ranges up to 6.35 mm /.250", **HG-101** for ranges of 6.35 mm /.250" to 25 mm /1". Recommended bushings: **BU-111** split bushing, or **AD-87** split collet. See next page.



Magnetic Maximum Hand

For ANSI/AGD Groups 2 and 3 indicators having plain dials. Accurately indicates maximum reading. Easy to reset. Order **2014804** (Group 2, snap-on bezel), **2011341** (Group 3, screw-on bezel).

Styles for Groups 1 and 4 indicators available on special order; consult Mahr Federal Customer Resource Center.



Range Limiting Caps

Used with ANSI/AGD type indicators. Adjustable thru 9.52 mm /.375" to limit range to any desired amount. Order **CS-123**.



Lifting Levers - CAM Type.

Used with ANSI/AGD type and long range indicators.



Use with Indicator Type	Order no. Left Hand	Order no. Right Hand
ANSI/AGD Group 1*	LR-46	LR-47**
ANSI/AGD Group 2*	LR-48	LR-49**
ANSI/AGD Group 3*	LR-50	LR-51**
ANSI/AGD Group 4*	LR-68	LR-69
Federal Models D8IT & Q8IT	LR-115	
Ox-Bow Lifting Lever	LR-40	

* Up to 25 mm /1" range

** Requires case to have Bezel Clamp on Left

Ox-Bow Lifting Lever - Type LR-40

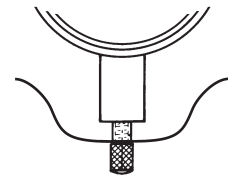

Tolerance Hands

Used with ANSI/AGD, long range and some Perpendicular indicators. Furnished integrally with split bezel. Easily replaces regular bezel.



Use with Indicator Type	Order no. Snap-on Bezel	Order no. Screw-type Bezel
ANSI/AGD Group 1	HD-128	HD-59
ANSI/AGD Group 2	BZ-2503	HD-57
ANSI/AGD Group 4		HD-53

Electronic Probe Adapter

Permits using electronic probes with many Mahr Federal dial indicators. Order **AD-138**.



Indicator Accessories

Hole Attachments

For ANSI/AGD type and perpendicular indicators with .375" diameter stems. For measuring internal surfaces. Order **AT-7293**, 47.50 mm/ 1.87" long **AT-7294**, 25 mm /1" long.



Split Collet

For .375" diameter stem indicators. Six-finger grip permits easy, secure indicator adjustment. Requires 1/2-32 threaded hole. O.D. is 17.45 mm/ .687". Can be used with protective housings, page 5-23. Order **AD-87**. For 1/2-32 tap, order **V-892**. 8 mm stem, order **AD-190**.



Brake Attachment

For ANSI/AGD indicators with .001" graduations. Requires indicator modification for assembly. Range limited to 6.35 mm/ .250" for Group 1 indicators; and to 12 mm/ .500" for Group 2 indicators. Order **AT-A-7** stem mount, **AT-81** dust cap mount.



Threaded Bushing

For ANSI/AGD indicators with 5/16-32 threaded stems (an available option from Mahr Federal). Permits conventional stem mounting of indicator in gages and fixtures. Order **AD-62**, .625" long, .500" O.D., 5/16-32 internal thread. Threaded bushings for perpendicular indicators, see page 5-19.



Auxiliary Plungers

For extending reach of all ANSI/AGD type and perpendicular indicators with .375" diameter stems and ranges up to 6.35 mm/ .250" range. Attaches to indicator stem by integral split collet. Body is 12 mm/ .500" O.D. Order **AT-25**, 57 mm/ 2.25" long, **AT-26**, 104 mm/ 4" long. Special lengths available. Replacement contact, **PT-184**, 8-32 thread.



Dust Guard

For ANSI/AGD perpendicular indicators with .375" diameter stems. Recommended for ranges of 7.62 mm/ .300" or less. Oil resistant to protect spindle and bushing from dust, mist and contaminant's. Order **GU-2**. For sealed indicators, see Wetproof models, page 5-17.



Split Bushings

Fits all ANSI/AGD type and perpendicular indicators. Permits safe, non-cramping stem mounting. Order **BU-94** without counterbore, **BU-80** with counterbore, .375" stem hole x .500" O.D., **BU-111** for use with protective housings (.375" stem hole x .687" O.D.), **BU-112** (.218" stem hole x .375" O.D.), **BU-197** with shoulder, **4310103** without shoulder. (8 mm stem hole x .375" O.D.)



Right Angle Attachments

For ANSI/AGD type and perpendicular indicators (.375" diameter stems). For making measurements at right angle to spindle movement. Order **A-9**, regular type with flat spring hinge; for ranges up to 3.05 mm/ .120". Replacement spring: **SP-56**. Order **AT-24**, long range type with pivot-type bearing; for ranges up to 9.50 mm/ .375".



Indicator Calibrator with Digital Readout

Features

Model 400B-50

- A precision, benchtop instrument, providing a convenient means for calibrating a wide variety of precision measuring instruments, including dial indicators, test indicators, AirProbes®, electronic gage heads, or any other device that magnifies the linear displacement of a contact point or measuring spindle – user selectable for either inch or metric units.
- Two calibration stations provide high magnification and long range in a single unit. Incorporated within the micrometer-style control is a rotary encoder which senses the amount of movement and displays the actual displacement on a digital readout.
- Digital readout consists of six high visibility, LED digits and operator-accessible controls for inch/metric units, range selection, zero reset, and polarity/direction.
- RS232 Output.



400B-50 Indicator Calibrator with Digital Readout

Technical Data

	Range	Minimum Graduation	Accuracy		
Inch					
High mag. station	.100"	.00001"	±20µ"	<ul style="list-style-type: none"> • Normally furnished: AM-178 Arm Assembly; AT-119 Mounting Clamp for .375" /9.5 mm dia. stems and probes; BU-112 Bushing (.218" I.D. to .375" O.D.). BU-197 Bushing (8 mm I.D. to .375" O.D.). AT-117 Adaptor for holding gage blocks. • Also Available: AT-120 Adaptor for test indicators with long contacts. AT-122 Adaptor for test indicators with short contacts. AT-121 Adaptor for AGD type indicators with lug backs. 	
Low mag. station	.500"	.00005"	±50µ"		
Metric (mm)					
High mag. station	2.5	0.0001	±0.4 µm		
Low mag. station	12.5	0.0005	±1.5 µm		
Display	6-digit, 7-segment LED				
Output	RS-232				
Power	115Vac/60Hz/220Vac/50Hz-switchable				
Dimensions Calibrator (approx.)	330 x 200 x 285 mm h /13 x 8 x 11.25" h				
Readout Unit	170 x 125 x 80 mm h /6.625 x 5 x 3.25" h				
Weight Calibrator (approx.)	11.8 kg /26 lb.				
Readout Unit	0.8 kg /1.75 lb				

Upgrade Kit

EKT-1204

A kit is available to upgrade Models 400B-5 and 400B-25 Universal Calibrators to digital readout units with RS-232 output. The kit consists of a precision micrometer style controller with a digital encoder, which replaces the mechanical head, plus a digital readout unit.

Dial Indicator Calibrator

Features

400B-3 and 400B-4 Shop-floor Calibrators

All too often we have blinders on and don't look at the whole picture on how a precision gage can do more than what's its intended to do. Take for example our Dial Indicator Calibrators 400B-3 & 400B-4. We look at it and know that its purpose is to calibrate AGD dial indicators right? But let's take it a step further! If we add the Universal centering support frame 800b (part number 4305893) from the test indicator section of our catalog and an 8mm to .375" bushing (part number 4310103) we now have the ability to calibrate test indicators having a .0001" / .002mm resolution giving the once only dial indicator calibrator a DUAL PURPOSE!

- For checking dial indicators (both ANSI/AGD and perpendicular styles) and other transducers.
- Large micrometer wheel has widely spaced graduations for easy setting and reading.
- Adjustable crosshair provides on-the-mark setting.
- Tungsten carbide anvil for maximum wear resistance.
- Indicator clamped in-line with micrometer spindle.



400B-3
Dial Indicator Calibrator



Technical Data

	Range	Minimum Graduation	Accuracy	Order no.
Metric (mm)	0-25	0.002	within 0.001*	400B-4
Inch	0-1.000"	.0001"	within .000050"	400B-3

* Accuracy calibration as specified in Federal Specification GGG-105B.

- Normally furnished:
BU-112 Bushing (.218" I.D. to .375" O.D.)
AD-58 Bushing (.275" I.D. to .375" O.D.)
BU-197 Bushing (8 mm I.D. to .375" O.D.)

Universal Calibrator

Features

Model 400B-5 and 400B-25

- Highest accuracy calibrator for precise monitoring of any gaging transducer— mechanical Indicator, air probe, or electronic gage head.
- Two calibrating stations: one for high magnification transducers and one for long range (up to 12.5 mm / .500").
- Easy to use: fine adjustment; large bi-directional reading micrometer head; carbide reference anvils; adjustable viewing angle.
- Furnished in a fitted wooden storage case.



400B-5
Universal Calibrator

Technical Data

	Range	Minimum Graduation	Accuracy	Order no.
Metric (mm)	2.5 12.5	0.0002 0.001	±0.4 μm ±0.8 μm	400B-25
Inch	.100" .500"	.000010" .000050"	±20 μm ±30 μm	400B-5

- Normally furnished:
AM-178 Arm Assembly;
AT-119 Mounting Clamp for 9.5 mm / .375" dia. stems and probes;
BU-112 Bushing (.218" I.D. to .375" O.D.);
BU-197 Bushing (8 mm I.D. to .375" O.D.);
AT-117 Adaptor for holding gage blocks.

- Also Available:
AT-120 Adaptor for test indicators with long contacts
AT-122 Adaptor for test indicators with short contacts
AT-121 Adaptor for AGD type Indicators with lug backs

Contact Points

Used with ANSI/AGD Groups 1,2,3,4 Long Range Wetproof Perpendicular and Maxµm® Indicators. Points for ANSI Group 0 Indicators - see page 5-8. For Special Points - call Mahr Federal. See pages 5-52 & 5-53 for additional Metric Contact Points.

Regular

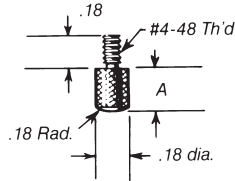

Hardened Steel (inch)

Dimension A	Order no.	Dimension A	Order no.
1/8"	PT-225	1-5/8"	PT-235
1/4"	PT-223*	1-3/4"	PT-241
3/8"	PT-563	1-7/8"	PT-100
1/2"	PT-14	2"	PT-51
5/8"	PT-564**	2-1/8"	PT-243
3/4"	PT-31	2-1/4"	PT-696
7/8"	PT-201	2-3/8"	PT-101
1"	PT-232	2-1/2"	PT-245
1-1/8"	PT-305	2-5/8"	PT-102
1-1/4"	PT-565	2-3/4"	PT-566
1-3/8"	PT-239	2-7/8"	PT-247
1-1/2"	PT-50	3"	PT-155

Hardened Steel (Metric***)

Dimension A	Order no.	Dimension A	Order no.
6 mm	EPT-1037-W1	15 mm	EPT-1037-W3
10 mm	EPT-1037-W2	20 mm	EPT-1037-W4
12 mm	EPT-1037-W6	25 mm	EPT-1037-W5

Tungsten Carbide

1/4" PT-35 Set of 8 Steel 1/8" to 1" PT-116

Diamond

1/4" PT-317 Set of 24 Steel 1/8" to 3" PT-115

* PT-223 normally furnished with all Indicators
 ** PT-564 normally furnished with all Wetproof Indicators
 *** All Metric Points have M2.5 thread

Tapered

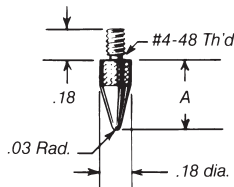

Hardened Steel (inch)

Dimension A	Order no.	Dimension A	Order no.
3/16"	PT-233	7/16"	PT-181
7/16"	PT-229	3/4"	PT-182
1"	PT-253	1"	PT-183
1-7/16"	PT-230		
2"	PT-231		

Tungsten Carbide (inch)

Flat End

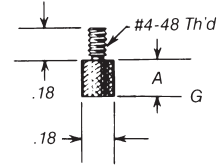

Hardened Steel (inch)

Dimension A	Order no.	Dimension A	Order no.
1/8"	AL-19	6 mm	EAL-1016-W1
1/4"	AL-673	10 mm	EAL-1016-W2
3/8"	AL-20	15 mm	EAL-1016-W3
1/2"	AL-21	20 mm	EAL-1016-W4
5/8"	AL-22	25 mm	EAL-1016-W5
3/4"	AL-23		
7/8"	AL-24		
1"	AL-25		

Tungsten Carbide

1/4" AL-51
 Set of 8 Steel
 1/8" to 1" AL-55

Button

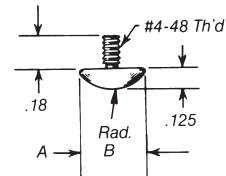

Hardened Steel (inch)

Dim. A	Dim. B	Order no.	Dim. A	Dim. B	Order no.
.375"	.250"	PT-227	.375"	.250"	PT-120
.500"	.375"	PT-619			

Tungsten Carbide

Wide Face

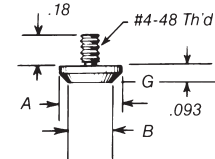

Hardened Steel (inch)

Dim. A	Dim. B	Order no.	Dim. A	Dim. B	Order no.
.356"	.250"	AL-502	9.04	6.35	EAL-1020-W1
.500"	.375"	AL-1510	12.7	9.5	EAL-1020-W2
.615"	.500"	AL-520	15.6	12.7	EAL-1020-W3
.731"	.625"	AL-44	18.6	15.9	EAL-1020-W4

Tungsten Carbide (inch)

.356" .250" AL-1730 Set of 8 Steel (Metric***)
 9.04 6.35 EAL-1021

Extra Wide Face



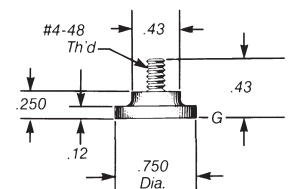

Hardened Steel





Order no. AL-291





MarCator Dial Indicators (DIN Style)

OVERVIEW







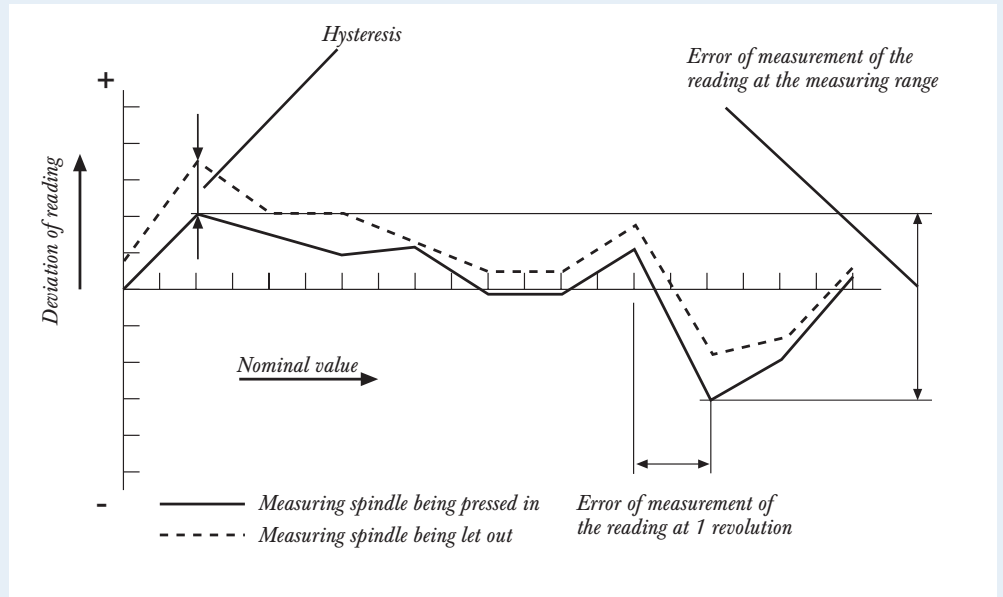

Precision Small Dial Indicators				
Model	803 A	805 A	803 S	803 SW
				
Range	3 mm	5 mm	3 mm	3 mm
Readings	0.01 mm	0.01 mm	0.01 mm	0.01 mm
Dial style	0-50	0-100	0-50	0-50
Standard for metrological characteristics	DIN 878	DIN 878	DIN 878	DIN 878
<i>DIN EN ISO 463</i>				
Limit value for measurement error at the reading	Messbereich	10 μm	12 μm	10 μm
	1 revolution	9 μm	9 μm	9 μm
	1/2 revolution	8 μm	8 μm	8 μm
	1/10 revolution	5 μm	5 μm	5 μm
Limit value for Repeatability	3 μm	3 μm	3 μm	3 μm
Limit value for Hysteresis	3 μm	3 μm	3 μm	3 μm
Shockproof			●	●
Measuring force	0.7 - 1.1 N	0.7 - 1.1 N	0.7 - 1.1 N	0.7 - 1.7 N
Order no.	4324050	4324060	4324000	4326000

Precision Dial Indicators				
Model	810 A	810 AT	810 S	810 SW
				
Range	10 mm	10 mm	10 mm	10 mm
Readings	0.01	0.01	0.01	0.01
Dial style	0-100	0-100	0-100	0-100
Standard for metrological characteristics	DIN 878	DIN 878	DIN 878	DIN 878
<i>DIN EN ISO 463</i>				
Limit value for measurement error at the reading	Messbereich	15 μm	15 μm	15 μm
	1 revolution	10 μm	10 μm	10 μm
	1/2 revolution	9 μm	9 μm	9 μm
	1/10 revolution	5 μm	5 μm	5 μm
Limit value for Repeatability	3 μm	3 μm	3 μm	3 μm
Limit value for Hysteresis	3 μm	3 μm	3 μm	3 μm
Shockproof			●	●
Measuring force	0.7 - 1.3 N	0.7 - 1.3 N	0.7 - 1.3 N	0.7 - 1.6 N
Order no.	4311050	4311060	4311000	4315000

803 SB	803 AZ
	
0.4 mm (±0.2)	.120"
0.01 mm	.0005"
0-20-0	0-20
DIN 878	Factory standard
9 μm	.0004"
8 μm	
5 μm	.0002"
3 μm	.00012"
3 μm	.00012"
●	
0.9 - 1.1 N	0.7 - 1.1 N
4324250	4324900

Metrological characteristics



810 SB	810 SM	810 SRM	810 AZ	810 AU	810 AX	810 AG	810 SV
							
0.8 mm (±0.4)	1 mm	5 mm	.400"	10 mm	10 mm	10 mm	40 mm
0.01	0.001	0.001	.0005"	0.01	0.1	0.01	0.01
0-40-0	0-100	0-100	0-45	100-0	0-10	0-100	0-100
DIN 878	Factory standard	Factory standard	Factory standard	Factory standard	Factory standard	Factory standard	Factory standard
7 μm	4 μm	10 μm	.0005"	15 μm	50 μm	17 μm	25 μm
6 μm	3 μm	7 μm		10 μm	50 μm	15 μm	15 μm
5 μm	2 μm	3 μm		9 μm	30 μm	10 μm	10 μm
3 μm	1 μm	2 μm	.0002"	5 μm	15 μm	5 μm	5 μm
3 μm	1.5 μm	3 μm	.00012"	5 μm	15 μm	3 μm	3 μm
3 μm	1.5 μm	3 μm	.00012"	5 μm	15 μm	5 μm	6 μm
●	●	●					●
0.7 - 1.1 N	1.3 - 1.8 N	1.2 - 1.7 N	0.9 - 1.5 N	1.0 - 1.8 N	0.7 - 1.3 N	1.3 - 2.2 N	0.8 - 1.8 N
4317000	4311070	4311080	4311900	4329050	4331000	4322000	4321000

Precision Small Dial Indicators 803 / 805 DIN style

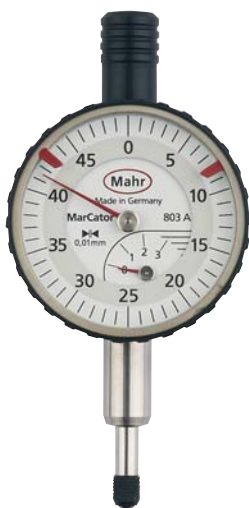

803 A

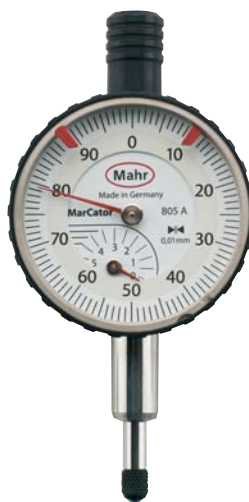

805 A



SHOCK
PROOF

803 S

Features

Small Dial Indicator 803 A

Standard version

- High precision gears and pinions
- Lifter protection cap on the upper end of the measuring spindle
- Adjustable tolerance markers
- Chrome-plated housing

Small Dial Indicator 805 A

Standard version

- High precision gears and pinions
- Lifter protection cap on the upper end of the measuring spindle
- Adjustable tolerance markers
- Chrome-plated housing

Small Dial Indicator 803 S

Shockproof version

- High precision gears and pinions
- Lifter protection cap on the upper end of the measuring spindle
- Adjustable tolerance markers
- Chrome-plated housing

All indicators are delivered in plastic case

Technical Data

	Range	Readings	Dial face dia.	Overtravel	Mounting shank dia.	Measuring force	Accuracy	Order no.
	mm	mm	mm	mm	mm	N	DIN 878	
803 A	3	0.01	34	0.1	8h6	0.7 - 1.1	●	4324050
805 A	5	0.01	34	0.1	8h6	0.7 - 1.1	●	4324060
803 S	3	0.01	34	0.1	8h6	0.7 - 1.1	●	4324000
803 SW	3	0.01	34	0.1	8h6	0.7 - 1.7	●	4326000
803 SB	0.4 (±0.2)	0.01	34	4.5	8h6	0.9 - 1.1	●	4324250
803 AZ	.120"	.0005"	1.4"	.008"	8h6	0.7 - 1.1		4324900

Precision Small Dial Indicators 803 / 805 DIN style



Features

Small Dial Indicator 803 SW

Waterproof and oil proof

Design features identical to 803 S, with the following exceptions:

- Hermetically sealed upper protective measuring spindle cap as well as bezel and transparent dial cover; sealed with O-rings
- Measuring spindle sealed with rubber sleeve, thus preventing contamination by liquids and impurities

Small Dial Indicator 803 SB

with limited measuring range

Design features identical to 803 S, with the following exceptions:

- Limited measuring range (0.4 mm) for error-free readings
- Large overtravel (ca. 4.5 mm), for easier insertion of test items in measuring devices
- Hermetically sealed upper protective measuring spindle cap

Small Dial Indicator 803 AZ

Inch version

Design features identical to 803 A, with the following exception:

- The scope of supply includes an Adapter Bush 940 for adapting mounting shank 8h6 mm to inch bore .375"

Dimensions according to DIN EN ISO 463

mm	a	b	c	d	e	f	g
803 A	∅ 40	20.6	6.8	∅ 37	83	15.5	8
805 A	∅ 40	20.6	6.8	∅ 37	83	15.5	8
803 S	∅ 40	20.6	6.8	∅ 37	80	15	5.5
803 SW	∅ 44	21.6	7.1	∅ 37	86	15	11
803 SB	∅ 40	20.6	6.8	∅ 37	83	15.5	8
803 AZ	∅ 40	20.6	6.8	∅ 37	83	15.5	8

Accessories

	Order no.	
Adapter Bush for adapting mounting shank 8h6 mm to inch bore .375"	940	4310103
Splash Guard Cover for bezel dia. 40 mm	956	4373021
Mounting Lugs Bore perpendicular to mounting shank	966	4375020
Bore parallel to mounting shank	967	4375021

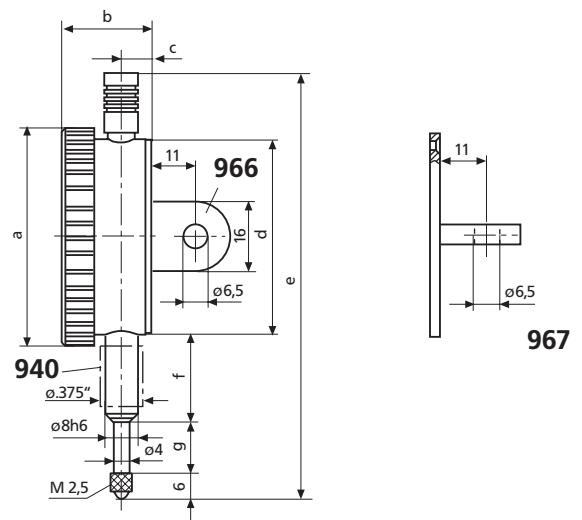

Precision Dial Indicators 810 DIN style

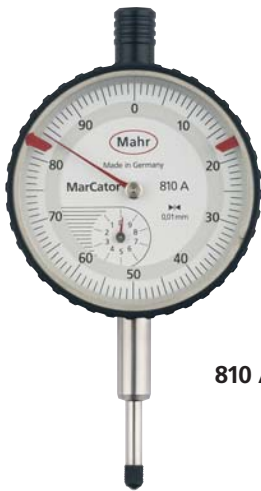

810 A

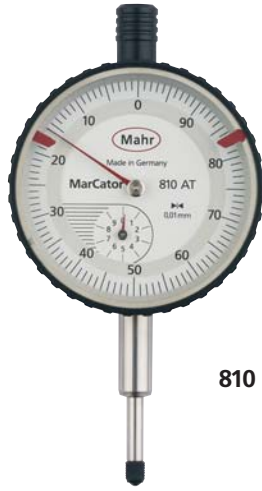

810 AT



810 S



810 SW

Features

Dial Indicator 810 A Standard version

- High precision gears and pinions
- Lifter protection cap on the upper end of the measuring spindle
- Adjustable tolerance markers
- Chrome-plated housing

Dial Indicator 810 AT for depth measurement

Design features identical to 810 A, with the following exception:

- Scale of the dial face is counter-clockwise

Dial Indicator 810 S Shockproof

- High precision gears and pinions
- Lifter protection cap on the upper end of the measuring spindle
- Adjustable tolerance markers
- Chrome-plated housing

Dial Indicator 810 SW Waterproof and oil proof

Design features identical to 810 S, with the following exceptions:

- Measuring spindle sealed with rubber sleeve, thus preventing contamination by liquids and impurities
- Hermetically sealed protective measuring spindle cap

All indicators are delivered in plastic case

Technical Data

	Range	Readings	Dial face dia.	Overtravel	Mounting shank dia.	Measuring force	Accuracy	Order no.
	mm	mm	mm	mm	mm	N	DIN 878	
810 A	10	0.01	50	0.1	8h6	0.7 - 1.3	●	4311050
810 AT	10	0.01	50	0.1	8h6	0.7 - 1.3	●	4311060
810 S	10	0.01	50	0.1	8h6	0.7 - 1.3	●	4311000
810 SW	10	0.01	50	0.1	8h6	0.7 - 1.6	●	4315000
810 SB	0.8 (±0.4)	0.01	50	9	8h6	0.7 - 1.1	●	4317000
810 SM	1	0.001	50	4	8h6	1.3 - 1.8		4311070
810 SRM	5	0.001	50	0.1	8h6	1.2 - 1.7		4311080
810 AZ	.400"	.0005"	2"	.004"	8h6	0.9 - 1.5		4311900

Accessories

	Order no.		Order no.
Adapter Bush for adapting mounting shank 8h6 mm to inch bore .375"	940	4310103	
Splash Guard Cover for bezel dia. 58 mm	955	4373020	
Mounting Lug			
Bore perpendicular to mounting shank	961		4375010
Bore parallel to mounting shank	962		4375011

Precision Dial Indicators 810 DIN style

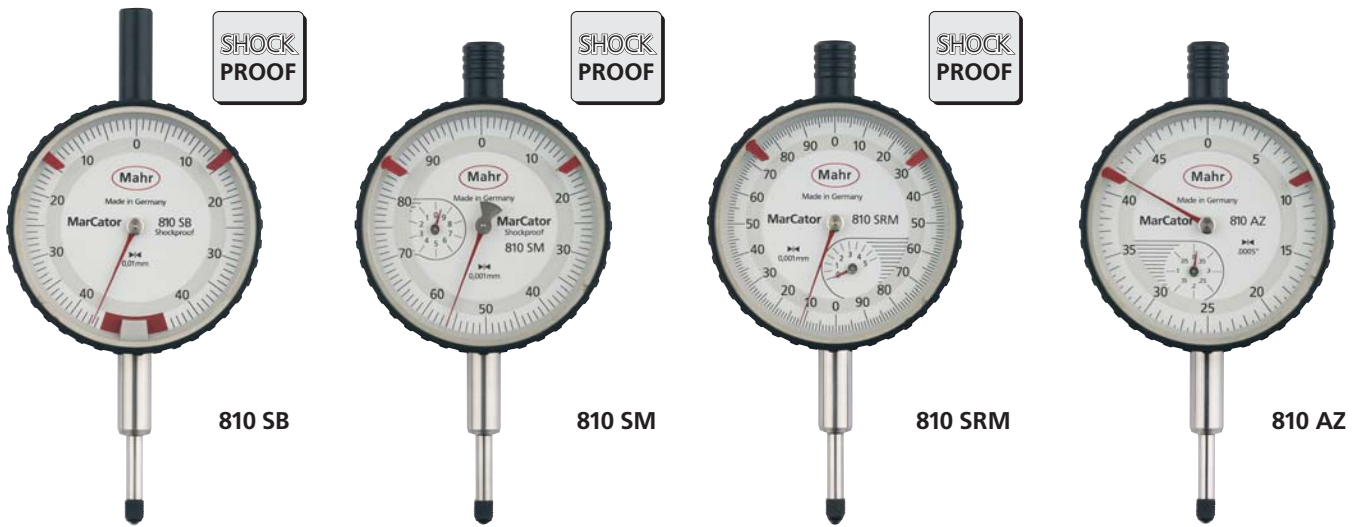

Features

Dial Indicator 810 SB
with limited measuring range

Design features identical to 810 S, with the following exceptions:

- Limited measuring range (0.8 mm) for error-free readings
- Large overtravel (ca. 9 mm) for easier insertion of test items in measuring devices
- Hermetically sealed protective measuring spindle cap

Dial Indicator 810 SM
Shockproof
with reading 0.001 mm

- Precise mechanism with a combined gear lever transmission
- High accuracy with a minimum span of error
- Lifter protection cap on the upper end of the measuring spindle
- Adjustable tolerance markers
- Chrome-plated housing

Dial Indicator 810 SRM
Shockproof
with reading 0.001 mm

- High precision gears and pinions
- Lifter protection cap on the upper end of the measuring spindle
- Adjustable tolerance markers
- Chrome-plated housing

Dial Indicator 810 AZ
Inch version

Design features are identical to 810 A, with the following exception:

- The scope of supply includes an Adapter Bush 940 for adapting mounting shank 8h6 mm to inch bore .375"

Dimensions according to DIN EN ISO 463

mm	a	b	c	d	e	f	g
810 A/AT	∅ 58	23	7.5	52	112	21	16
810 S	∅ 58	23	7.5	52	111.5	22	15
810 SW	∅ 61	24.15	7.9	52	127.6	22	22.1
810 SB	∅ 58	23	7.5	52	120	22	15
810 SM	∅ 58	25	8.5	52	111.5	22	15
810 SRM	∅ 58	23	7.5	52	111.5	22	15
810 AZ	∅ 58	23	7.5	52	111.5	22	15

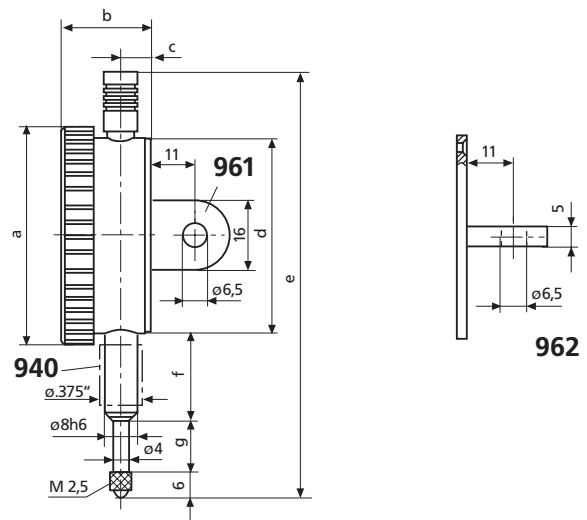

Precision Dial Indicators 810

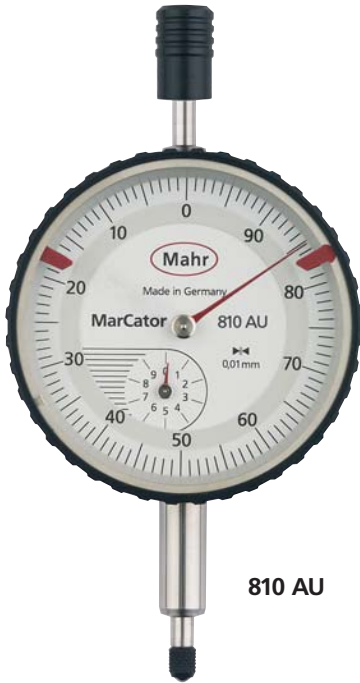

810 AU

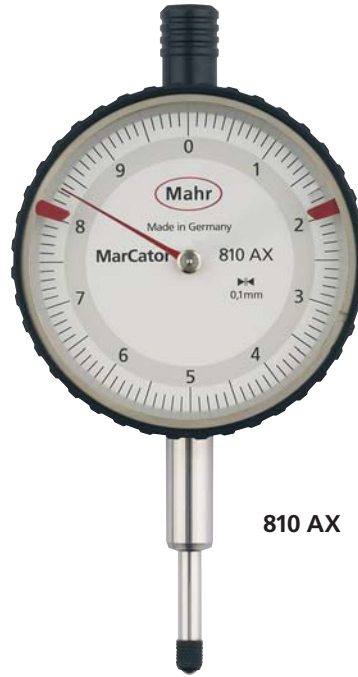
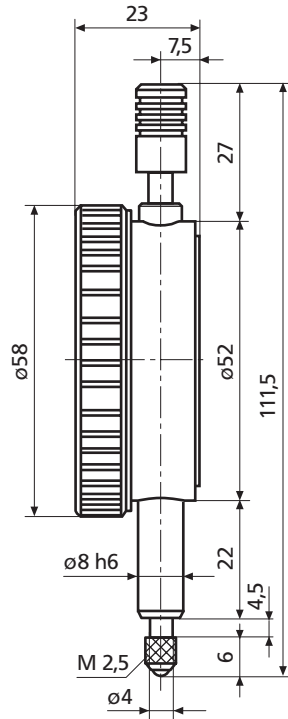

810 AX

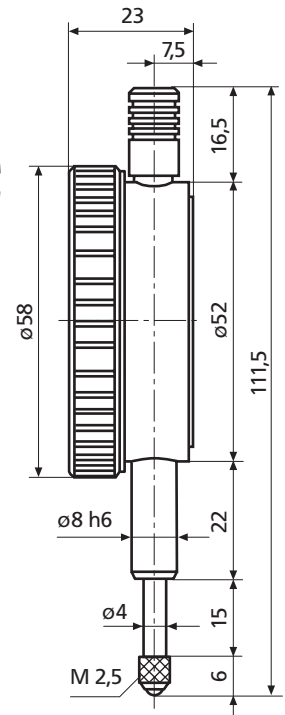

Features

Dial Indicator 810 AU

with a reversed measuring force direction

- Chrome-plated housing
- Adjustable tolerance markers
- Scale on the dial increases counter clockwise (+ on left)
- Measuring force acting towards the top
- Delivered in plastic case

Dial Indicator 810 AX

with reading 0.1 mm

- Constant measuring force
- Chrome-plated housing
- Adjustable tolerance markers
- 1 pointer movement on 10 mm
- Delivered in plastic case

Technical Data

	Range	Readings	Dial face dia.	Overtravel	Mounting shank dia.	Measuring force	Order no.
	mm	mm	mm	mm	mm	N	
810 AU	10	0.01	50	0.1	8h6	1 - 1.8	4329050
810 AX	10	0.1	50	0.5	8h6	0.7 - 1.3	4331000
810 SV	40	0.01	50	0.1	8h6	0.8 - 1.8	4321000
810 AG	10	0.01	108	0.1	8h6	1.3 - 2.2	4322000

Precision Dial Indicators 810

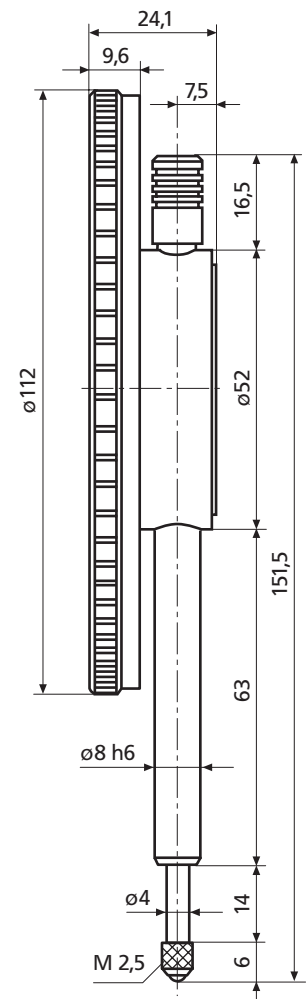
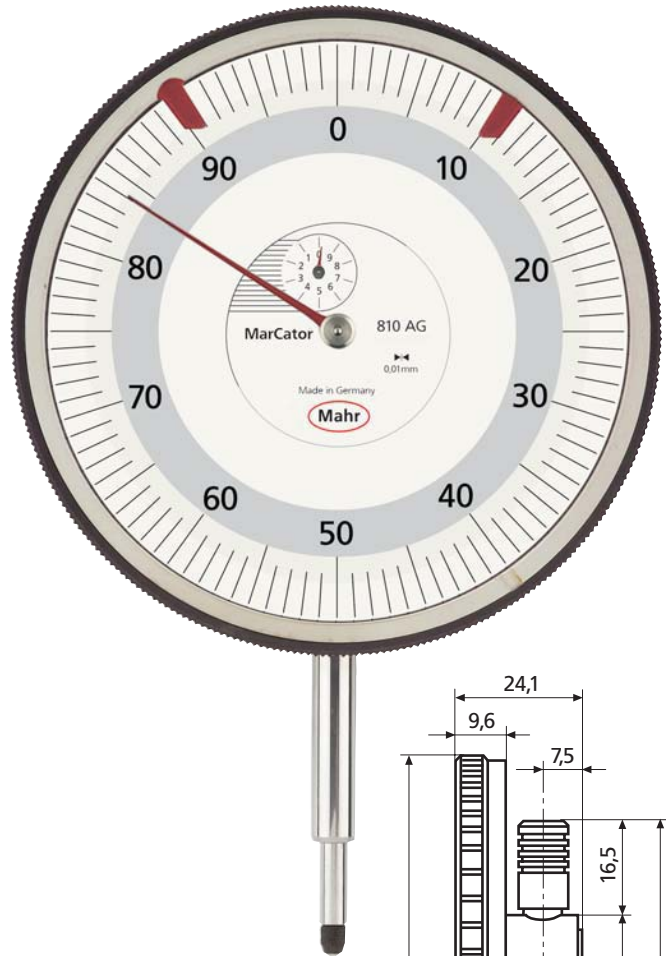
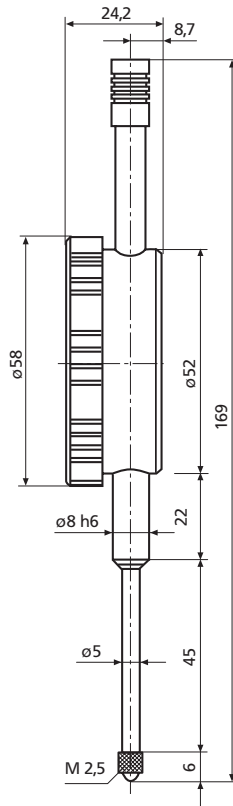
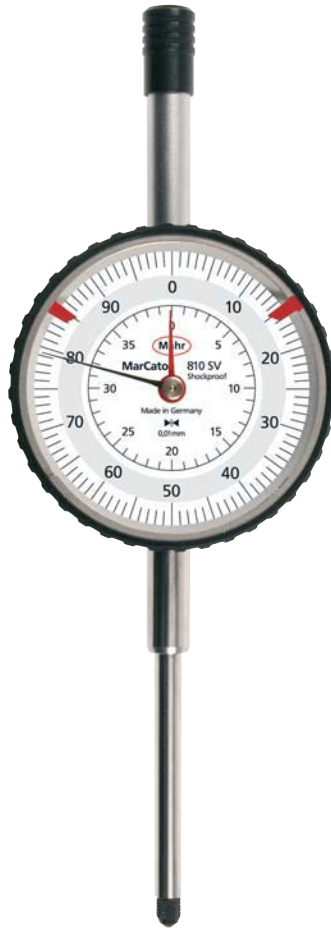

Features

Long Range Dial Indicator 810 SV

with larger measuring range

- Range 40 mm
- Strengthened measuring spindle (5 mm)
- Raising of measuring spindle via lifting cap
- Adjustable tolerance markers
- Shockproof movement
- Delivered in folded box

Extra large Dial Indicator 810 AG

with dial face dia. 108 mm

- Ideal for long reading distance and in bad light conditions
- Plastic outer ring
- Delivered in folded box















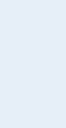





Accessories

Adapter Bush for adapting mounting shank 8h6 mm to inch bore .375"
Splash Guard Cover for dia. 58 mm
Mounting Lug to mount on mounting shank of all versions

	Order no.
940	4310103
955	4373020
963	4375002

MarCator. Digital Indicators (Long range)

OVERVIEW

Functions of Digital Indicators		1075	1080	1081	μMaxμmXLI	μMaxμmXLT Standard	μMaxμmXLT High accuracy
							
Catalog page		5 - 38	5 - 38	5 - 38	5 - 40	5 - 40	5 - 40
Measuring ranges		12.5 mm / .5"	12.5 mm / .5"	12.5 mm / .5"	12.5 mm / .5" 25 mm / 1"	50 mm / 2" 100 mm / 4"	50 mm / 2" 100 mm / 4"
Resolution	metric	0.01 mm	0.005 mm	0.001 mm	0.0005 mm	0.01 mm	0.001 mm
	inch	.0005"	.0001"	.00005"	.00002"	.0005"	.00005"
	metric				0.001 mm	0.02 mm	0.002 mm
	inch				.00005"	.001"	.0001"
	metric				0.002 mm	0.05 mm	0.005 mm
	inch				.0001"	.002"	.0002"
	metric				0.005 mm	0.1 mm	0.01 mm
	inch				.0002"	.005"	.0005"
	metric				0.01 mm		0.02 mm
	inch				.0005"		.001"
	metric				0.02 mm		0.05 mm
	inch				.001"		.002"
	metric						0.1 mm
	inch						.005"
Mounting shank		8h6	8h6	8h6	8h6 / 3/8"	8h6	8h6
Protection class	IP class acc. to IEC 60529						
Functions:							
ON/OFF		●	●	●	●	●	●
Set display to zero		●	●	●	●	●	●
Switch between mm/inch		●	●	●	●	●	●
Reversal of counting direction		●	●	●	●	●	●
Enter numerical value	PRESET	●	●	●	●	●	●
Data		●	●	●	●	●	●
ABS/REL-switchable							
Tolerance display					●	●	●
Dynamic measuring functions	MIN. MAX MAX-MIN (TIR)						
Search for reversal point	START/STOP						
Factor set / adjust							
Analog display						●	●
Switch the analog value						●	●
Key lock function LOC			●	●	●	●	●
Data output:	USB		●	●	●		
	Digimatic		●	●	●	●	●
	Opto RS232C		●	●	●		
Control output:							

Digital Indicators 1075 / 1080 / 1081



1075



1080



1081

Features

Functions:

- ON/OFF
- RESET (Set display to zero)
- mm/inch
- Reversal of counting direction
- PRESET (for entering a numerical value)
- DATA (data transmission with a data connection cable)
- LOCK-Function: keys can be blocked, only applies to 1081

- Inductive measuring system, life of battery ca. 2 years
- Max measuring speed 1.5 m/sec (60"/sec)
- MarConnect Data output: choose either
 USB
 OPTO RS232C
 Digimatic
- High contrast Liquid Crystal Display with 8.5 / 10 mm high digits
- Operating temperature 10-40°C
- Class of protection IP51 according to IEC 60529

Scope of supply:
 Battery,
 Operating instructions

Operating and display units
 (bezel) does not rotate

Technical Data

Measuring range mm (inch)	Resolution mm/inch	Span of error G * mm	Measuring force N	Weight g	Order no.
1075 12.5 (.5")	0.01/ .0005"	0.025	0.6 - 1	120	4336401
1080 12.5 (.5")	0.005/ .0001"	0.015	0.6 - 1	120	4336501
1081 12.5 (.5")	0.001/ .00005	0.005	0.5 - 1.1	120	4336350

* in any zero point

Digital Indicators 1075 / 1080 / 1081

Technical Data

- 1 Protection cap for lifter
- 2 Measuring spindle lifter
- 3 Display
- 4 Operating buttons
- 5 Mounting shank
- 6 Measuring spindle
- 7 Contact point 901
- 8 Data output
- 9 Battery compartment

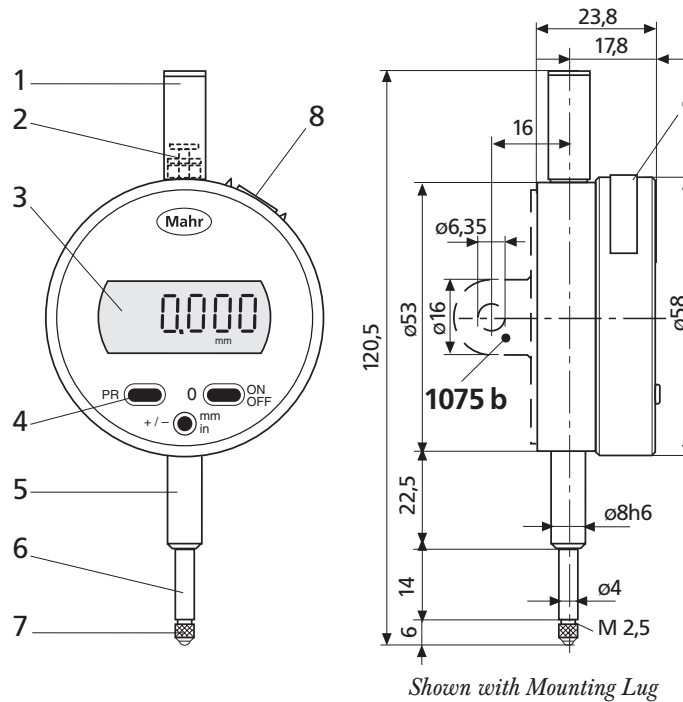

Accessories

	Order no.	Additional Accessories	Page
Battery 3V , Type CR 2032	4102520	Contact Points	901-913 5-52
Data Connection Cable USB (2 m)	16 EXu 4102357	Special Holder	941 5-53
Data Connection Cable Opto RS232C (2 m), with SUB-D jack 9-pin	16 EXr 4102410	Sensor Lever	943 5-53
Data Connection Cable Digimatic (2 m), Flat plug 10-pin	16 EXd 4102411	Accessories for Data Processing see Chapter 11	
Adapter bush for adapting mounting shank 8h6 mm to inch bore .375"	940 4310103		
Lug back	1075 b 4336565		

μMaxμm® XL Digital Indicators



XLI

XLT

XLI-57B-15

XLI Models & XLT Models

Range mm/ <i>inch</i>	"A" mm/ <i>inch</i>	"B" mm/ <i>inch</i>	"C" mm/ <i>inch</i>
12 / .5"	35.1 / 1.38"	68.6 / 2.7"	128.27 / 5.05"
25 / 1"	47.5 / 1.87"	81.3 / 3.2"	153.7 / 6.05"
50 / 2"	72.64 / 2.86"	153 / 6"	275.6 / 10.85"
100 / 4"	123 / 4.88"	253 / 9.97"	427 / 16.8"

Features

The μMaxμm XL Series offers all the benefits of Federal's μMaxμm Indicators and is designed for convenience, ease of use, dependability and rugged shop floor handling . . . plus:

- Long measuring ranges of 12.5 mm / .5", 25 mm / 1", 50 mm / 2" and 100 mm / 4".
- XLT incorporates switchable resolution.
- The XL never loses zero, even when powered down.
- Features easy to use controls.
- Preset capabilities for direct dimension readout.
- Unilateral tolerances.
- Go/no-go display for foolproof operation.
- Large digital/analog dual display for fast, accurate readings.
- Two-format data output, serial or Digimatic, is compatible with most data collection devices.
- World version furnished with metric stem sizes and contact threads.
- Versions also available for deadweight applications with compressible materials.
- Special ratio and lockout versions also available.
- Ask about our optional XLS versions for special custom configurations and lock out of various user and set up functions

Accessories

	Order no.
Right hand Lifting Lever, Left hand Lifting Lever	ELR-1092 ELR-1093

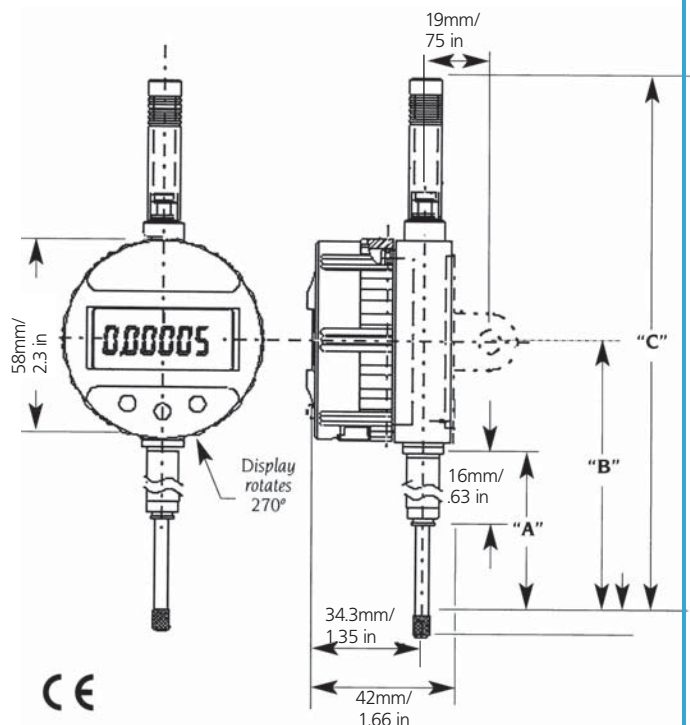

μMaxμm® XL Digital Indicators

Ordering Information

μMaxμm XL Indicators Model Number:		XLI-	X		X	0	0	X
Model	Range	Stem Diameter / Length	Code	Ratio	Code	Back		Code
U.S. version	0.5"	.375" / 0.63"	1	1:1	0	Flat Back (EBK-1020)		0
U.S. version	1.0"	.375" / 0.63"	2			Lug (BK-183) vert/horiz		1
World version	12.5 mm	8 mm/ 16 mm	3	4/5	1	Adjustable (BK-531)		2
World version	25 mm	8 mm/ 16 mm	4			Post (BK-2093)		3
World version	25 mm	8 mm/ No spring	5*			Screw (BK-692)		4
						Adaptor back for 75B Gage (EPL-1914)		5
						Rack Back (BK-93)		

* Deadload Model (used with weights)

Examples: **XLI-10001** is a μMaxμm XL with 0.5" range, .375" stem diameter, 0.63" / 16 mm stem length, and a Lug Back.

μMaxμm XLT Indicators* Model Number:		XLT-	X	0	0	0	X
Version	Range	Stem Diameter / Length	Accuracy	Code	Back		Code
World	50 mm	8 mm / 15 mm	High: 8 μm/. 00032"	1	Flat Back (EBK-1020)		0
World	50 mm	8 mm / 15 mm	Std: 20 μm/. 0008"	2	Lug (BK-383)		1
World	100 mm	8 mm / 15 mm	High: 9 μm/. 00036"	3	Adjustable (BK-531)		2
World	100 mm	8 mm / 15 mm	Std: 20 μm/. 0008"	4	Post (BK-2093)		3
					Screw (BK-692)		4

For additional contact points see pages 5-22, 5-27, 5-52 & 5-53

XLT Models include 3/8" bushing and M2.5 thread contact. Adaptor AD-185 provided when selecting a 4-48 threaded Contact Point

Technical Data

Model no.	Range mm/ <i>inch</i>	Resolution mm/ <i>inch</i>	Accuracy mm/ <i>inch</i>	Gage Force	Weight
XLI Resolution Selectable	12.7/ .50"	0.0005/ .00002" ** 0.001/ .00005" 0.002/ .0001" 0.005/ .0002"	0.005/ .0002"	0.8 N / 3-4 oz.	200 g / 7 oz.
	25.4/ 1.0"	0.01/ .0005" 0.02/ .001"			
XLT Standard Accuracy Resolution Selectable	50/ 2.0"	0.01/ .0005" 0.02/ .001"	0.02/ .0008"	0.8 - 1 N / 7 - 11 oz.	200 g / 10 oz.
	100/ 4.0"	0.05/ .002" 0.1/ .005"		2.3 - 4 N / 8 - 14 oz.	340 g / 12 oz.
XLT High Accuracy Resolution Selectable	50/ 2.0"	0.001/ .00005" 0.002/ .0001" 0.005/ .0002" 0.01/ .0005"	0.008/ .00032"	0.8 - 1 N / 7 - 11 oz.	200 g / 10 oz.
	100/ 4.0"	0.02/ .001" 0.05/ .002" 0.1/ .005"	0.009/ .00036"	2.3 - 4 N / 8 - 14 oz.	340 g / 12 oz.

** XLS Models only

XL Common Specification Values

Output	Serial BCD, 13 digits, 52 bits; ASCII encoded 2400 baud asynchronous stream.
Spindle Velocity	60 in/sec (1.5m/sec) Maximum
Operating Temps	40° to 105° F / 5° to 40° C
Storage Temps	- 40° to 140° F / -20° to 60° C
Repeatability	± 1 least significant digit
Battery life	12 months normal use or 4000 hours. (May vary with "Auto Power Down Option")

MarCator 1086

► | The new Digital Indicator **MarCator** 1086. With the large display and the integrated tolerance function, your measurement results are clearly visual. | ◀

Clear display

Tolerance indication with the displayed value

Displayed is the actual measured value and the tolerance zone position

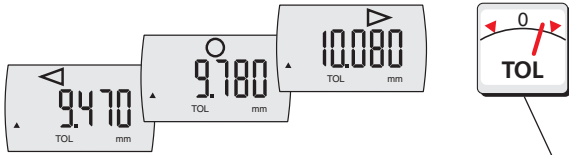

Tolerance indication without the value in the display. In and Out of tolerance will be indicated in the display as a symbol.

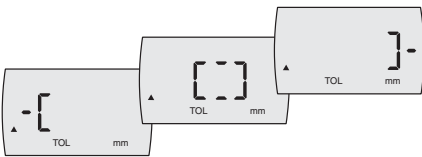

- IP Protection class IP54** (optional)
- Protection cap is sealed
 - Rubber bellows for the measuring spindle
 - Sealed battery compartment



Code Initial	IP	International Protection
First Numeral	5	Dust protected
Zweite Numeral	4	Protection against splash water in all directions

Universal Data-Interface



- **USB**
No interface box is required! Simple and inexpensive way to set up a multiple measuring instruments via a USB hub



- **Digimatic**
To connect a Digimatic compatible evaluation instrument



- **Mahr Opto RS232C**
For direct connection to a COM port on a PC



- **Absolute function:**
Digital Indicator can be set in any position to 0.000 without losing the reference to the preset value.

Error free operation - Lock function

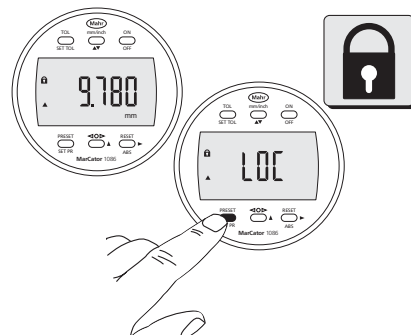

Lock function: This prevents unintentional activation of an operating button. Either all the operating buttons or only certain individual buttons can be locked. If a locked operating button is pressed the "LOC" symbol will appear in the display.

Digital Indicators MarCator 1086 / 1086 Z, Resolution 0.01 mm / .0005"

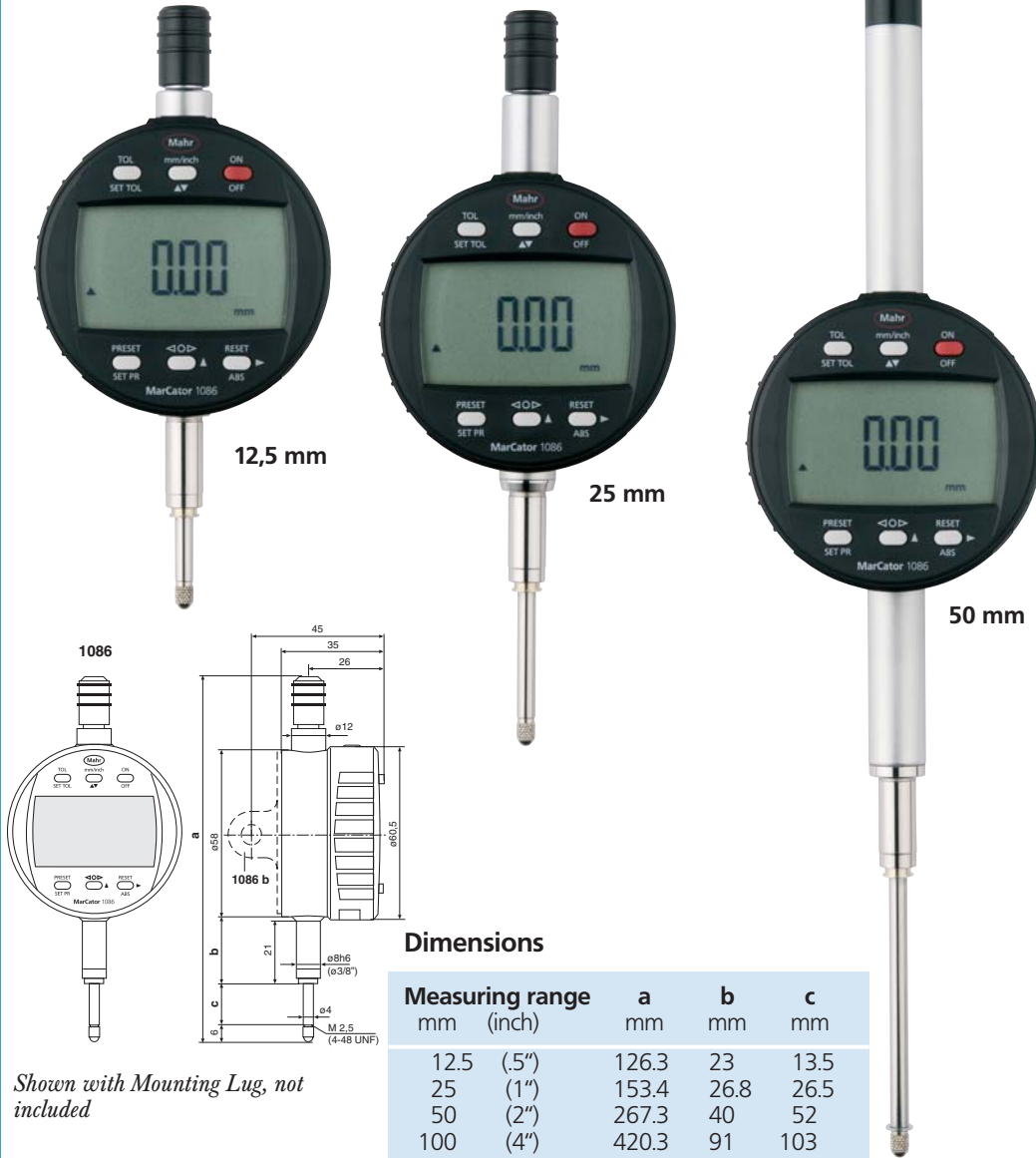

Shown with Mounting Lug, not included

Dimensions

Measuring range		a	b	c
mm	(inch)	mm	mm	mm
12.5	(.5")	126.3	23	13.5
25	(1")	153.4	26.8	26.5
50	(2")	267.3	40	52
100	(4")	420.3	91	103

Features

Functions:

- ON/OFF
- RESET (Set display to zero)
- mm/inch
- Reversal of the counting direction
- PRESET (Allows the entry of any value using set buttons)
- TOL (Enter tolerance limit values)
- ABS (Display can be set to zero, without losing the reference to the Preset value)
- <0> (Tolerance GO / NO GO display mode)
- DATA (when connected with a data connection cable)
- Factor (adjustable)
- Individual buttons can be locked
- Operating and display unit (bezel) can be rotated through 280°
- High contrast LCD with 11 mm high digits
- Inductive measuring system, battery life ca. 2000 hrs.
- Maximum measuring speed 1.5 m/s (60"/s)
- Lifter protection cap on the measuring spindle
- MarConnect data output: choose either USB, OPTO RS232C, Digimatic
- Operating temperature 10 - 40°C
- Class of protection IP42 in accordance to IEC 60529

Supplied with:
Battery, operating instructions

Technical Data

Measuring range		Resolution	Span of error*	Repeatability	Measuring force	Weight	Mounting shank	Order no.
mm	(inch)	mm/inch	mm	mm	N	g	dia.	
12.5	(.5")	0.01/ .0005"	0.02	0.01	0.65 - 0.90	130	8h6	4337030
25	(1")	0.01/ .0005"	0.02	0.01	0.65 - 1.15	140	8h6	4337031
50	(2")	0.01/ .0005"	0.02	0.01	1.25 - 2.70	190	8h6	4337032
100	(4")	0.01/ .0005"	0.02	0.01	1.60 - 3.50	235	8h6	4337033
12.5	(.5")	0.01/ .0005"	0.02	0.01	0.65 - 0.90	150	3/8"	4337055
25	(1")	0.01/ .0005"	0.02	0.01	0.65 - 1.15	160	3/8"	4337056

* in any zero point

Digital Indicators MarCator 1086 / 1086 Z, Resolution 0.001 mm / .00005"



12,5 mm



25 mm



50 mm

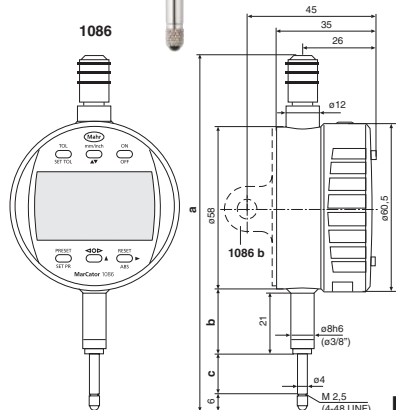

Dimensions

Shown with Mounting Lug, not included

Measuring range		a	b	c
mm	(inch)	mm	mm	mm
12.5	(.5")	126.3	23	13.5
25	(1")	153.4	26.8	26.5
50	(2")	267.3	40	52
100	(4")	420.3	91	103

Features

Functions:

- ON/OFF
- RESET (Set display to zero)
- mm/inch
- Reversal of the counting direction
- PRESET (Allows the entry of any value using set buttons)
- TOL (Enter tolerance limit values)
- ABS (Display can be set to zero, without losing the reference to the Preset value)
- <0> (Tolerance GO / NO GO display mode)
- DATA (when connected with a data connection cable)
- Factor (adjustable)
- Individual buttons can be locked
- Operating and display unit (bezel) can be rotated through 280°
- High contrast LCD with 11 mm high digits
- Inductive measuring system, battery life ca. 2000 hrs.
- Maximum measuring speed 1.5 m/s (60"/s)
- Lifter protection cap on the measuring spindle
- MarConnect data output: choose either USB, OPTO RS232C, Digimatic
- Operating temperature 10 - 40°C
- Class of protection IP42 in accordance to IEC 60529

Supplied with:
Battery, operating instructions

Technical Data

Measuring range		Resolution	Span of error*	Repeatability	Measuring force	Weight	Mounting shank	Order no.
mm	(inch)	mm/inch	mm	mm	N	g	dia.	
12.5	(.5")	0.001/ .00005"	0.005	0.002	0.65 - 0.90	130	8h6	4337020
25	(1")	0.001/ .00005"	0.005	0.002	0.65 - 1.15	140	8h6	4337021
50	(2")	0.001/ .00005"	0.008	0.002	1.25 - 2.70	190	8h6	4337022
100	(4")	0.001/ .00005"	0.009	0.002	1.60 - 3.50	235	8h6	4337023
12.5	(.5")	0.001/ .00005"	0.005	0.002	0.65 - 0.90	150	3/8"	4337050
25	(1")	0.001/ .00005"	0.005	0.002	0.65 - 1.15	160	3/8"	4337051

* in any zero point

Digital Indicators MarCator 1086 W, Waterproof version



12,5 mm



25 mm

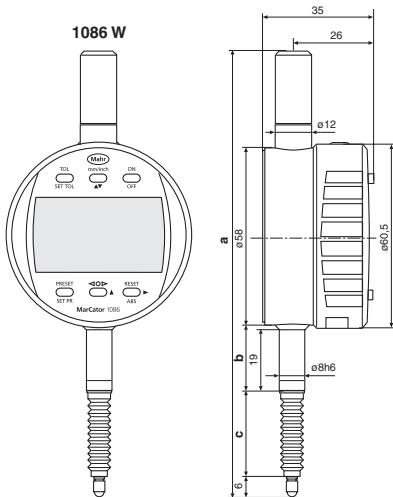

Dimensions

Measuring range		a	b	c
mm	(inch)	mm	mm	mm
12.5	(.5")	144.3	23	28.6
25	(1")	193.2	26.8	50

Features

Functions:

- ON/OFF
- RESET (Set display to zero)
- mm/inch
- Reversal of the counting direction
- PRESET (Allows the entry of any value using set buttons)
- TOL (Enter tolerance limit values)
- ABS (Display can be set to zero, without losing the reference to the Preset value)
- <0> (Tolerance GO / NO GO display mode)
- DATA (when connected with a data connection cable)
- Factor (adjustable)
- Individual buttons can be locked
- Operating and display unit (bezel) can be rotated through 280°
- High contrast LCD with 11 mm high digits
- Inductive measuring system, battery life ca. 2000 hrs.
- Maximum measuring speed 1.5 m/s (60"/s)
- Sealed protection cap
- Measuring spindle is sealed with a rubber bellows, thus preventing contamination by liquids and impurities
- MarConnect data output: choose either
 USB
 OPTO RS232C
 Digimatic
- Operating temperature 10 - 40°C
- Class of protection IP54 in accordance to IEC 60529

Supplied with:
 Battery, operating instructions

Technical Data

Measuring range		Resolution	Span of error*	Repeatability	Measuring force	Weight	Order no.
mm	(inch)	mm/inch	mm	mm	N	g	
12.5	(.5")	0.001/ .00005"	0.005	0.002	0.65 - 1.40	135	4337040
25	(1")	0.001/ .00005"	0.005	0.002	1.00 - 2.25	145	4337041
12.5	(.5")	0.01/ .0005"	0.02	0.01	0.65 - 1.40	135	4337045
25	(1")	0.01/ .0005"	0.02	0.01	1.00 - 2.25	145	4337046

* in any zero point

MarCator 1087

► | The new Digital Indicator **MarCator** 1087. The multi-functional Digital Indicator has a combined analog and digital display as well as tolerance and dynamic measuring functions. | ◀

Dynamic measuring functions

- **MAX-MIN**-Function ideal for testing flatness and concentricity
- **MAX** and / or **MIN** for searching the reversal point

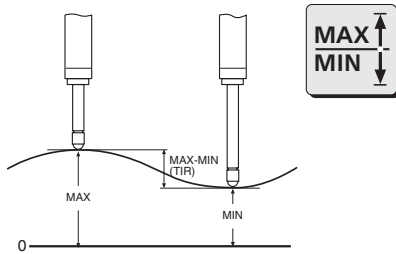

Universal Data-Interface



- **USB**
No interface box is required! Simple and inexpensive way to set up a multiple measuring instruments via a USB hub



- **Digimatic**
To connect a Digimatic compatible evaluation instrument



- **Mahr Opto RS232C**
For direct connection to a COM port on a PC

Clear display Tolerance indication

The integrated bar graph visualizes the tolerance deviation. The out of tolerance; whether above the upper or below the lower tolerance limit is represented by arrows shown in the display.

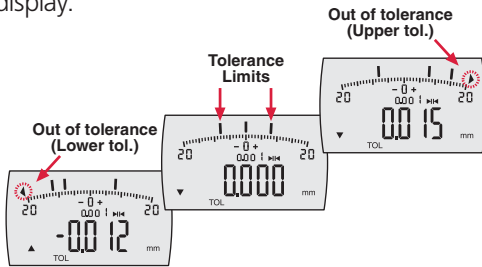

- **Absolute function:**
Digital Indicator can be set in any position to 0.000 without losing the reference to the preset value.

Factor is adjustable a symbol with appear in the display

Example of application:
- Chamfer Gage



Error free operation - Lock function

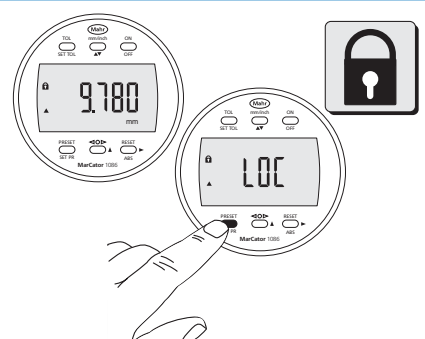

Lock function: This prevents unintentional activation of an operating button. Either all the operating buttons or only certain individual buttons can be locked. If a locked operating button is pressed the "LOC" symbol will appear in the display.

Digital Indicators MarCator 1087 / 1087 Z, with analog display



12,5 mm



25 mm

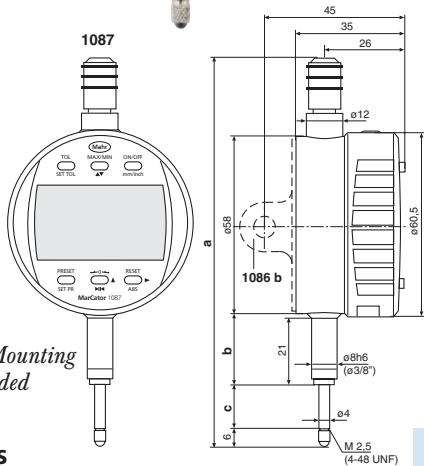

Shown with Mounting Lug, not included

Dimensions

Measuring range	a	b	c
mm (inch)	mm	mm	mm
12.5 (.5")	126.3	23	13.5
25 (1")	153.4	26.8	26.5

Analog display

Readings	Display range
mm / inch	mm / inch
0.001 / .00005	± 0.02 / ± .001
0.002 / .0001	± 0.04 / ± .002
0.004 / .0005	± 0.08 / ± .01
0.01 / .001	± 0.2 / ± .02

Features

Functions:

- ON/OFF
- RESET (Set display to zero)
- mm/inch
- Reversal of the counting direction
- PRESET (Allows the entry of any value using set buttons)
- TOL (Enter tolerance limit values)
- Tolerance band max. 1.6 mm
- MAX/MIN memory, ideal for searching the reversal point
- TIR (MAX-MIN) ideal for testing concentricity and flatness
- ABS (Display can be set to zero, without losing the reference to the Preset value)
- 0 (Set the analog display to zero)
- DATA (when connected with a data connection cable)
- Factor (adjustable)
- Individual buttons can be locked
- Operating and display unit (bezel) can be rotated through 280°
- High contrast LCD with 8.5 mm high digits
- Inductive measuring system, battery life ca. 2000 hrs.
- Maximum measuring speed 1.5 m/s (60"/s)
- MarConnect data output: choose either USB, OPTO RS232C, Digimatic
- Operating temperature 10 - 40°C
- Class of protection IP42 in accordance to IEC 60529

Supplied with: Battery, operating instructions

Technical Data

Measuring range	Resolution	Span of error*	Repeatability	Measuring force	Weight	Mounting shank	Order no.
mm (inch)	mm/inch	mm	mm	N	g	dia.	
12.5 (.5")	0.001/ .00005"	0.005	0.002	0.65 - 0.90	140	8h6	4337060
25 (1")	0.001/ .00005"	0.005	0.002	0.65 - 1.15	150	8h6	4337061
12.5 (.5")	0.001/ .00005"	0.005	0.002	0.65 - 0.90	150	3/8"	4337070
25 (1")	0.001/ .00005"	0.005	0.002	0.65 - 1.15	160	3/8"	4337071

* in any zero point

MarCator 1088

▶ | The new Digital Indicator **MarCator** 1088. Tolerance monitoring is simplified with the changing of the color in the background lit display. | ◀

Dynamic measuring functions

- MAX-MIN memory: ideal for testing flatness and concentricity
- MAX-MIN memory: for searching the reversal point



Tolerance function: clearly visual tolerance excess due to the change of color in the background lit display.



Universal Data-Interface



- **USB**
No interface box is required! Simple and inexpensive way to set up a multiple measuring instruments via a USB hub



- **Digimatic**
To connect a Digimatic compatible evaluation instrument



- **Mahr Opto RS232C**
For direct connection to a COM port on a PC

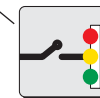

Control output can be connected to a SPS



Absolute function: Digital Indicator can be set in any position to 0.000 without losing the reference to the preset value.

Protection class IP54 according to IEC 60529. Especially suited for use in a manufacturing environment (excludes measuring range 50 mm)



Code Initial	IP	International Protection
First Numeral	5	Dust protected
Second Numeral	4	Protection against splash water in all directions



Analog display

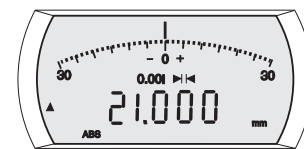

Readings
(switchable)
mm / inch

Display range
mm / inch

0.001 / .00005"
0.002 / .0001"
0.005 / .0005"
0.01 / .001"

± 0.030 / ± .0015"
± 0.060 / ± .0030"
± 0.150 / ± .0150"
± 0.30 / ± .030"

Digital Indicators MarCator 1088 / 1088 W, with analog display

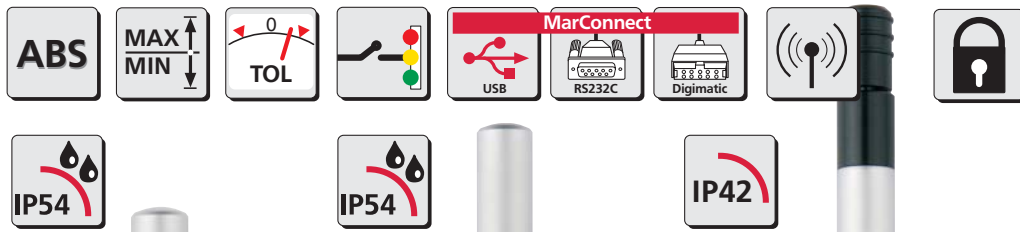

12,5 mm



25 mm



50 mm

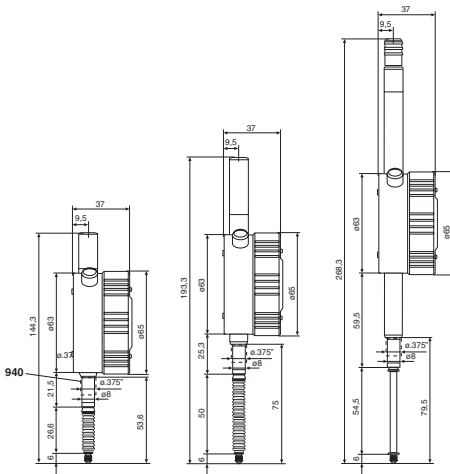

Features

Functions:

- ON/OFF
- RESET (set digital and analog displays to zero)
- 0 - (set the analog display to zero)
- PRESET (enter any numerical values)
- DATA (data transmission)
- mm/inch-switchable
- Reversal of counting direction (switch value in digital display)
- MAX-MIN memory, ideal for searching the reversal point
- MAX-MIN memory, e.g. for testing flatness and concentricity
- TOL (Enter tolerance limit values)
- Tolerance band max. 1.6 mm
- LOCK: operating functions can be blocked via PC-Software
- Power supply via the main power adapter
- MarConnect data output: USB, OPTO RS232C, or Digimatic
- Can be remotely operated via the interface (Opto RS232C)
- Control output compatible to Dial Comparators with limit contacts
- Operating and display unit (bezel) can be rotated 280°
- Class of protection IP54 in accordance to IEC 60529
- Operating temperature 5 - 40°C
- High contrast backlit LCD with 6.5 mm high digits
- Analog display with 4 mm pointer ensures better visual recognition, ideal when checking concentricity or flatness as well as searching for the reversal point when measuring bores
- Supplied with: Mains adapter, rubber bellows, operating instructions

Technical Data

Measuring range	Resolution	Measuring force	Span of error*	Protection class	Order no.	Order no.
mm (inch)	mm/inch	N	mm		230 V	115 V
12.5 (.5")	0.001/ .00005"	0.65 - 1.40	0.005	IP54	4337000	4337010
25 (1")	0.001/ .00005"	1.00 - 2.25	0.005	IP54	4337001	4337011
50 (2")	0.001/ .00005"	1.25 - 2.7	0.008	IP42	4337002	4337012

* in any zero point

Digital Indicator MarCator 1087 B for 2 point inside measurement



12,5 mm

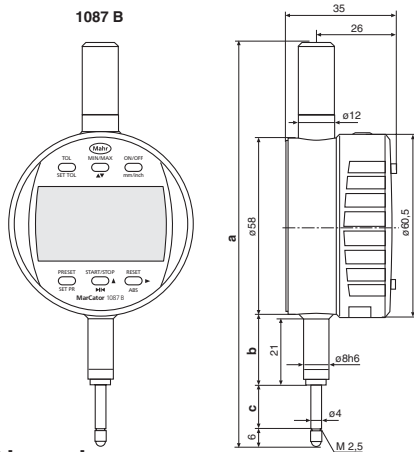

Dimensions

Measuring range mm (inch)	a mm	b mm	c mm
12.5 (.5")	131	23	13.5

Example of application

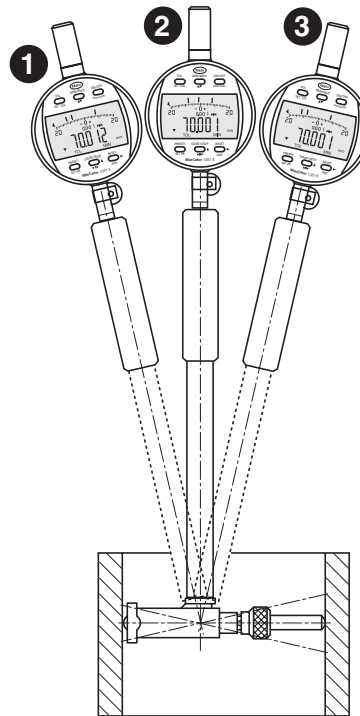

With a 2 point inside measuring instrument the point of reversal is automatically determined through rocking back and forth. The actual value is detected and stored by the MIN function and indicated in the display (3).

Features

Functions:

- ON/OFF
- RESET (Set the display to zero) mm/inch
- Reversal of the counting direction
- PRESET (Allows the entry of any value using set buttons)
- TOL (Enter tolerance limit values)
- Tolerance band max. 1.6 mm
- START/STOP for searching the reversal point
- MAX/MIN memory, ideal for searching the reversal point
- ABS (Display can be set to zero, without losing the reference to the Preset value)
- 0 (Set analog display to zero)
- DATA (when connected with a data connection cable)
- Factor (adjustable)
- Individual keys can be locked
- Operating and display unit (bezel) can be rotated 280°
- High contrast LCD with 8.5 mm high digits
- Inductive measuring system, battery life ca. 2000 hrs.
- Maximum measuring speed 1.5 m/s (60"/s)
- Sealed protection cap
- MarConnect data output: choose either USB, OPTO RS232C, Digimatic
- Operating temperature 10 - 40°C
- Class of protection IP42 in accordance to IEC 60529
- Supplied with: Battery, operating instructions

Analog display

Readings mm / inch	Display range mm / inch
0.001 / .00005	± 0.02 / ± .001
0.002 / .0001	± 0.04 / ± .002
0.004 / .0005	± 0.08 / ± .01
0.01 / .001	± 0.2 / ± .02

Technical Data

Measuring range mm (inch)	Resolution mm/inch	Span of error* mm	Repeatability mm	Measuring force N	Weight g	Mounting shank dia.	Order no.
12.5 (.5")	0.001/.00005"	0.005	0.002	0.65 - 0.90	140	8h6	4337062

* in any zero point

Accessories for MarCator 1086, 1087 und 1088

Accessories for MarCator 1086 and 1087

	Order no.
Battery 3V , Type CR 2450	4884464
Data Connection Cable USB (2 m)	16 EXu 4102357
Data Connection Cable Opto RS232C (2 m), with SUB-D jack 9-pin	16 EXr 4102410
Data Connection Cable Digimatic (2 m), Flat plug 10-pin	16 EXd 4102411
Mounting Lug	1086 b 4337421
Rubber bellows for 1086 W - 12.5 mm	4337472
Rubber bellows for 1086 W - 25 mm	4337474

Accessories for MarCator 1088

	Order no.
Data Connection Cable USB (2 m)	2000 usb 4346023
Data Connection Cable Opto RS232C (2 m), with SUB-D jack 9-pin	2000 r 4346020
Data Connection Cable Digimatic (2 m), Flat plug 10-pin	2000 d 4346021
Cable to connect control output to an SPS	2000 sps 4346031
Mounting Lug	1085 b 4336310
Rubber bellows for 1088 W - 12.5 mm	4337472
Rubber bellows for 1088 W - 25 mm	4337474
Control Instrument for remote control operation	2000 sg 4346035

Accessories for MarCator 1086, 1087 and 1088

	Order no.	
Cable Release for measuring ranges 12.5 and 25 mm	1085 a 4336311	
Pneumatic Lifter for measuring ranges 12.5 and 25 mm	1082 p 4336237	
Pneumatic Lifter for measuring ranges 50 and 100 mm	1082 p 4336230	
Additional Accessories		Page
Contact Points	901-913	5-52
Special Holder	941	5-53
Sensor Lever	943	5-53

Accessories for Data Processing see Chapter 11

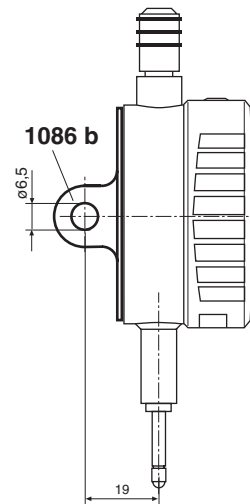

1085 a

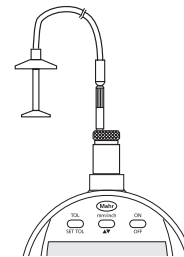

1082 p (12,5/25)

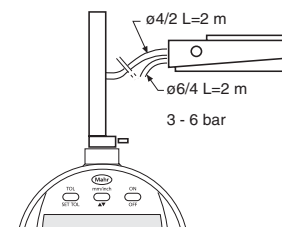

1082 p (50/100)

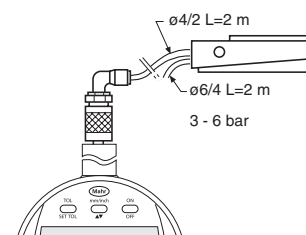

Contact Points and Accessories for Dial Indicators, Dial Comparators and Probes

Standard Contact Points 901

Ball dia. 3 mm

Catalog no.		Order no.
901	with steel ball	4360001
901 H	with carbide ball	4360002
901 R	with ruby ball	4360003

Spherical Contact Points 902 Flat Contact Points 903

902	902 H	903	903 H
Steel	Carbide contact face	Steel	Carbide tipped
Length mm	Order no.	Order no.	Order no.
4	4360007	-	4360070
6	4360009	-	4360071
8	4360010	4360040	4360072
10	4360011	4360041	4360073
12	4360012	4360042	4360074
15	4360013	4360043	4360075
20	4360014	4360044	4360076
25	4360015	4360045	4360077
30	4360016	4360046	4360300
35	4360017	4360047	4360078
40	4360019	4360049	4360310
45	4360026	4360050	4360303
50	4360018	4360048	4360079
55	4360031		4360109
65	4360035		
75	4360020		
85	4360036		
95	4360029		

Ball Contact Point 906 H

with carbide ball. accuracy ball dia. 0/-6µm

Ball dia. d mm	l mm	Order no.	Ball dia. d mm	l mm	Order no.
1	8.5	4360150	5.5	9	4360161
1.25	8.5	4360151	6	9	4360162
1.5	8.5	4360152	6.35 (1/4")	9	4360163
1.75	8.5	4360153	6.5	10	4360164
2	8.5	4360154	7	10	4360165
2.5	8.5	4360155	7.5	11	4360166
3	8.5	4360156	8	11	4360167
3.5	8.5	4360157	8.5	12	4360168
4	8.5	4360158	9	12	4360169
4.5	8.5	4360159	10	13	4360170
5	9	4360160			

Contact Rollers 909

Concentricity error 3 µm

	Order no.
Cylindrical Roller	909 A 4360220
Radiused Roller, R = 5 mm	909 B 4360221

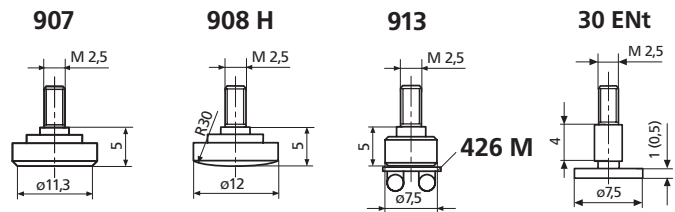
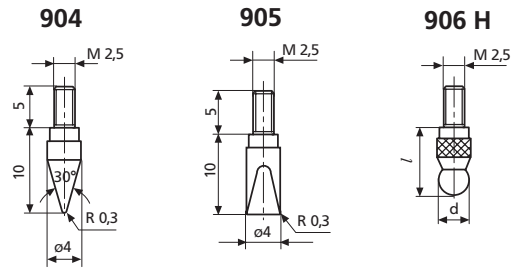
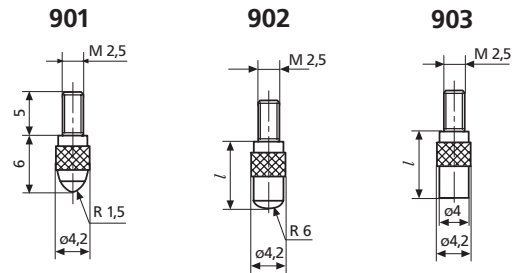

Special Contact Points

	Order no.
Conical Contact Points, Steel	904 4360130
Carbide tipped	904 H 4360131
Wedge Shaped Contact Points, Steel	905 4360140
Carbide tipped	905 H 4360141
Flat Contact Points, Steel, A = 1 cm²	907 4360200
Carbide tipped, dia. 7 mm	907 H 4360201
Spherical Contact Points, Steel	908 4360210
Carbide tipped	908 H 4360211
Flat Contact Point, for mounting	
Pin Gage Holder 426 M for measuring threads using three-wire method	913 4360400
Disc Type anvil thickness 0.5 mm, hardened	30 ENT 4126310
Disc Type anvil thickness 1 mm, hardened	30 ENT 4882022

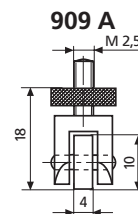

Contact Points and Accessories for Dial Indicators, Dial Comparators and Probes

Measuring Attachment 910 H

	Order no.
with parallel adjustable carbide blades	910 H 4360230

Pin Contact Point 911

dia. 1.5 mm, flat

Length <i>l</i> mm	Order no.	Length <i>l</i> mm	Order no.
15	4360280	35	4360284
20	4360281	40	4360285
25	4360282	50	4360286
30	4360283		

Pin Contact Point 911 H

	Order no.
Carbide tipped, dia 1 mm, flat	911 H1 4360240
Carbide tipped, dia 1.5 mm, flat	911 H2 4360241

Measuring Spindle Extensions 912

Length <i>l</i> mm	Order no.	Length <i>l</i> mm	Order no.
10	4360250	35	4360254
15	4360251	50	4360255
20	4360252	75	4360256
25	4360253	100	4360257

Special Holder 941

For all types of measuring equipment
 For placing a dial indicator at a certain distance or angle
 Travel of the measuring spindle 3 mm
 Contact Point 901 (interchangeable)

Straight Holder 941 G
 Mounting shank length *l*₁

25	4365000
50	4365001
75	4365002

Angular Holder 941 W

Order no.	<i>l</i> ₂ mm	Order no.	<i>l</i> ₂ mm	Order no.	<i>l</i> ₂ mm
Angle α=45°	53.7	Angle α=60°	49.3	Angle α=90°	34.5
4365010		4365020		4365030	
4365011		4365021		4365031	
4365012		4365022		4365032	

Sensor Level 943

	Order no.
For testing concentricity in bore holes as well as difficult to reach outside diameters To be inserted in a measuring stand with a lifting device Contact Point 901 interchangeable Travel ±1 mm	4367000

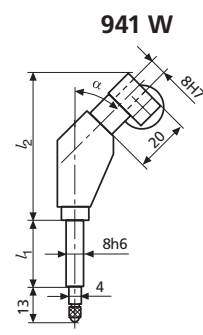
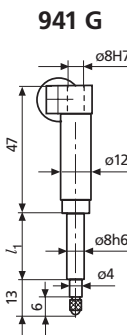
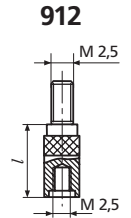
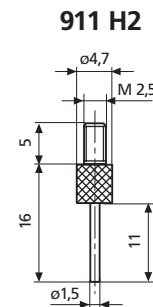
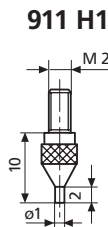
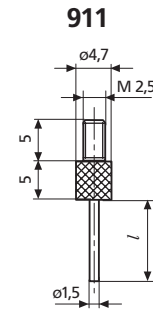
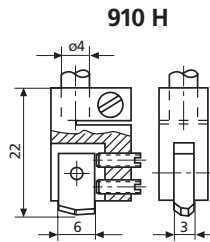

Transmission error with the 941 W
 max. 1%;
 for travel 3 mm = 0.03 mm

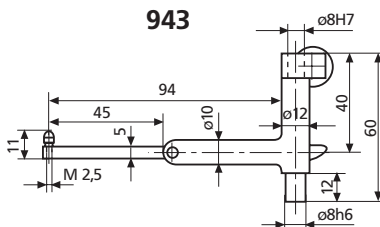

SIMPLE, ACCURATE AND INEXPENSIVE MEASUREMENT. MILLIMESS DIAL COMPARATORS.



The latest information on MILLIMESS products can be found on our website:

www.mahr.com, WebCode 207

▶ | Millimess is the "classic" amongst all measuring instrument. For over 60 years the Millimess series of dial comparators has been synonymous with both high precision and extreme robustness. Both maximum accuracy and a minimal reversal span error are obtained through the levers, gears and pinions being supported with jeweled bearings and that the measuring spindle running in a ball bush guide. Millimess is therefore particularly suitable for measuring tasks where the accuracy and the reversal span of a conventional dial indicator are not sufficient. Further advantages of Millimess are the simple handling, the easy reading as well as the movement being absolute shockproof. With a digital comparator with an inductive measuring system combined with most modern state of the art digital technology readings as small as $0.2 \mu\text{m}$ / $10 \mu\text{inch}$ are realized. The practical control functions (for example tolerance monitoring or the storage of measuring values for dynamic measurements), the combined analog and digital display as well as the easy to use data transmission rounds off the complete Millimess spectrum.

▶ | Millimes. Digital and Dial Comparators

Inductive Digital Comparators

Overview 6- 2

Millimes 2100 6- 4

With background lit digital and analog display

Millimes 2000 / 2001 6- 5

With digital and analog display

μMaxμm 6- 7

With digital display

Maxμm III 6-10

With digital and analog display, probe

Mechanical Dial Comparators

Overview 6-14

Millimes 1000 A / 1000 B 6-17

With large dial

Millimes 1002 /1003 / 1003 XL / 1004 / 1010 / 1050 6-18

Standard versions





Millimes 1110 N / 1150 N 6-20

With limit contacts



Millimes. Digital Comparators (Short range)

OVERVIEW

Inductive Digital Comparators					
	2100	2000	2001	μMaxµm	Maxµm III
					
Catalog page	6 - 3	6 - 5	6 - 5	6 - 7	6 - 8
Measuring range	2.8 mm	1.8 mm	1.8 mm	2 mm	2 mm/ 3.98 mm
Resolution	mm / inch 0.0005 / .00002" 0.001 / .00005" 0.005 / .0002" 0.01 / .0005"	mm / inch 0.0002 / .00001" 0.0005 / .00002" 0.001 / .00005"	mm / inch 0.0002 / .00001" 0.0005 / .00002" 0.001 / .00005"	mm / inch 0.0005 / .00002" 0.001 / .00005" 0.001 / .0001" 0.005 / .0002" 0.010 / .0005" 0.020 / .001"	mm / inch 0.0005 / .00002" 0.001 / .00005" 0.001 / .0001" 0.005 / .0005"
Functions:					
ON/OFF	●	●	●	●	
Zero set the display	●	●	●	●	●
Zero set the analog display	●	●	●		
Switch between mm/inch	●	●	●	●	●
Reversal of counting direction	●	●	●	●	●
Enter a numerical value					
Preset	●	●	●	●	
Data key	●				
Data via control instrument 2000sg	●	●	●		
ABS/REL-switchable	●	●	●	●	
Tolerance display	●		●	●	●
Dynamic measuring functions Min. Max. Max-Min (Tir)	●		●		●
Resolution switchable	●	●	●	●	●
Analog display	●	●	●	●	●
Analog value switchable		●	●	●	●
Lock key function	●		●	Optional	Optional
Data output USB	●	●	●		
Digimatic	●	●	●	●	●
Opto RS232C	●	●	●		●
Control output	●		●		
Protection class IP class acc. IEC 60529	IP54	IP54	IP54	IP54	IP54

Millimes 2100

► | The new Inductive Digital Comparator **Millimes 2100**. Tolerance monitoring is simplified with the color change in the background lit display. | ◀

Dynamic measuring functions:

- MAX / MIN for example, finding the reversal point
- MAX - MIN storing values for example when testing concentricity and flatness



Tolerance function:

clearly visual tolerance excess due to the change of color in the background lit display.



Universal SPS Interface

The choice is yours:
MarConnect Data output, choose between USB, Digimatic or RS232C



Control output can be connected to a SPS



Linearized, inductive **absolute measuring system**. Reference point is not lost when the instrument is switched off

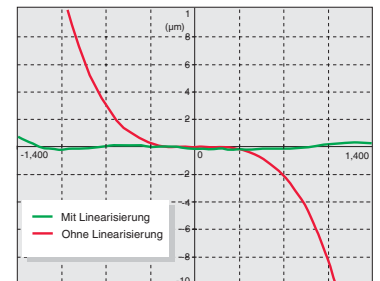

Code Initial	IP	International Protection
First Numeral	5	Dust protected
Second Numeral	4	Protection against splash water in all directions



Especially suited for use in a manufacturing environment. Waterproof: **protection class IP54** in accordance to IEC 60529

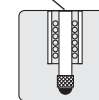

High precision rotary stroke bearings for a longer service life and higher capacity

Inductive Digital Comparator Millimess 2100 with background lit display

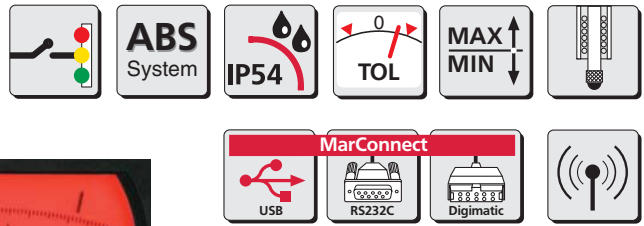

Features

Functions:

- ON/OFF
- RESET (zero setting the digital and analog displays)
- 0 - (set the analog display to zero)
- PRESET (enter any numerical values)
- DATA (data transmission)
- mm/inch-switchable
- Reversal of counting direction
- RANGE (switch the measuring range and resolution)
- ABS (reference to electrical zero point)
- MAX / MIN memory, e.g. ideal to search for the reversal point
- MAX-MIN e.g. testing concentricity and flatness

- TOL (entering tolerance)
- Tolerance band max. 2,8 mm
- LOCK: operating functions can be blocked via PC-Software
- Factor can be set / adjusted
- Linearized inductive absolute measuring system
- Measurement electronic is compensated for temperature
- Power supply via the mains power adapter
- MarConnect data output: choose either USB, OPTO RS232C, Digimatic

- Dial Comparator can be remotely operated via the interface (Opto RS232C)
- Control output compatible to Dial Comparators with limit contacts
- Operating and display unit (bezel) can be rotated through 280°
- Measuring force spring is interchangeable
- Lower stop is adjustable
- Protection class IP54 according to IEC 60529

- Operating temperature 5 - 40°C
- High contrast background lit LCD with 6.5 mm high digits
- Analog display has a 4 mm long pointer which ensures better visual perception, ideal when checking concentricity and flatness and also to search for the reversal point when measuring bores
- Supplied with: Mains adapter, rubber bellows and spanner for preliminary stroke setting

Technical Data

Measuring ranges switchable mm (inch)	Resolution switchable mm/inch	Display range of the analog display mm (inch)	Span of error* G within ±0.8 mm ±1.4 mm	Overtravel mm	Measuring force N	Order no. 230 V	Order no. 115 V
±1.0 (.04")	0.0005 / .00002"	± 0.015 (.0006")	1µm 2µm	1.8	0.7 - 0.9	4346200	4346201**
±1.4 (.055")	0.001 / .00005" 0.005 / .0002" 0.01 / .0005"	± 0.030 (.0015") ± 0.150 (.0060") ± 0.300 (.0150")					

* 1 digit in any zero position
** Includes Adapter Bush 940

Induktiver Feinzeiger 2000 / 2001

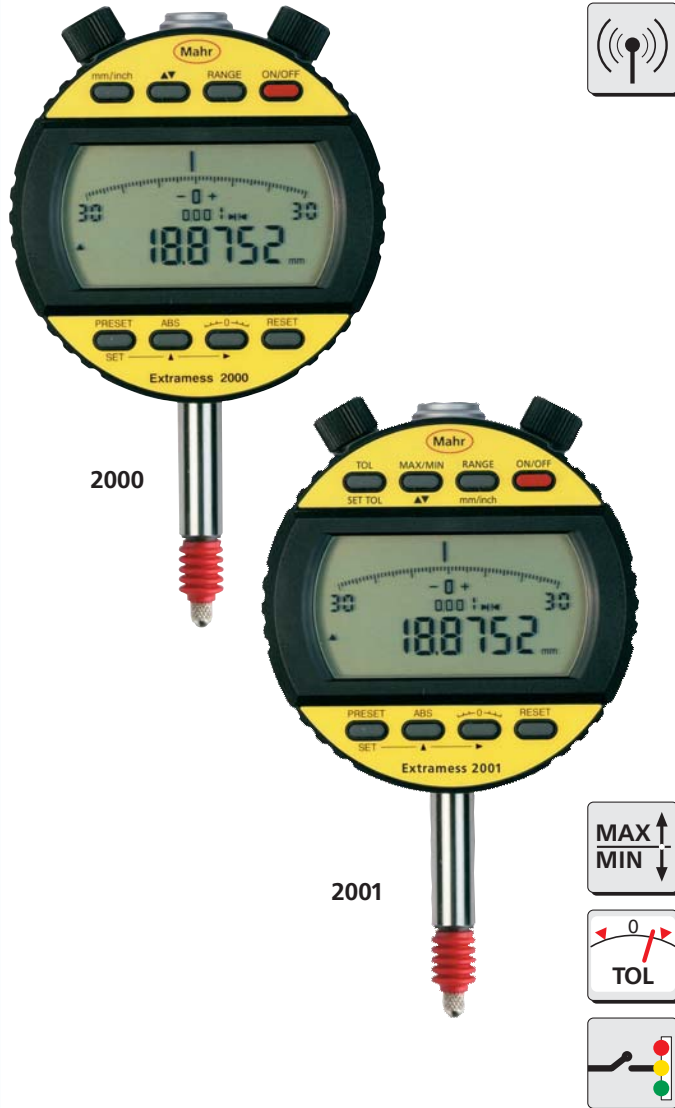
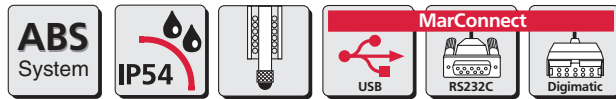

Features

Extramess 2000

Functions:

- ON/OFF
- RESET (Set the digital and analog display to zero)
- 0 - (Set analog display to zero)
- PRESET (enter any numerical values)
- mm/inch switchable
- Reversal of counting direction
- RANGE (Switch the measuring range and resolution)
- ABS (reference to electrical zero point)
- Battery charge level indicator
- Linearized inductive absolute measuring system
- Power supply via either the integrated rechargeable batteries (40 hrs.) or via the mains power adapter
- Rate measuring values are actualized 20 values/second
- MarConnect data output: choose either
USB
OPTO RS232C
Digimatic
- Comparator can be remotely operated via the interface
- High contrast LCD with 6.5 mm high digits. Analog display has a 4 mm long pointer for better visual perception, ideal when checking concentricity and flatness as well as search for the reversal point when measuring bores
- Operating and display unit (bezel) can be rotated 280°
- Measuring force spring is interchangeable
- Lower stop is adjustable
- Protection class IP54
- Operating temperature 5 - 40°C

Extramess 2001

- Features are identical to Extramess 2000, in addition:
 - MAX / MIN memory, e.g. ideal to search for the reversal point
 - MAX-MIN e.g. testing concentricity and flatness
 - TOL (entering tolerance)
 - Tolerance band max. 180 µm
- Block individual operating functions via Software (see accessories)
- Factor can be set / adjusted
- Control output compatible to Dial Comparators with limit contacts
- Supplied with: Mains adapter, rubber bellows and spanner for preliminary stroke setting

Technical Data

	Measuring ranges switchable mm (inch)	Resolution and readings mm/inch	Display range of analog display mm (inch)	Span of error* G µm	Over-travel mm	Meas. force N	Order no.	Order no.
							230 V	115 V
2000	1.8 (.07")	0.001 /.00005"	± 0.030 (.0015")	0.6	2.4	0.7 - 0.9	4346000	4346900 **
	1.8 (.07")	0.0005 /.00002"	± 0.015 (.0006")	0.6	2.4			
	0.8 (.031")	0.0002 /.00001"	± 0.006 (.0003")	0.3	2.9			
2001	1.8 (.07")	0.001 /.00005"	± 0.030 (.0015")	0.6	2.4	0.7 - 0.9	4346100	4346910 **
	1.8 (.07")	0.0005 /.00002"	± 0.015 (.0006")	0.6	2.4			
	0.8 (.031")	0.0002 /.00001"	± 0.006 (.0003")	0.3	2.9			

* 1 digit in any zero position

** Includes Adapter Bush 940

Inductive Digital Comparators 2100 / 2000 / 2001

- 1 Operating buttons
- 2 Display
- 3 Mounting shank
- 4 Measuring spindle
- 5 Contact point 901H
- 6 Connection or mains power supply
- 7 Data output
- 8 Rotatable operating and display unit (bezel)

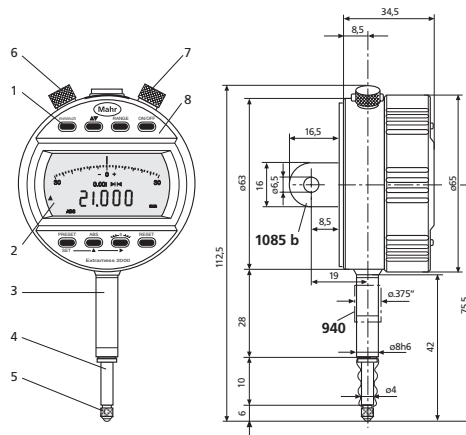

Control Instrument 2000sg



Features

- Remote control buttons: RESET, PRESET, RANGE*
- DATA-button for data transmission, option via foot switch
- Power is supplied by the Extramess
- Connect to the Extramess with the built-in control cable
- Data can be transferred to a PC with an optional data cable
- Splash waterproof according to IP54

Order no. 4346035

** Function is limited when used in conjunction with the 2100*

Accessories

Data Connection Cable USB (2 m)	2000 usb	4346023
Data Connection Cable Opto RS232C (2 m), SUB-D jack 9-pin	2000 r	4346020
Data Connection Cable Digimatic (2 m), flat plug 10-pin	2000 d	4346021
Cable to connect control output to an SPS	2000 sps	4346031

Measuring Force Springs

0.25 N	4346050
0.5 N	4346051
0.75 N	4882284
1.0 N	4346052
1.5 N	4346053
2 N	4346054
2.5 N	4346055

Manual Lifter with cable release	2000 h	4346010
Pneumatic Lifter	2000 p	4346011
Measuring Force Adjuster	2000 m	4346012
Mounting Lug Horizontal/Vertical	1085 b	4336310

Adapter Bush for adapting mounting shank 8h6 mm to inch bore .375"	940	4310103
---	------------	----------------

Additional Accessories Page

Contact Points	901-913	5-52
Special Holder	941	5-53

Accessories for Data Processing see Chapter 11

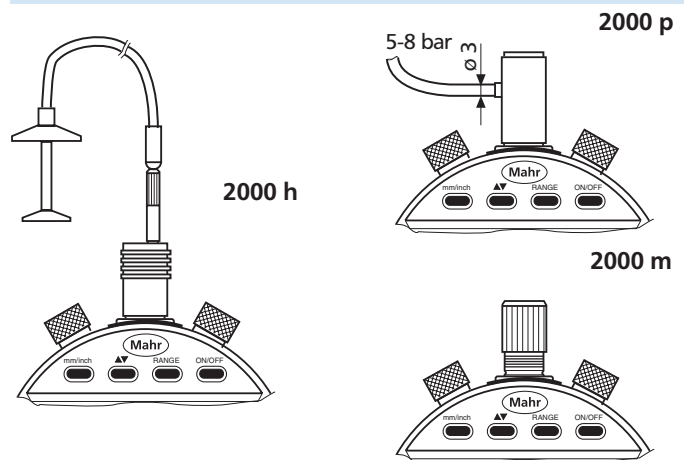

Inductive Digital Comparator μ Max μ m®

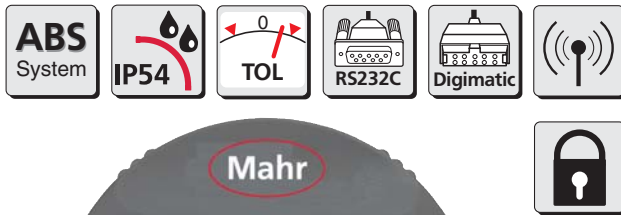

The most valueable electronic indicator for high production measurements.

Features

- Inch/Metric – operator selectable with switchable Inch resolution.
- Normal/Reverse Sensing
- Preset capabilities
- Optional Calibration Lockout feature.
- “Absolute” Transducer – no overspeed errors or constant re-zeroing. Federal’s unique transducer always remembers its location – even when power is off.
- High resolution digital readout and analog bar graph – digital display shows deviation from zero or a preset value.
- Lightweight, contamination resistant – ruggedly built to withstand hard use – gasketed case, crystal and stem assemblies resist fluid contamination.
- Calibratable – if ever needed – values remembered even after battery change.
- Data output – 2 popular formats – 7-pin recessed connector
- Auto power down – provides extremely low battery consumption, assuring long life from readily available commercial batteries.
- Unilateral Tolerances.
- Go/NoGo Display Feature.
- Increased resolution (0.0005 mm / 20 μ inch) for today’s demanding tolerances

Mode A:

Actual value + graphic display of tolerance



Mode B:

Go- No Go display

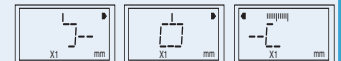

Technical Data

Dimensions mm/inch	A	B	C
	11.7 / .46"	24.1 / .95"	53.6 / 2.11"
	38 / 1.50"	57.2 / 2.25"	86.6 / 3.41"

For Contact Points please refer to pages 5-22, 5-27, 5-52 & 5-53.

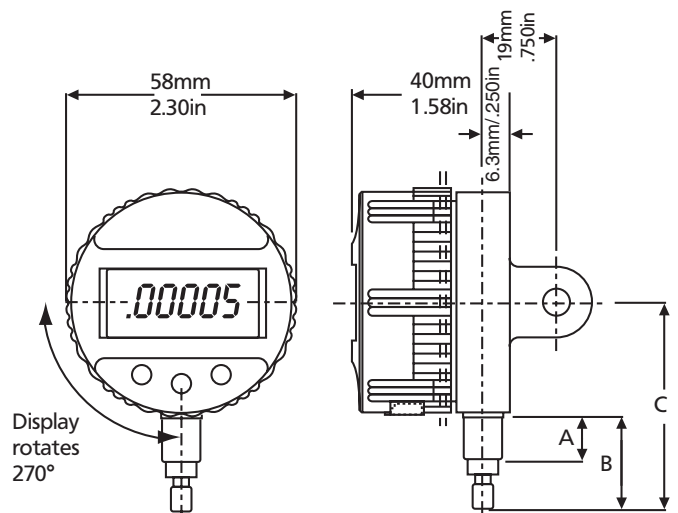

Inductive Digital Comparator μ Max μ m[®]

Technical Data

Range and Resolution

Display	Range	Standard Units		High Resolution Units	
		Resolution	Accuracy % of Digital Range	Resolution	Accuracy % of Digital Range
Inch	$\pm .040''$.00005" / .0001" / .0005" / .0002" / .001"	$\pm .5\%$ over $\pm .040''$ $\pm .25\%$ over $\pm .020''$.00002" plus same as standard	$\pm .5\%$ over $\pm .040''$ $\pm .25\%$ over $\pm .020''$
Metric	± 1.0 mm	0.001 / 0.002 / 0.005 / 0.010 / 0.020 mm	$\pm .5\%$ over ± 1.00 mm $\pm .25\%$ over ± 0.50 mm	0.0005 mm plus same as standard	$\pm .5\%$ over ± 1.00 mm $\pm .25\%$ over ± 0.50 mm

Specifications

Spindle Range	- .050" to + .060" (-1.28 mm to + 1.5 mm)
Repeatability	± 1 digit
Contact Point	(Normally furnished — PT-223) for .375" dia. stem, .250" long, radiused tip, 4-48 thread; (EPT-1037-W1) for 8 mm dia. stem, 6 mm long, radiused tip, M2.5 mm thread
Gaging Force	85-112 g/3-4 oz. (at center of spindle travel) Other gaging forces available — call Technical Assistance
Power	3 volt lithium coin cell (2 per unit, consumer type, CR 2450) Mahr Federal Model Number: EBY-1018
Battery Life	nine months normal usage or 3000 hours
Weight	approx. 170 g / 6 oz.
Display	Rotates through 270°
Operating Temperature	4° ... 50°C / 50° ... 130° F

Perpendicular μ Max μ m

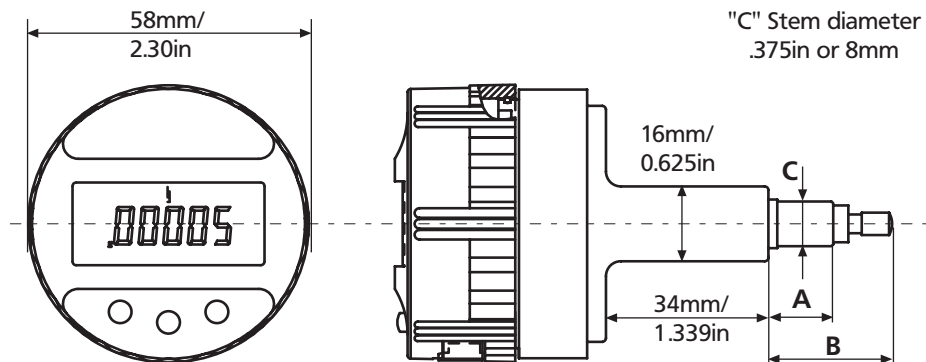

Dimensions

mm/inch	A	B
	11.7 / .46"	24.1 / .95"
	38 / 1.50"	57.2 / 2.25"

Inductive Digital Comparator μ Max μ m®

Ordering Information

μ Max μ m Model Number:

No Data Output EDI-

5 X X 0 X

Style	Range	Resolution	Code	Ratio	Code	Stem dia./L**	Code	Back	Code
"5" Series	± 1 mm / $\pm .040$ "	.001 mm / 50 μ inch		1:1	0	.375" / .46"	1	Lug (EBK-1010)	1
				4/5	1	.375" / 1.5"	2	Flat (EBK-1018)	2
						8 mm / .46"	3		
						8 mm / 1.5"	4		

With Data Output EDI-

X X X 0 X

Style	Range	Resolution	Code	Ratio	Code	Stem dia./L**	Code	Back	Code
High Resolution	± 1 mm / $\pm .040$ "	.0005 mm / 20 μ inch	2	1:1	0	.375" / .46"	1	Perpendicular (no back)	0
				4/5	1	.375" / 1.5"	2		
Standard Perpendicular	± 1 mm / $\pm .040$ "	.001 mm / 50 μ inch	3	Calibration Lockout, 1:1	2*	8 mm / .46"	3	Lug (EBK-1010)	1
					3*		4		
High Resolution Perpendicular	± 1 mm / $\pm .040$ "	.0005 mm / 20 μ inch	4	Calibration Lockout, 4/5	3*	8 mm / 1.5"	4	Flat (EBK-1018)	2

* Requires Calibration Access Key, EKY-1024 (sold separately)

** Diameter / Length

Note. Ask about our **EDS-X** models for special Setup Mode Lockout, MM/INCH Button Lockout, Calibration Lockout, Disable Sleep Mode and more

Accessories

	Order no.
Lug Back (Horizontal / Vertical)	EBK-1010
Flat Back	EBK-1018
Post Back	EBK-1012
Screw Back	EBK-1013
Back for Adjustable Mounting Brackets like AT-28 and AT-116 (slide sold separately)	EBK-1014
Adjustable Back (.5" slot x 1/4 - 20 thread)	EBK-1016
Mating Connector (7 pin)	ECN-1720
Output Cable to Digimatic	2001025
Serial output cable to DB-9 pin	SCB-4
Dust Cover	ECV-1307-W2
Calibration Access Key	EKY-1024
Spring – for lighter gaging force: 35 g / 1.2 oz.	SP-351

Maxum® III Digital Comparator

Features

- Features both digital display for accuracy and readability and unique fan analog display for trend and change
- User configurable in inch / metric units, normal / reverse sensing, resolution, analog scale, and tolerance setup & display
- Dynamic Capabilities: Min, Max, TIR, Hold, Reset
- Absolute Transducers - no overspeed errors. . . . no missed counts. . . . no missed readings
- Auto power down - provides extremely low battery consumption, assuring long life from readily available commercial batteries
- Data output - 3 formats - Maxum, serial, or digimatic
- Both integral and remote readout versions available
- Easily used on Snap Gages, Bore Gages, Comparator Stands, and Fixture Gages
- Special options available: setup mode or calibration lockout, remote external power, 4:5 ratio, 12 o'clock mounted integral transducer, integral vertical or horizontal lug back, 1.5, 2.0 or 3.0 inch stem length, and more. . . .
- IP54 protection
- Easy to select, order and operate!



Technical Data

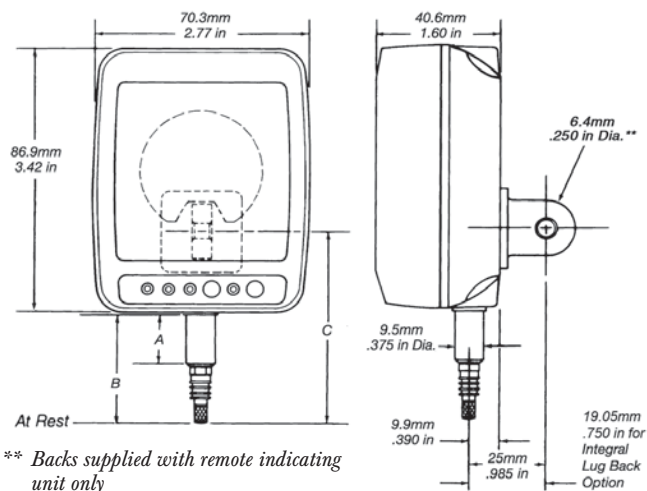

Easily designed into your applications . . . full-size Maxum® Indicator and accessories, tracing templates or CAD files available on request.

For short range indicators – Standard Stem Length (± 1.0 mm/ ± .040" range indicators)

A	B	C
17 mm/ .670"	36 mm/ 1.42"	63.5 mm/ 2.50"

For long range indicators – Standard Stem Length (± 1.99 mm/ ± .100" range indicators)

22 mm/ .87"	47 mm/ 1.84"	73 mm/ 2.87"
-------------	--------------	--------------

For both short and long range indicators – Long Stem Lengths

38 mm/ 1.5"	57 mm/ 2.25****	84.6 mm/ 3.33****
51 mm/ 2**	70 mm/ 2.75****	97.3 mm/ 3.83****
76 mm/ 3**	95 mm/ 3.75****	123 mm/ 4.83****

* Special Order Lengths

** Back supplied with remote indicating unit only

*** For long stem lengths add .220" to above lengths

Maxum® III Digital Comparator

Technical Data

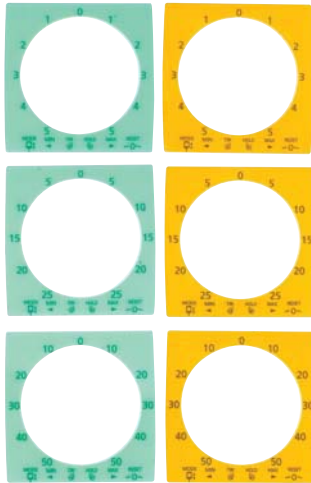

Description	Short Range	Long Range		
Digital range				
Standard	±1.00 mm/ ±.040"	±1.99 mm/ ±.100"		
Reduced	±0.199 mm/ ±.0199"	None		
Digital resolution	0.005 mm/ .0005"	0.005 mm/ .0005"		
Switchable	0.001 mm/ .0001" 0.001 mm/ .00005" 0.0005 mm/ .00002"	0.001 mm/ .0001"		
Analog range	5 or 25 or 50	25 or 50		
Analog resolution	0.01 mm/ .001"	0.01 mm/ .001"		
Switchable	0.005 mm/ .0005" 0.001 mm/ .0001"	0.005 mm/ .0005"		
Total spindle travel	3.04 mm/ .120"	6.35 mm/ .250"		
Pre-Travel*	0.3 mm/ .010"	1.06 mm/ .020"		
Over-Travel*	0.8 mm/ .030"	1.31 mm/ .030"		
Accuracy				
Standard range	0.5% of Total Range	0.35% of Total Range		
Reduced range	0.25% of Total Range	N/A		
Repeatability	±One Least Digit	±One Least Digit		
Gaging force	3 - 4 oz / 85 - 112 grams, preloaded			
Operation temperature	10° to 55°C / 50° to 130°F			
Storage temperature	-20° to 65°C / -4° to 149°F			
IP Rating	54			
Weight	approx. 385 g / 13.6 oz.			
Battery life	approx. 4000 hours			
Power	3.0 volt Lithium battery (type CR123A or equivalent) Mahr Federal Order Number: 2239138			
Contact point	(Normally furnished — PT-223) for 0.375" dia. Stem, 0.250" long, radiused tip, 4-48 thread; (EPT-1037-W1) for 8 mm dia. stem, 6 mm long, radiused tip, M2.5 thread.			
Stem length mm / <i>inch</i>	Stem diameter	Data output	Order no. Short range	Order no. long range
17 mm/ 0.670"	0.375"	No Output	2033101	2033102**
38 mm/ 1.50"	0.375"		2033103	2033104
17 mm/ 0.670"	8 mm		2033105	2033106**
38 mm/ 1.50"	8 mm		2033107	2033108
17 mm/ 0.670"	0.375"	Digital Output 6 pin (D, E1)	2033111	2033112**
38 mm/ 1.50"	0.375"		2033113	2033114
17 mm/ 0.670"	8 mm		2033115	2033116**
38 mm/ 1.50"	8 mm		2033117	2033118
17 mm/ 0.670"	0.375"	Digital Output with Hold / Reset 10 pin (E2)	2033121	2033122**
38 mm/ 1.50"	0.375"		2033123	2033124
17 mm/ 0.670"	8 mm		2033125	2033126**
38 mm/ 1.50"	8 mm		2033127	2033128

* dependent on standard or reduced range selected. Standard range shown.

** Long Range Indicator Stem Length is 0.870" / 22 mm

Maxµm® III Digital Comparator

Technical Data

Maxµm® III Remote Indicating Unit*

No Digital Output Port
 Digital Output -6 pin (D, E1)
 Digital Output with Hold & Reset -10 pin (E2)

Order no.

2033001
2033011
2033021



Supplied with Lug back

* Maxµm® III Remote Indicating Units are NOT compatible with traditional Remote Transducer models EAS-XXXX.

Maxµm® III Digital Transducer^①

Digital Transducers

Short Range

Long Range

Range	±1.00 mm/ ±.040"	±1.99 mm/ ±.100"
Total Spindle Travel	3.04 mm/ .120"	6.35 mm/ .250"
Pre-Travel**	0.3 mm/ .010"	0.5 mm/ .020"
Over-Travel**	0.8 mm/ .030"	

Gaging Force 3-4 oz / 85-112 grams, preloaded
 Operation Temperature 10° to 55°C/50° to 130°F
 Storage Temperature -20° to 65°C/-4° to 149°F

Contact Point (Normally furnished – PT-223) for **0.375"** dia. Stem, **0.250"** long, radiused tip, 4-48 thread; (EPT-1037-W1) for 8mm dia. Stem, 6mm long, radiused tip, M2.5 thread. 2033099 has PT-225 - .125" long.

** dependent on standard or reduced range selected. Standard range shown.

Transducer Type	Stem Length	Stem Diameter	Order no. Short Range	Order no. Long Range
-----------------	-------------	---------------	-----------------------	----------------------

Canister	17 mm/ 0.670"	0.375"	2033091	2033092^②
Canister	38 mm/ 1.50"	0.375"	2033093	2033094
Canister	17 mm/ 0.670"	8.0 mm	2033095	2033096^②
Canister	38 mm/ 1.50"	8.0 mm	2033097	2033098

Pencil	Body Diameter = 0.375"		2033099	—
--------	-------------------------------	--	----------------	---

Note: Cable length 4ft

① Digital Transducer models 203309X require an adaptor cable for use with traditional DEI-XXXXX Maxµm and Maxµm Plus Indicating Units.

② Long Range Indicator Stem Length is 0.870" / 22 mm.
 See Adaptor Cable selections as follows:

Adaptor Cables

Order no.

For DEI with 6 pin split connector (Short Range)	2239080
For DEI with 8 pin round connector (Long Range)	2239081

- Maxµm® and Maxµm Plus Transducers are available as Replacement Parts. Refer to Part Price List for Part Numbers and Pricing.
- Maxµm III Remote Indicating units sold separately from Digital Transducer.
- Any Digital Transducer may be used with a Maxµm III Remote Indicating unit.
- For English or Metric Contact Points visit pages 5-22, 5-27 and 5-52 thru 5-53.
- For alternate cable lengths or extension cables - call Mahr Federal's Technical Assistance Group.
- For special indicator options - call Mahr Federal's Technical Assistance Group.



Pencil



Canister

Maxµm® III Digital Comparator

Accessories

For Integral Maxµm® Indicators

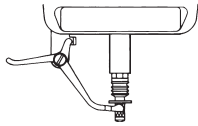

Lifting Levers¹⁾

Furnished with washer and longer contact point. Left Hand (shown)

Order no. EAS-1903*

Right Hand (not shown)

Order no. EAS-1904

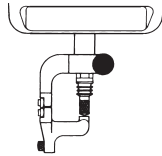

Right Angle Attachments

Lever Type (not shown)
(± .187" maximum range)

Order Model EAT-1034-W1

Spring Type (shown)
(± .060" maximum range)

Order Model EAT-1035-W1

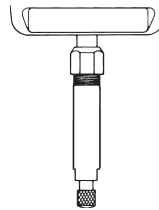

Auxiliary Plunger

3" long, .500" O.D.

Order no.

EAS-1912

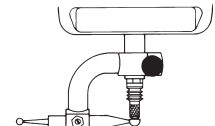

Hole Attachments

Short Lever (shown)
(1.0" pivot to contact)

Order Model EAT-1032-W1

Long Lever (not shown)
(1.87" pivot to contact)

Order Model EAT-1033-W1

¹⁾ (For use on .670" stem length only, DEI-XX1X1)

* Not for (±.100" / 1.99 mm)



Ox-Bow Lifting Lever

Order no.

LR-40

* Other Accessories shown are for .375" stem models. Equivalent types are available for most Maxµm models having 8mm stems. Adaptor Bushing (BU-197) may also allow 8mm stem indicators to be used with the above accessories. Full size Maxµm Indicator and accessories tracing templates are available on request.

Backs for Maxµm® Indicators and Remote Indicating Units (Supplied with mounting screws)

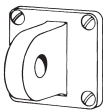

Lug Back (.250" hole)

Mounts horizontally or vertically.

Order no. EBK-1006

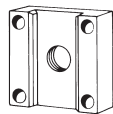

Adjustable Slide Back

(.500" slot, 1/4-20 thread)

Order no. EBK-1007

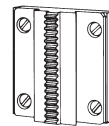

Rack Back

Fits SE-33 (shown) and SE-73.

Adjustable Mounting Block (not shown).

Order no.

EBK-1005

Replacement Screws

2-56 x .218"

Order no. ESW-1252

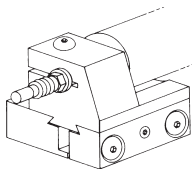

Rack Bracket (Shown mounted to SE-33 Adjustable Mounting Block.)

SE-33 and SE-73 Adjustable Mounting Blocks are available separately. SE-33 is supplied with hex-screw adjust. SE-73 is supplied with knob adjust.

Order Model EAD-1007-W1 (.375" I.D.)

Order Model EAD-1007-W2 (8 mm I.D.)

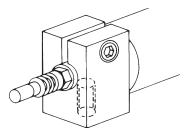

Square Bracket

(1/4-20 mounting thread)

Order Model AAD-67

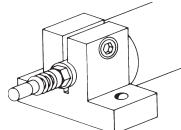

T Bracket

Flange mounted.





Order Model AAD-91

* Mounting Brackets shown are for .375" stem models. Equivalent types are available for most Maxµm models having 8 mm stems. Adaptor Bushing (BU-197) may also allow 8 mm stem indicators to be used with the above accessories. Full size Maxµm Indicator and accessories tracing templates are available on request.

Other Maxµm Accessories	Order no.
Data Output Cables for Maxµm III	
Serial Cable (6 pin to db9 pinF PC)	2239036
Serial Cable (10 pin to db9 pinF PC)	2239038
Digimatic Cable (6 pin to std 10 pin)	2239035
Digimatic Cable (10 pin to std 10 pin)	2239037
Send Data Footswitch used with Serial Cables above.	300-50
Mating Connectors — Maxµm III Models	
For 6 pin data output type (D, E1)	ECN-1521
For 10 pin data output type (E2)	ECN-1689
Remote Switch Assembly (for Hold/Reset)	
Handswitch	EAS-2867
Footswitch	EAS-2868
Splashcover for Maxµm III	ECV-1307-W1
Battery for Maxµm III	2239138
Overlay Kit for Maxµm III	2239040
Access Key (6 pin)	2240545
Access Key (10 pin)	2240547







Millimess. Dial Comparators

OVERVIEW

Models				
Metric	1000 A	1000 B	1002	1003
				
Measuring range	± 100 µm	± 50 µm	± 25 µm	± 50 µm
Readings	1 µm	1 µm	0.5 µm	1 µm
Dial style	100-0-100	50-0-50	25-0-25	50-0-50
Accuracy*	Factory standard	Factory standard	DIN 879-1	DIN 879-1
G _{ges}	2 µm	2 µm	0.6 µm	1.2 µm
G ^e	1.5 µm	1.5 µm	0.5 µm	1 µm
f _u	1 µm	1 µm	0.3 µm	0.5 µm
G ^t	0.7 µm	0.7 µm	0.4 µm	0.7 µm
r	0.5 µm	0.5 µm	0.3 µm	0.5 µm
Order no. Standard	4338000	4339000	4335000	4334000
Order no. Waterproof			4335005	4334005
Inch			1002 Z	1003 Z
Measuring range			± .0010"	± .0020"
Readings			.00002"	.00005"
Dial style			.001-0-.001	.002-0-.002
Accuracy*			Factory standard	Factory standard
G _{ges}			.000025"	.00006"
G ^e			.00002"	.00005"
f _u			.00001"	.000025"
G ^t			.000014"	.000035"
r			.00001"	.000025"
Order no. Standard			4335900	4334900
Order no. Waterproof			4335905	4334905

* Accuracy of 1004, 1010, 1010 Z, 1050 exceeds DIN 879-1

** Accuracy of 1110 N and 1150 N exceeds DIN 879-3

1003 XL	1004*	1010*	1050*	1110 N**	1150 N**
					
± 130 μm 2 μm	± 0.13 mm 5 μm	± 0.25 mm 0.01 mm	± 1.5 mm 0.05 mm	± 0.25 mm 0.01 mm	± 1.5 mm 0.05 mm
130-0-130	130-0-130	25-0-25	15-0-15		
DIN 879-1	Factory standard	Factory standard	Factory standard	Factory standard	Factory standard
2.4 μm	4 μm	8 μm	40 μm	12 μm	60 μm
2 μm	3.5 μm	7 μm	35 μm	6.5 μm	35 μm
1 μm	1 μm	2 μm	10 μm	3.5 μm	17 μm
1.4 μm	3 μm	4 μm	24 μm	5 μm	25 μm
1 μm	1 μm	2 μm	10 μm	0.5 μm	17 μm
4334001	4333000	4332000	4330000	4343100	4342100
4334006	4333005	4332005	4330005	4343105	4342105

1004 Z	1010 Z
± .0050"	± .0100"
.0001"	.0005"
.005-0-.005	.01-0-.01
Factory standard	Factory standard
.00012"	.0004"
.0001"	.00035"
.00003"	.0001"
.00005"	.00025"
.00003"	.0001"
4333900	4332900
4333905	4332905

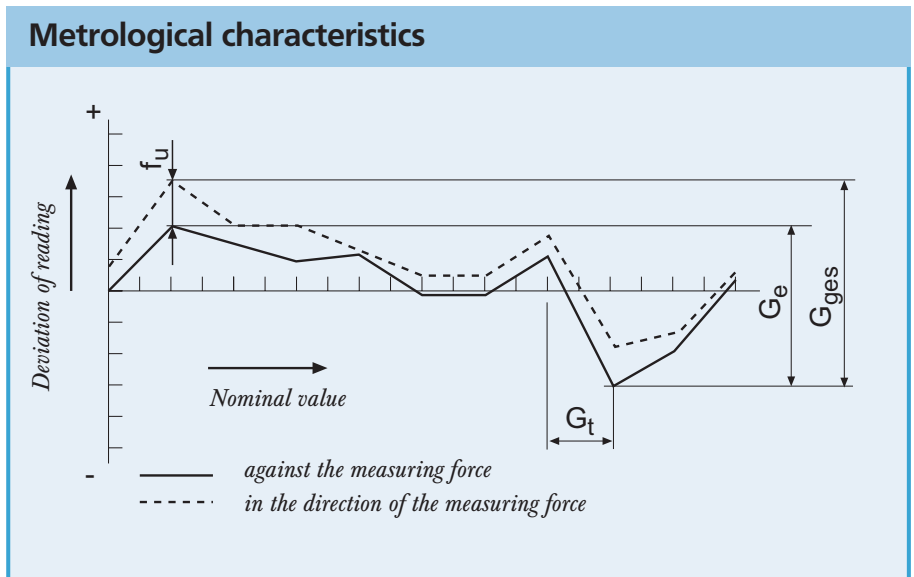

Millimess. Dial Comparators

OVERVIEW

Design Features

Box type protective housing

Constant measuring force

Lockable fine adjustment screw

Self contained movement, which is both quick and easy to remove and replace

Measuring spindle can be retracted with either a screw in cable release or with a lifting knob.

Mounting shank and measuring spindle are both made of hardened stainless steel

Measuring spindle is mounted in a high precision ball guide (Types 1000 / 1002 / 1003 / 1004) for minimal hysteresis

Insensitive to lateral forces (side play) acting on the measuring spindle

Maximum sensitivity and accuracy are ensured by the jeweled movement and in conjunction with the precision gears and pinions

Easy to read scale

Adjustable tolerance markers

Shockproof Mechanism

Measuring spindle within the measuring range

When the measuring range is exceeded the movement will be mechanically decoupled (shown in red)

SHOCK PROOF

Mechanical Dial Comparator Large Type Millimess

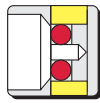

**SHOCK
PROOF**

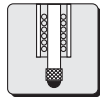

1000 A

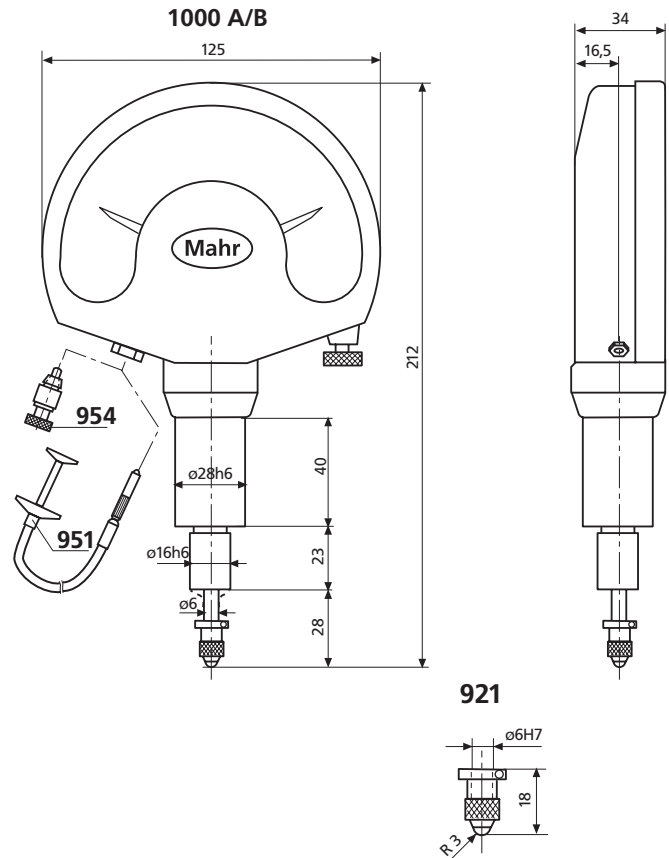

Features

- Large design
- Easy to read dial
- Shockproof movement
- Jeweled movement bearings
- Measuring spindle is mounted in a high-precision ball guide which precludes play
- Supplied with: Cable Release 951, case

Accessories

	Order no.
Contact Points with Steel ball	921 4362001
with Ruby ball	921 R 4362002
Cable Release to raise the measuring spindle	951 4372000
Lifting Knob for lifting the measuring spindle	954 4372030
Rubber Bellows to seal the open end of the measuring spindle	4338008
Additional Accessories	Page
Precision Stand	824 GT 8-13

Technical Data

Metric	Measuring range	Reading	Scale division	Over-travel	Measuring force	Order no.
1000 A	± 100µm	1 µm	1 mm	4 mm	3.5 N	4338000
1000 B	± 50µm	1 µm	2 mm	4 mm	3.5 N	4339000

Mechanical Dial Comparators



1002

DIN 879-1



1003

DIN 879-1



1004



1003XL

DIN 879-1



1003T**

DIN 879-1



Technical Data

Metric		Measuring range	Readings	Overtravel	Measuring force	Order no. Standard*	Order no. Waterproof**
1002	Supramess	± 25 µm	0.5 µm	2.8 mm	1 N	4335000	4335005
1003	Millimess	± 50 µm	1 µm	2.8 mm	1 N	4334000	4334005
1003	Millimess	± 50 µm	1 µm	2.8 mm	0.3 N	4334075	
1003	Millimess	± 50 µm	1 µm	2.8 mm	0.5 N	4334050	
1003	Millimess	± 50 µm	1 µm	2.8 mm	0.7 N	4334071	
1003	Millimess	± 50 µm	1 µm	2.8 mm	2 N	4334010	
1003	Millimess	± 50 µm	1 µm	2.8 mm	3 N	4334011	
1003 XL	Millimess XL	± 130 µm	2 µm	2.5 mm	1 N	4334001	
1004	Compramess	± 0.13 mm	5 µm	2.5 mm	1 N	4333000	4333005
1010	Zentimess	± 0.25 mm	0.01 mm	2.5 mm	1 N	4332000	4332005
1050	Dezimess	± 1.5 mm	0.05 mm	0.3 mm	1 N	4330000	4330005
Inch							
1002 Z	Supramess	± .0010"	.00002"	.11"	1 N	4335900	4335905
1003 Z	Millimess	± .0020"	.00005"	.11"	1 N	4334900	4334905
1004 Z	Compramess	± .0050"	.0001"	.10"	1 N	4333900	4333905
1010 Z	Zentimess	± .0100"	.0005"	.10"	1 N	4332900	4332905

* Incl. Plastic Case; Adapter 940 (for inch instruments only)

** IP54, Incl. Plastic Case, Splash Guard Cover 957, Rubber Bellows (only for 1002/1003/1004); Adapter 940 (for inch instruments only)

Mechanical Dial Comparators



1010



1050

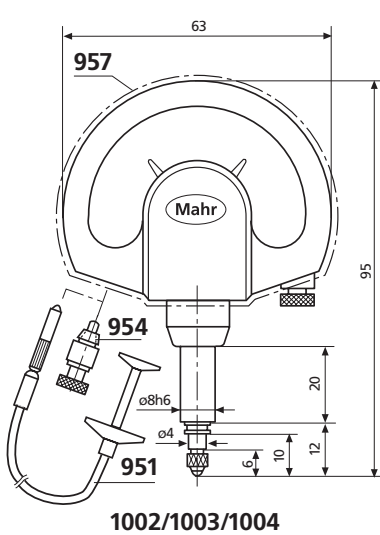

1002/1003/1004

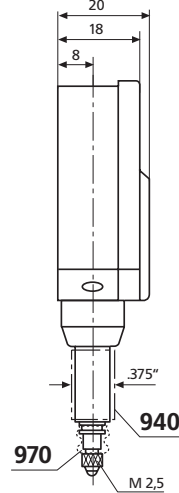

940

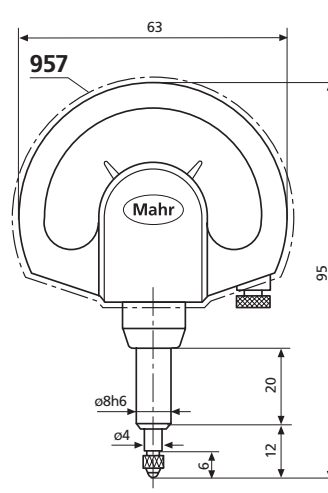

1010/1050

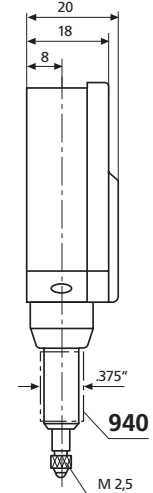

940

Accessories

	Order no.
Adapter Bush for adapting mounting shank 8h6 mm to inch bore .375"	940 4310103
Cable Release to raise the measuring spindle	951 4372000
Lifting Knob for lifting the measuring spindle	954 4372030
Splash Guard Cover	957 4373030
Rubber Bellows for 1002/1003/1004 to seal the open end of the measuring spindle	970 4334786
Mounting Lug to mount on mounting shank 8h6 mm	963 4375002

Additional Accessories	Page
Contact Points	901-913 5-52
Special Holder	941 5-52
Sensor Lever	943 5-53

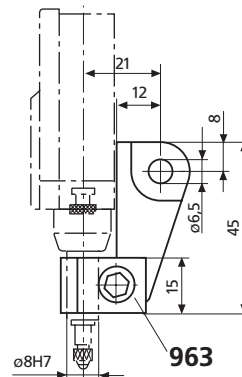

963

Mechanical Dial Comparators with limit contacts



Features

- Can be applied for example as tolerance control or as a precision contactor in automatic control systems
- Design features are identical with Mechanical Dial Comparators, but with the addition of adjustable limit contacts; made from high-grade precious metal
- Limit contacts are particularly well protected against vibration and mechanical overload

Technical Data

	Measuring range	Readings	Over-travel	Measuring force	Order no. Standard*	Order no. Waterproof**
Metric						
1110 N Elzentimess	± 0.25 mm	0.01 mm	2.3 mm	2 N	4343100	4343105
1150 N Eldezimess	± 1.5 mm	0.05 mm	0.3 mm	1.5 N	4342100	4342105

* Incl. Plastic Case, Setting Knob 953, Cable (1.2m)

** IP54, Incl. Plastic Case, Splash Guard Cover 957, Rubber Bellows (only for 1110)

Mechanical Dial Comparators with limit contacts

Electrical Specifications

	Contact uncertainty with non-inductive load of 10 mA/24V	max. contact rating	max. contact voltage	max. contact current
1110 N	+/- 1,5 µm	240 mW	24 V	100 mA
1150 N	+/- 7 µm			

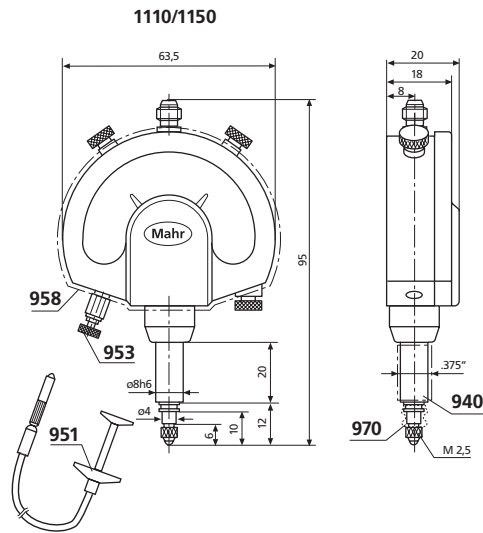
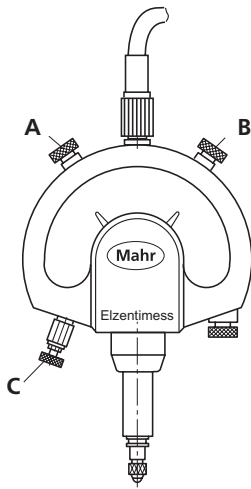

Wiring diagram

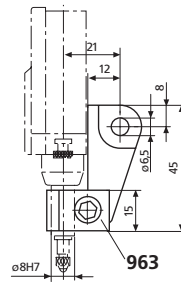
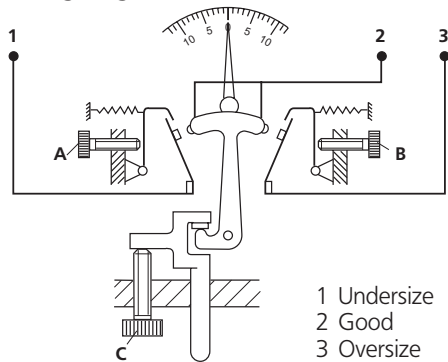

Accessories

	Order no.		Order no.
Connection Cable (1.2 m), axial	4345695	Splash Guard Cover	958 4373031
Connection Cable (5 m), axial	4345694	Rubber Bellows to seal the open end of the measuring spindle	970 4334786
Adapter Bush for adapting mounting shank 8h6 mm to inch bore .375"	940 4310103	Mounting Lug to mount on mounting shank 8h6 mm	963 4375002
Cable Release to raise the measuring spindle	951 4372000		
Setting Knob for setting the limit contacts without an additional setting standard	953 4372020	Additional Accessories	Page
Lifting Knob for lifting the measuring spindle	954 4372030	Contact Points	901-913 5-52
		Special Holder	941 5-52
		Sensor Lever	943 5-53

COMPLEX MEASURING TASKS BROUGHT STRAIGHT TO THE POINT. MILLIMAR



The latest information on MILLIMAR products can be found on our website:

www.mahr.com, WebCode 153

▶ | The requirements for electrical length measuring instruments are almost as broad as their scope of application. Reliability, precision as well as simple operation are the major demands, Millimar compact and column measuring instruments fulfill all these demands and requirements.

Millimar probes are the most influential components of a measurement chain. Their characteristics determine the quality of the entire measurement; depending upon the type of application we have the corresponding probe for your requirements. For example; a Millimar Inductive Probe: robust, versatile and has an attractive price, or a Millimar Incremental Probe which is ideal over a large measuring range and has a small linearity error over the entire measuring range.



► | Millimar. Electrical Length Measuring Instruments and Air Gaging

Overview	
Electrical Length Measuring Instruments	7- 2
<hr/>	
Overview	
Inductive Probes Program	7- 4
Millimar P1300	7- 6
Half-Bridge Probes, Mahr and Tesa compatibility, plug connector on the probe	
Millimar P2001 / P2004 / P2010 / P2104	7-10
High Linearity Probes: Mahr, Tesa, Marposs, Federal compatibility	
Millimar 1301 / 1303 / 1304 K / 1318	7-14
LVDT Probes, Mahr compatibility	
Millimar Lever Type Gage Heads EHE	7-16
Lever Probes, Federal compatibility	
Millimar 1340	7-20
High Precision Probe	
Millimar P1514 / P1526	7-21
Incremental Probe	
<hr/>	
Overview	
Evaluation Instruments	7-22
Millimar 1200 IC / 830 / 832 / C 1208 / C1216 / C 1245 / 1240	7-24
Compact Amplifiers	
Millimar S 1840	7-32
Column Amplifier	
Millimar X 1715 / X 1741	7-33
Measuring Interface Systems	
Millimar 1901 TA	7-35
Measuring Amplifier with analog output	
<hr/>	
Overview	
Air Gaging Instruments	7-36
Dimensionair® Air Gages	7-37
µDimensionair®	7-39
Millimar S 1840 PE	7-40
832 Dimensionair®	7-41
Millimar C 1208 PE / C 1245 PE	7-42
Air Plugs / Through Hole Plugs / Blind Hole / Counterbore Plugs	7-43
Air Gaging Instruments	7-46
Dimensionair® Air Rings	7-48

Millimar. Electrical Length Measuring Instruments

OVERVIEW

Evaluation Instruments



C 1216



C 1245



S 1840

- Compact, handy and simple to operate
- Extremely precise and easy to read due to the large clearly defined analog or digital display
- Single, sum and differential measurement; limit switches and extreme value memories
- Highly accurate, long term stability and insensitive to environmental influences
- Good zero stability even when changing the measuring range
- Short response time ideal for assessment of fast processes
- Analog or digital display
- Connect to a controller or a computer via the digital output
- Analog output (optional)

Inductive Probes

- Large linearity range, strong output signal and insensitive to interference
- Precise measuring spindle and lever, frictionless ball or spring bearing for the highest resolution with the lowest hysteresis
- Cable is plugged into the probe allowing quick and simple maintenance (P1300)
- Robust construction for use on the shop floor; further models for all applications are available.



P1300 M



P2004 M

Millimar. Electrical Length Measuring Instruments

APPLICATIONS WITH INDUCTIVE PROBES

Single measurement with one probe

Indicating instrument instantly displays the measured value.

- Used for all kinds of direct measurements on cylindrical and flat work pieces
- Applied in the same way as with digital / dial indicators, digital / dial comparators or test indicators

Thickness measurement

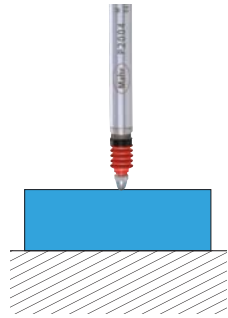

Radial run-out

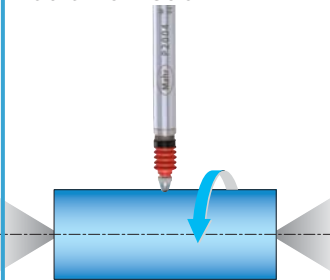

Axial run-out

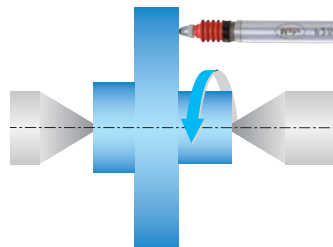

Sum measurement with 2 probes

Indicates the sum of deviation (total composite error) acquired from 2 probes irrespective of the form, support and concentricity deviation.

Thickness measurement

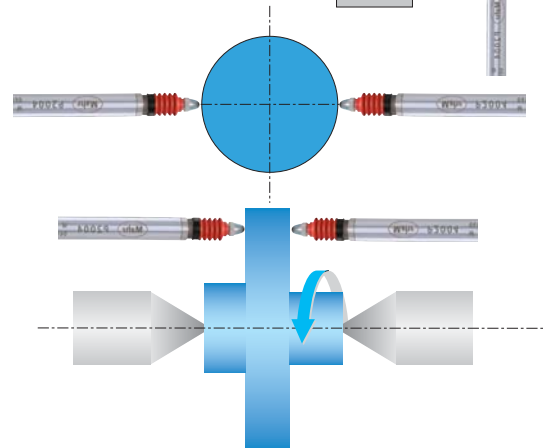
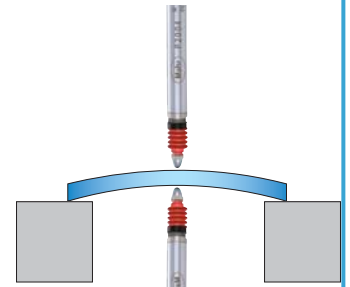

Difference measurement with 2 probes

Shows the difference between the measured values acquired by 2 probes irrespective of the absolute dimension of the test piece. This is particularly suitable for dimensional comparison of two test points.

Form measurement of wedges, cones

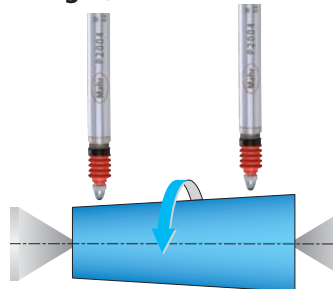

Height difference between 2 steps

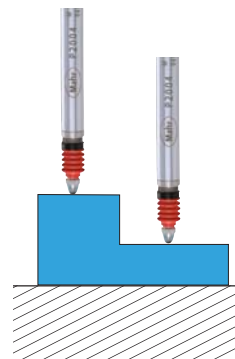

Perpendicularity measurement

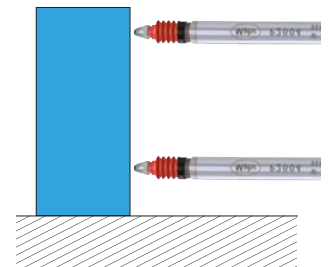

Concentricity measurement on 2 shaft diameters

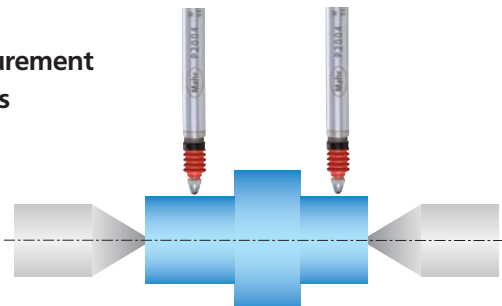

Millimar. Electrical Length Measuring Instruments

INDUCTIVE PROBE PROGRAM

P1300-Serie (Mahr-Half bridge)



P1300 A



P1300 B

- Available in Mahr and Tesa compatibilities
- Well-proven and established Mahr-Half Bridge technology
- Easy to service: cable and probe can be separated via the plug-in connector
- Simple to change to pneumatic lifting
- Measuring spindle runs in rotary stroke bearings

Page 7-6

P2000-Series



P2001



P2004



P210 A



P2104 A

- Available in all prominent compatibilities (Mahr, Mahr-Federal, Tesa, Marposs)
- Wide product spectrum; measuring ranges from 1 to 10 mm plus models with a compressed air (pneumatic) lifter or with vacuum retraction
- With rotary stroke bearings (except P2001)
- High linearity over the total measuring range
- Excellent electromagnetic shielding (EMC)
- All probes (except P2001) can be easily converted from axial to radial by mounting a slip on cap, included in the scope of supply

Page 7-10

1301 / 1303 / 1304 K / 1318 (Mahr-LVDT) / EHE-Series (Federal-LVDT)



1301



1303



1304 K



1318



EHE-2056

- Extremely robust in all operating conditions; measuring system is offset to guide and mounting shank
- Excellent clamping characteristics
- Measuring spindle runs in rotary stroke bearings (except 1318)
- Measuring spindle can be lifted with a cable release (1301/1303)
- Gaging pressure is less than 4g / .14 oz in either direction, with a change of less than 0.1 g per 25 μm / .0001" of contact travel and linearity of 0.1% over the full range $\pm 0.250 \text{ mm} \pm .010''$, also clutch-mounted contact swivels through 280° arc for easy positioning (EHE-Series)

Page 7-14

1340 Mahr High Precision Probe



1340

- To obtain the best results use in conjunction with Millitron 1240
- Unprecedented measuring accuracy and minimum linearity error < 0.01 %, i.e. 0.4 μm over the total measuring range

Page 7-20

General Technical Data of Inductive Probes

The measuring principle of inductive probes is based on the change of position of the magnets conductive core moving within a coil system, generally this is distinguished between a half bridge and LVDT's.

The Mahr P2000 series of probes applies a high linear, patented VLDT transducer which is similar to an LVDT transducer. This also operates according to a differential transformer principle.

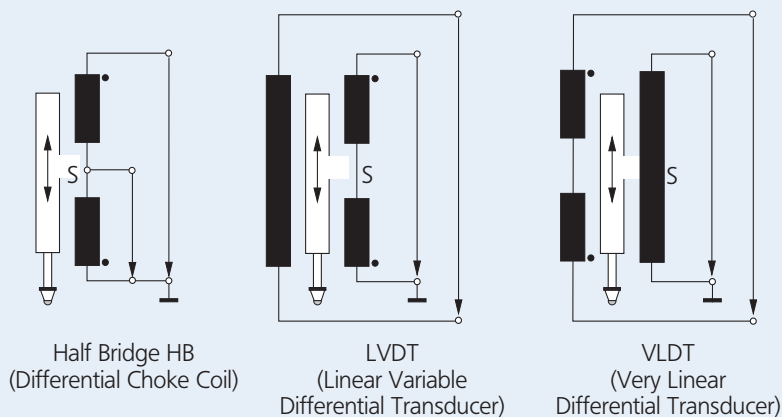

Electrical specification of various compatibilities

		Type	Mahr	Tesa	Marposs	Mahr-Federal
Carrier frequency	KHz		19.4	13	7.5	5
Sensitivity	mV/V/mm	P2001 P2004 P2104	192	73.75	115	78.74
		P1300	192	73.75	—	—
		1301 1303 1304 K 1318	192	—	—	—
		P2010	19.2	29.5	11.5	7.874
Amplitude	V _{eff}		5	3	3.5	2

Schematic drawings of Mahr input amplifiers according to the various compatibilities

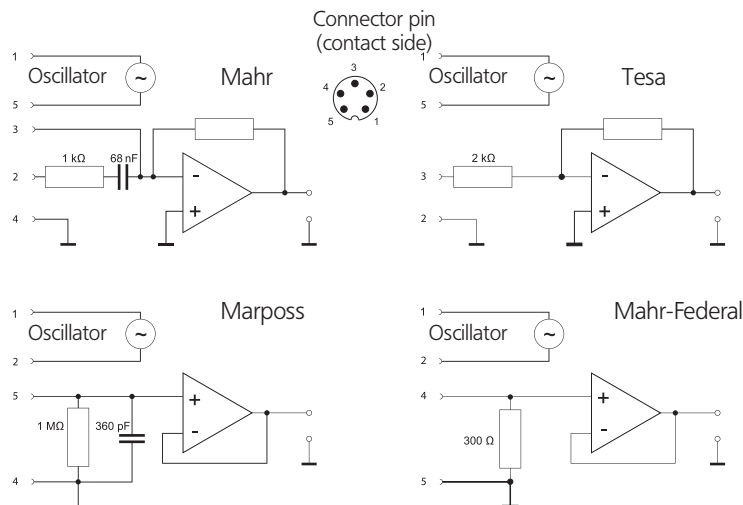

Millimar. The Plug and Play Probe

THE INDUCTIVE PROBE MILLIMAR P1300

▶ | The Plug and Play Probe: Cable and probe can be separated with the plug-in connector. High linearity due to sensitivity compensation in the probe. | ◀

High linearity due to the probe being able to compensate sensitivity.

Pneumatic Lifter can be fitted to any standard probe (with standard accessories). Simply fasten and unfasten an air hose.



Rotary stroke bearings thus insensitive to lateral forces acting upon the spindle

Especially suited for use in critical manufacturing environments. Probe and cable connector are water proof **IP64** according to IEC 60529



Sealing bellow is made from Viton which has a **excellent chemical resistance**.



Code Initial	IP	International Protection
First Numeral	6	Dust tight
Second Numeral	4	Protected against splash water from all directions



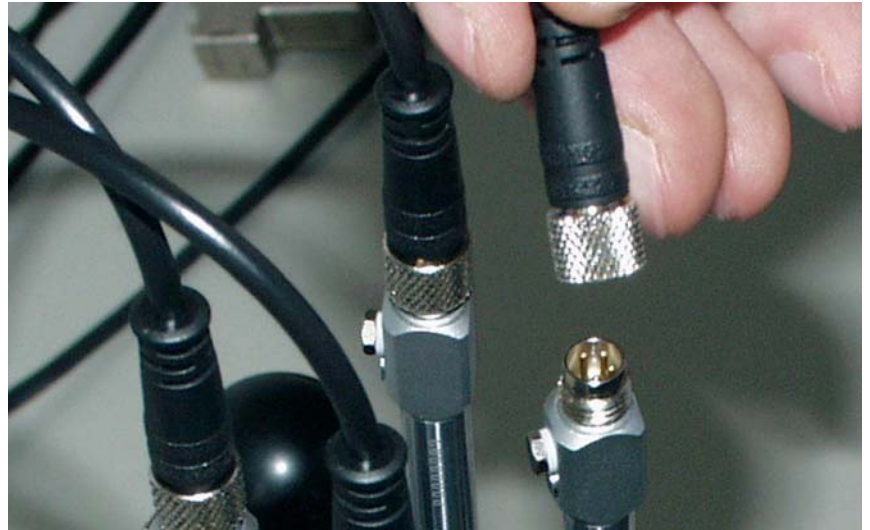

Extremely easy to service

Cable and probe can be separated via the plug-in connector.



Advantages of a probe with a plug-in connector:

Service incident	P1300	Standard Probe
<p>Cable break</p> 	<p>Only the cable has to be replaced.</p> <p>Advantage:</p> <ul style="list-style-type: none"> a) Shorter downtime of manufacturing equipment as the probe does not need to be newly installed and adjusted. b) Inexpensive, as only the cable has to be replaced and not the complete probe. 	<p>The complete probe must be removed from the fixture and replaced.</p> <p>Disadvantage:</p> <ul style="list-style-type: none"> a) Longer downtime as the probe must be newly installed, set-up and adjusted. b) Expensive as the complete probe must be replaced.
<p>Defective probe e.g. collision with workpiece</p> 	<p>Only the probe has to be replaced.</p> <p>Advantage:</p> <p>The cable does not need to be removed from the cable guide or the cable harness</p>	<p>The complete probe including the cable must be replaced.</p> <p>Disadvantage:</p> <p>The cable must be dismantled from the cable guide or the cable harness.</p>

Inductive Probe Millimar P1300 M / T Half Bridge

Features

- Supplied with:
Inductive Probe P1300
Connection cable 2.5 m
Screwed sealing plug
Hose connector for compressed air
Open-ended spanner
Operating instructions

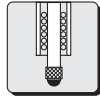

Cable and probe can be separated with the plug-in connector.



Technical Data

Probe type	P1300 MA	P1300 TA	P1300 MB	P1300 TB
Measuring range	± 2.0 mm / ± 0.079"			
Distance of lower stop ¹⁾	- 2.2 ... 0 mm / - 0.09 ... 0"			
Distance of upper stop ¹⁾	+ 2.2 ... 4.4 mm / + 0.09 ... 0.173"			
Lifter/Retraction	Vacuum Lifter (Standard option)		Compressed Air Retraction (max. 1 bar)	
Measuring force at electrical zero point	0.75 N / ± 0.15 N ²⁾		depending upon air pressure	
Increase in measuring force	0.3 N / mm		-	
Sensitivity deviation	0.3 %			
Repeatability f _w	0.1 µm / 4 µin			
Hysteresis f _u	0.5 µm / 20 µin			
Linearity deviation with revised sensitivity				
within range ± 0.5 mm	0.4 µm / 16 µin	1.0 µm / 40 µin	0.4 µm / 16 µin	1.0 µm / 40 µin
within range ± 1.0 mm	1.5 µm / 60 µin	3.0 µm / 120 µin	1.5 µm / 60 µin	3.0 µm / 120 µin
within range ± 2.0 mm	3.0 µm / 120 µin	not specified	3.0 µm / 120 µin	not specified
Protection class according to IEC 60529	IP64			
Length of cable	2.5 m / 8 ft (detachable)			
Compatibility - Half Bridge	Mahr	Tesa	Mahr	Tesa
Order no.	4400180	4400190	4400181	4400191

¹⁾ Relative to the electrical zero point. Adjustable; lower and upper stops are simultaneously adjusted

²⁾ Measuring force springs are interchangeable, following measuring force springs are available (0.25; 0.5; 1; 1.25; 1.5 N)

Inductive Probe Millimar P1300 M / T Half Bridge

- 1 Connection jack for an evaluation instrument
- 2 Connecting plug for the probe
- 3 Socket
- 4 Screw sealing plug SW 4.6
- 5 Hose connector for compressed air (external diameter 3 mm)
- 6 Mounting shank
- 7 Locking nut
- 8 Sealing bellows
- 9 Contact point 901 H
- 10 Preferred clamping area

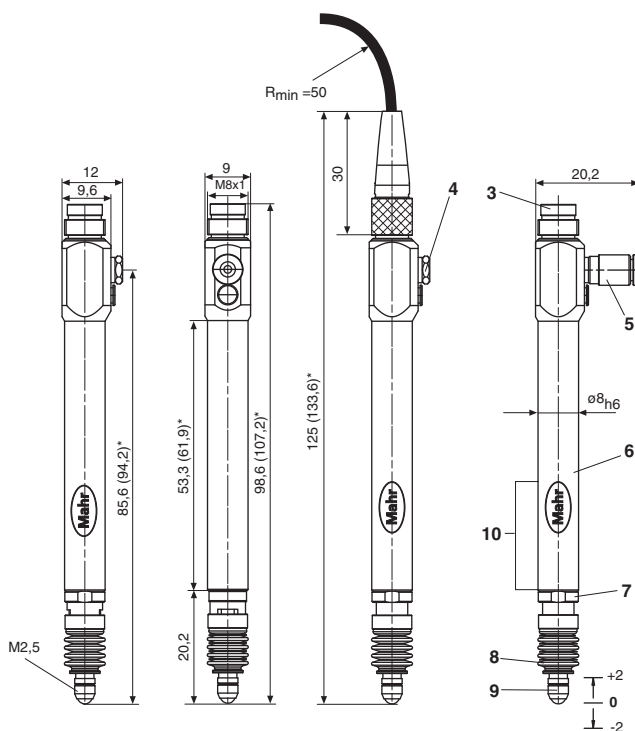
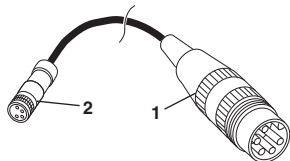

* Values shown in brackets apply to Tesa-compatibility

Individual Components and Accessories P1300



P1300 .. A



Connector for the air hose (90°)



Connection cable 2.5 m / 8 ft



P1300 .. B

Order no.

P1300 MA without cable	4400182
P1300 MB without cable	4400183
P1300 TA without cable	4400192
P1300 TB without cable	4400193
Hose connector for compressed air 90°	4400238
Cable for P1300 2.5 m / 8 ft	4885220
Cable for P1300 5 m / 16 ft	4885259
Cable for P1300 10 m / 32 ft	4885260
Sealing bellows for	
P1300 .. A	7021546
P1300 .. B	7028220

Order no.

Measuring force springs¹⁾ for P1300 .. A	
0.25 N	7026827
0.50 N	7026827
0.75 N	7026828
1.00 N	7026849
1.25 N	7025579
1.50 N	7025505

¹⁾ All measuring forces (except 0.25 N) including the sealing bellows have a measuring spring force of ca 0.25 N at zero point.

Inductive Probe Millimar P2000-Series

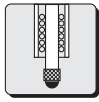

Technical Data

Probe type	P2001	P2004	P2004 A	P2004 B
Measuring range	± 0.5 mm / ± 0.020"		± 2.0 mm / ± 0.079"	
Distance of lower stop ¹⁾	–		- 2.2 ... 0 mm / -0.09 ... 0"	
Distance of upper stop ¹⁾	–		2.2 ... 4.4 mm / 0.09 ... 0.173"	
Lifter/Retraction	–	–	Vacuum lifter	Compressed air (max. 1 bar)
Measuring force at the electrical zero point	0.75 N ± 0.15 N	0.75 N ²⁾ ± 0.15 N	0.75 N ²⁾ ± 0.15 N	depending on air pressure
Increase in measuring force	0.1 N / mm	0.2 N / mm	0.2 N / mm	–
Sensitivity deviation	0.3 %		0.3 %	
Repeatability f_w	0.15 µm / 6 µin		0.1 µm / 4 µin	
Hysteresis f_u	0.2 µm / 8 µin		0.5 µm / 20 µin	

Linearity deviation with corrected sensitivity

within range ± 0.1 mm	0.6 µm		–	
within range ± 0.5 mm	1.5 µm/ 60 µin		0.4 µm/ 16 µin	
within range ± 1.0 mm	–		1.5 µm/ 60 µin	
within range ± 2.0 mm	–		3.0 µm/ 120 µin	
Protection class according to DIN VDE 0470 Part 1 / IEC 60529	IP40		IP64	
Cable length	2.5 m / 8 ft ³⁾		2.5 m / 8 ft ³⁾	

Order no.	P2001	P2004	P2004 A	P2004 B
Compatibility - Mahr	5323040	5323010	5323020	5323030
Compatibility - Tesa	5323041	5323011	5323021	5323031
Compatibility - Marposs	5323043	5323013	5323023	5323033
Compatibility - Federal	5323044	5323014	5323024	5323034

¹⁾ Relative to the electrical zero point. Adjustable; lower and upper stops are simultaneously adjusted

²⁾ Measuring force springs are interchangeable, additional measuring force springs are available (0.25; 0.5; 1; 1.25; 1.5 N)

³⁾ Extension cables are available, see accessories

Inductive Probe Millimar P2000-Series

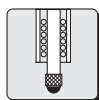

Technical Data

Probe type	P2010 A	P2010 B	P2104 A	P2104 B
Measuring range	± 5.0 mm / ± 0.197"		± 2.0 mm / ± 0.079"	
Distance of lower stop	- 5.3 mm / - .20"	- 5.3 mm / - .20"	- 2.2 ... 0 mm / -0.09 ... 0" ¹⁾	
Distance of upper stop	+ 5.3 / + .20"	+ 5.3 / + .20"	8.4 ... 10.4 mm / -0.33 ... 0.41" ¹⁾	
Lifter/Retraction	Vacuum lifter	Compressed air (max. 1 bar)	Vacuum lifter	Compressed air (max. 1 bar)
Measuring force at the electrical zero point	0.75 N ± 0.15 N ²⁾	depending on air pressure	0.75 N ± 0.15 N ²⁾	depending on air pressure
Increase in measuring force	0.1 N / mm	-	0.1 N / mm	-
Sensitivity deviation	0.3 %		0.3 %	
Repeatability f_w	0.2 µm / 8 µin		0.2 µm / 8 µin	
Hysteresis f_u	1 µm / 40 µin		0.5 µm / 20 µin	

Linearity deviation with corrected sensitivity

within range ± 0.5 mm	-	0.5 µm / 20 µin
within range ± 1.0 mm	-	2.0 µm / 80 µin
within range ± 2.0 mm	4.0 µm / 160 µin	4.0 µm / 160 µin
within range ± 5.0 mm	20.0 µm / 800 µin	-
Protection class according to DIN VDE 0470 Part 1 / IEC 60529	IP64	
Cable length	2.5 m / 8 ft ³⁾	2.5 m / 8 ft ³⁾

Order no.	P2010 A	P2010 B	P2104 A	P2104 B
Compatibility - Mahr	5324020	5324030	5324070	5324080
Compatibility - Tesla	5324021	5324031	5324071	5324081
Compatibility - Marposs	5324023	5324033	5324073	5324083
Compatibility - Federal	5324024	5324034	5324074	5324084

¹⁾ Relative to the electrical zero point. Adjustable; lower and upper stops are simultaneously adjusted

²⁾ Measuring force springs are interchangeable, additional measuring force springs are available (0.25; 0.5; 1; 1.25; 1.5 N)

³⁾ Extension cables are available, see accessories

Inductive Probe Millimar P2000-Series

P2001

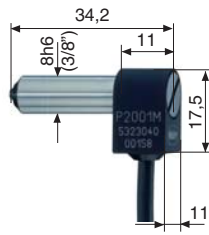

P2004

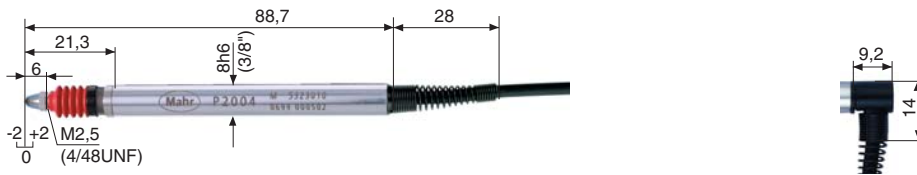

With the supplied slip-on cap, the cable can be flexed to 90° (vertical to horizontal)

P2004 A / P2004 B

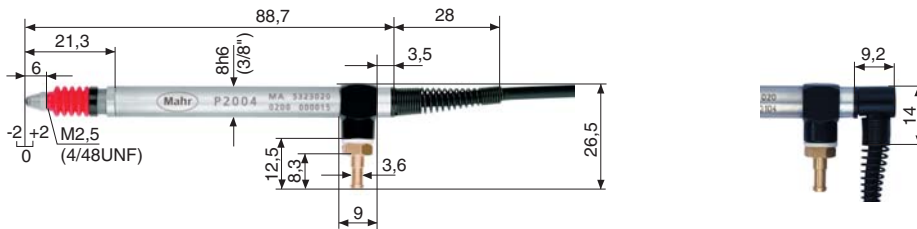

With the supplied slip-on cap, the cable can be flexed to 90° (vertical to horizontal)

P2010 A / P2010 B

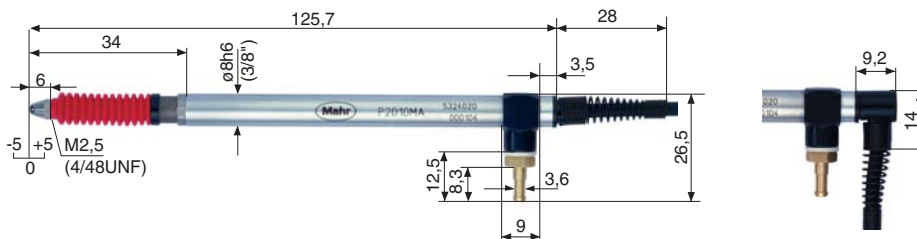

With the supplied slip-on cap, the cable can be flexed to 90° (vertical to horizontal)

P2104 A / P2104 B

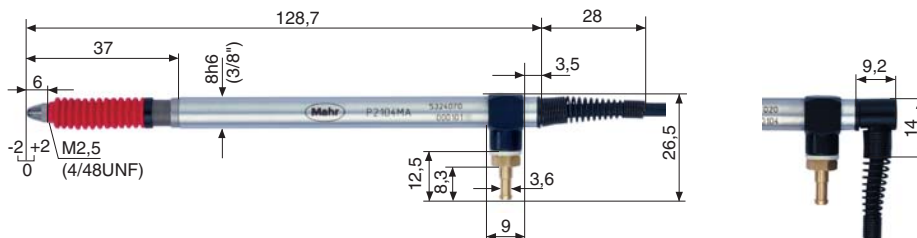

With the supplied slip-on cap, the cable can be flexed to 90° (vertical to horizontal)

Values shown in brackets apply to Federal-compatibility

Accessories

Extension cables		Mahr M	Tesa T	Marposs U	Mahr Federal F
Length	Description	Order no.	Order no.	Order no.	Order no.
2.5 m / 8 ft	C 2025	5323130	5323131	5323133	5323134
5 m / 16 ft	C 2050	5323140	5323141	5323143	5323144
7.5 m / 24 ft	C 2075	5323150	5323151	5323153	5323154
10 m / 32 ft	C 2100	5323160	5323161	5323163	5323164

Order no.		Order no.	
Measuring force springs¹⁾ for P2004 and 2004 A		Measuring force springs¹⁾ for P2010 A	
0.25 N	7026827	0.25 N	7028212
0.50 N	7026827	0.50 N	7028212
0.75 N	7026828	0.75 N	7027764
1.00 N	7026849	1.00 N	7028213
1.25 N	7025579	1.25 N	7028214
1.50 N	7025505	1.50 N	7028215
<i>1) All measuring forces (except 0.25 N) include the sealing bellows have a measuring spring force of ca. 0.25 N in zero position.</i>		<i>1) All measuring forces (except 0.25 N) include the sealing bellows have a measuring spring force of ca. 0.25 N in zero position.</i>	

Order no.		Order no.	
Measuring force springs¹⁾ for P2104 A		Sealing bellows for	
0.25 N	7028212	2004, 2004 A	7021546
0.50 N	7027764	2004 B	7028220
0.75 N	7028213	2010 A, 2104 A	7027758
1.00 N	7028214	2010 B, 2104 B	7028221
1.25 N	7028215		
<i>1) All measuring forces include the sealing bellows</i>			

Pneumatic Lifter 1340/1	for connection with 1 Probe	5313420
Pneumatic Foot Switch 1340/1F	for connecting max. 4 Probes, types 1340, P2004xA, P2010xA, P2104xA, 1300 A, 1310 A	5313419

Temperature specifications

Temperature coefficient ftT	0.15 $\mu\text{m} / ^\circ\text{C}$
Working temperature range	+ 10 ... + 55° C (+ 50 ... + 131° F)
Operating temperature range	- 10 ... + 80° C (+14 ... + 176° F)
Information regarding chemical resistance	Resistant against oil, gasoline (petrol), water, alipate. Moderate against acids, alkaline solutions, solvents, ozone

Inductive Probe Millimar 1301 / 1303 / 1304 K / 1318

M

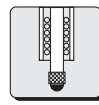
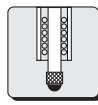

Technical Data

Probe type	1301	1303	1304 K	1318
Measuring range	± 1.0 mm / ± 0.039"		± 1.0 mm / ± 0.039"	-0.3.+1.0 mm/-0.012.+0.039"
Distance of lower stop ¹⁾	-1.1 ... 0 mm / -0.043 ... 0"		1.1 mm / -0.043"	- 0.37 mm / -0.0146"
Distance of upper stop ¹⁾	+2.7 mm / +0.106"		+1.1 mm / +0.043"	+ 1.6 mm / +0.063"
Lifter/Retraction	Cable release		-	-
Measuring force at the electrical zero point	0.75 N ± 0.15 N		0.75 N ± 0.15 N	0.25 N ± 0.05 N
Increase in measuring force	0.4 N / mm		0.15 N / mm	0.04 N / mm
Sensitivity deviation	0.5 %		1.0 %	0.5 %
Repeatability f _w	0.1 μm / 4 μin		0.15 μm / 6 μin	0.03 μm / 1.2 μin
Hysteresis f _v	0.2 μm / 8 μin		0.2 μm / 8 μin	0.5 μm / 20 μin
Linearity deviation with corrected sensitivity				
within range ± 0.3 mm	-		-	0.9 μm / 36 μin
within range ± 0.5 mm	0.5 μm / 20 μin		1.0 μm / 40 μin	-
within range ± 1.0 mm	2.0 μm / 80 μin		4.0 μm / 160 μin	-
Protect. class acc. to IEC 60529	IP64		IP62	IP50
Cable length	1.5 m / 5 ft ²⁾			
Compatibility - Mahr	LVDT			
Order no.	5313010	5313030	5313049	5313180

¹⁾ Relative to the electrical zero point

²⁾ Extension cables are available, see accessories

Inductive Probe Millimar 1301 / 1303 / 1304 K / 1318

M

1301

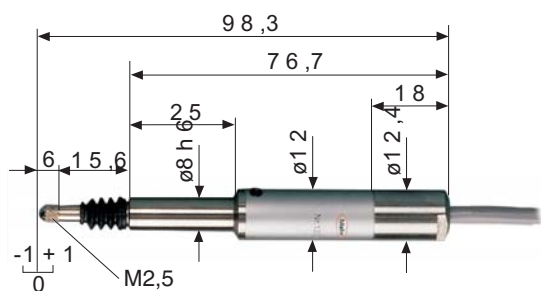

1303

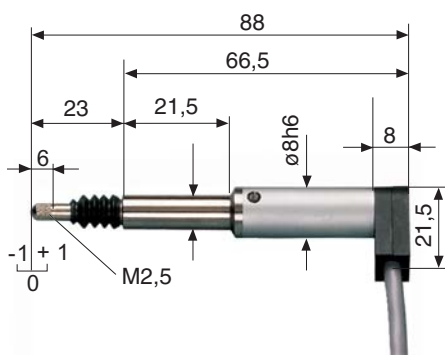

1304 K

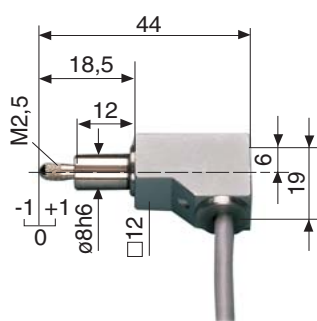

1318

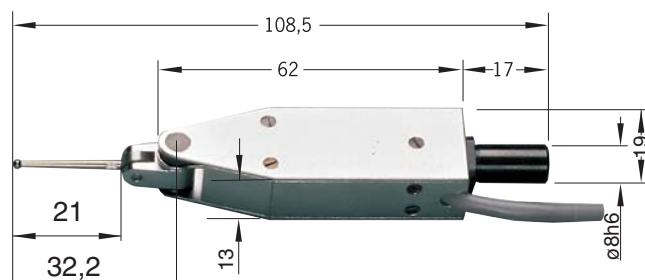

Accessories

	Description	Order no.	
Extension Cables for 1301 / 1303 / 1304 K / 1318	1288/1	1 m / 3 ft	5312881
	1288/2,5	2.5 m / 8 ft	5312882
	1288/5	5 m / 16 ft	5312885
	1288/7,5	7.5 m / 24 ft	5312887
	1288/10	10 m / 30 ft	5312889
Cable Release for 1301 / 1303	1399		5313990
Styluses for 1318 with carbide ball	d = 2 mm; L = 21 mm*		3005223
	d = 0.5 mm; L = 21 mm		7003901
	d = 1 mm; L = 21 mm		7003902
	d = 3 mm; L = 21 mm		7003903
Styluses for 1318 with ruby ball	d = 2 mm; L = 21 mm		8004231

* Supplied with 1318

Lever Type Gage Heads

F



EHE-2056

Features

- Clutch-mounted contact swivels through 280° arc for easy positioning
- Linearity – 0.1% over full range of ± 0.250 mm / ± 0.010 "
- Gaging pressure less than 4 g / .14 oz. in either direction, with a change of less than 0.1 gram per 25 μ m / .001" of contact travel. Special gaging pressures available. Contact Mahr Federal Technical Assistance
- Repeatability better than 0.1 μ m / 4 μ in
- Cable length – 1.2 m / 4 ft
- Miniature models include the same powerful features as standard sized Lever Type Gage Heads

For use on test stands, surface plate work, or where light pressure is needed.

Automatic Cosine Error Compensation

Angle "A"	Correction Factor
10	.985
20	.940
30	.866
40	.766
50	.643
60	.500

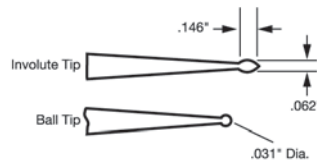

Involute tip (normally furnished) automatically corrects for cosine error when finger is at an angle up to 20°. Simplifies "reach over" jobs.

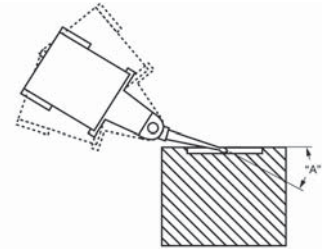

When exceeding 20°, use ball tip contact and table above. With multiplier function, 832F & 1840F Amplifiers can correct for cosine error.

Accessories

Adaptor to mount EHE-2048 on Model 2400 Stand

Clamp for mounting EHE-2048 on model 2300 Stand

Accessories kit for EHE-2048. Includes EAM-1071, CP-116, EPT-1013, two rectangular holding bars and a holding rod

Replacement tip, 1.6 mm/ .062" dia. steel ball

Replacement tip, 0.787 mm/ .031" dia. tungsten carbide ball

Replacement tip, steel involute (normally furnished)

Replacement tip, 0.787 mm/ .031" steel ball

Replacement tip, 1.6 mm/ .062" dia., sapphire ball, 1:1 ratio

Replacement tip, 1.6 mm/ .062" dia., sapphire ball, 2:1 ratio

Replacement tip, 1.6 mm/ .062" dia., sapphire ball, 3:1 ratio

Replacement tip, 1.6 mm/ .062" dia., sapphire ball, 4:1 ratio

Replacement tip, 1.6 mm/ .062" dia., sapphire ball, 5:1 ratio

Replacement adjustable nose mounting bracket

Replacement fixed back plate mounting bracket

Order no.

EAM-1071

CP-116

EAS-1333

EPT-1004

EPT-1007

EPT-1008

EPT-1013

EPT-1059-W1

EPT-1059-W2

EPT-1059-W3

EPT-1059-W4

EPT-1059-W5

EAT-1010

EPL-1140

Lever Type Gage Heads

F

Models and Accessories

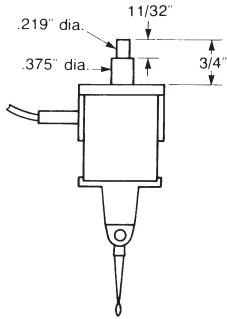

Model EHE-2048 – Post Bracket Back, (BK-108) tamper-proof mounted. Option: Conversion Bracket, EAM-1071, attaches quickly and securely in any rotational direction to suit a wide variety of mounting needs.

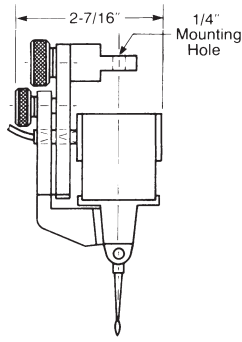

Model EHE-2056 – Adjustable Nose Mount (EAT-1010), tamper-proof mounted. Permits wide choice of positions and approximately 3.8 mm / .150" fine adjustment for quick setup with support close to gaging contact.

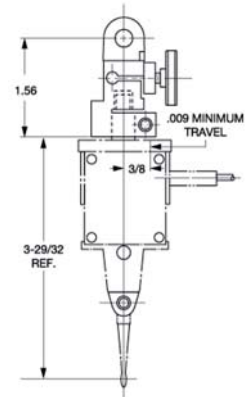

Model EAT-1026 – Fine Adjust Attachment for Lever Type Gage Heads with post mounting option, permits mounting on a wide variety of fixtures.

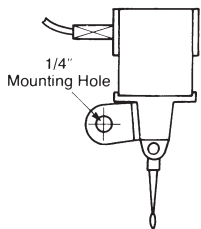

Model EHE-2050 – Fixed Nose Mount (EAM-1045), tamper-proof mounted. Provides support close to gaging contact for the most critical applications.

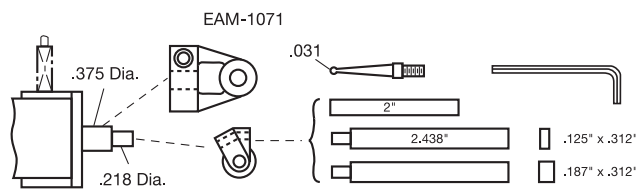

Model EAS-1333 – Mounting Kit for use with EHE-2048. Permits Gage Head to be mounted on a wide variety of stands and holding fixtures. Includes Conversion Bracket, EAM-1071 and 0.787 mm / .031" diameter ball tip contact.

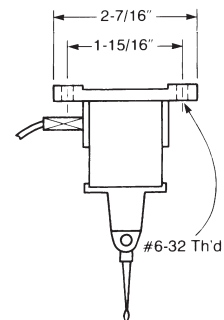

Model EHE-2052 – Fixed Back Plate, (EPL-1140) tamper-proof mounted. For mounting on adjustable plates or slides in fixtures for continuous duty application.

Spring (Pantograph) Type Gage Heads

F



Features

- Friction-free, straight line motion.
- Repeatability better than $0.01 \mu\text{m} / .5 \mu\text{in}$
- Linearity – 0.05% over full range of $\pm 0.250 \text{ mm} / \pm 0.010''$, with repeat accuracy within $0.01 \mu\text{m} / .5 \mu\text{in}$.
- Adjustable pretravel.
- Gaging pressure provided by external spring, from 85 g / 3oz. to 400 g / 14 oz.
- Uses regular 4-48 threaded Contact Points (PT-223 normally furnished).
- Cable length – 2.4 m / 8 ft.

Rugged and reliable, ideal for fixtures or automatic gages

Technical Data

Model EHE-2053

Fixed Back Plate EPL-1140 (15.8 mm / 0.625" wide), tamper-proof mounted. Provides means of attachment for mounting on adjustable plates or slides in fixtures for continuous duty application.

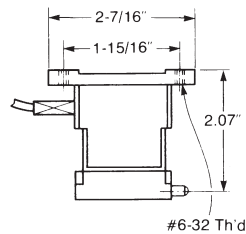

Model EHE-2049

Pressure Spring mount, tamper-proof mounted. Permits setting pre-travel and provides ample gaging pressure regardless of Gage Head position.

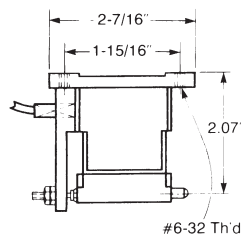

Model EGH-2011

Protective Housing encloses head in tamper-proof mounting. Permits adjustment of both gaging pressure (from 3 to 14 oz.) and pre-travel.

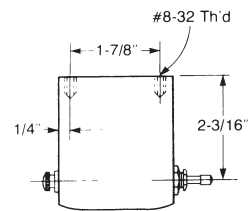

Model EGH-2006

Housing is extended and equipped with heavy duty back plate forming suitable support for use with Model 700 Comparator Stand.

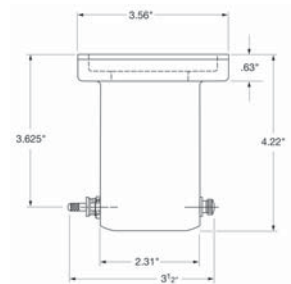

Gage Head Adapter Cables

Order no.

Gage Head Adapter Cables connects Mahr Federal EHE-2XXX and P2XXXF gage heads to Mahr Federal series 432 and 230 amplifiers; 152 mm / 6" long

ECB-1852

Gage Head Adapter Cables connects Mahr Federal EHE 1XXX gage heads to Mahr Federal series 832 and 830 amplifiers; 152 mm / 6"

ECB-1853



Adapters for Cartridge Type Gauge Heads

F

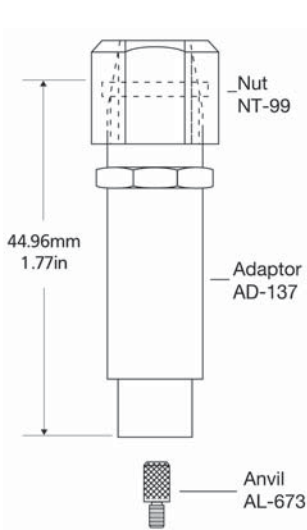

AD-138

Electronic probe adapter permits using cartridge type gauge heads with any regular Mahr Federal indicator.

AT-29

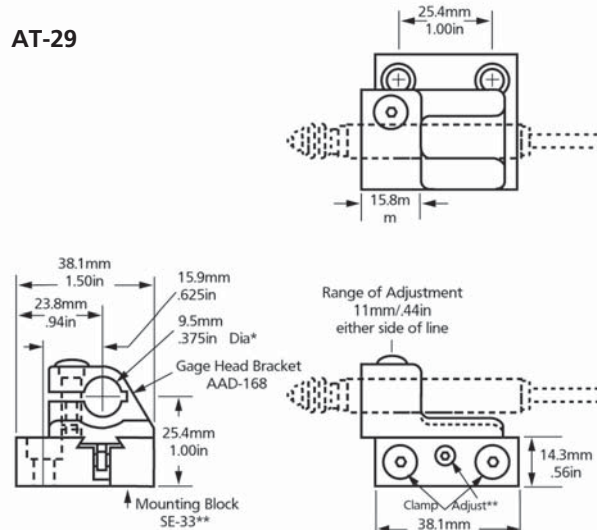

* For .315"/8mm dia. gage heads, bushing BU-197 (not shown) is required.
 ** Gage Head Bracket AAD-168 also fits SE-73 Mounting Block (with adjustment knob in place of socket head adjustment screw)

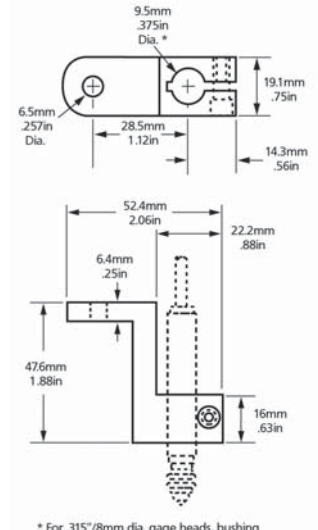

* For .315"/8mm dia. gage heads, bushing EBU-197 (not shown) is required.

AAD-66

"L" bracket used for mounting .375" diameter gauge heads on comparator stands.

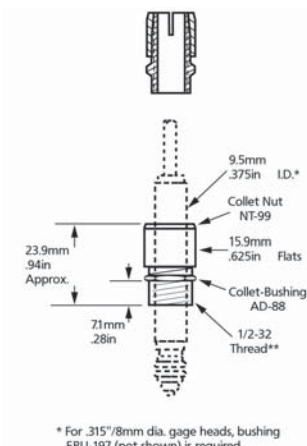

* For .315"/8mm dia. gage heads, bushing EBU-197 (not shown) is required.

AD-87

Split collar adapter for mounting .375" dia. gage heads. For 1/2-32 taps use **V-892**

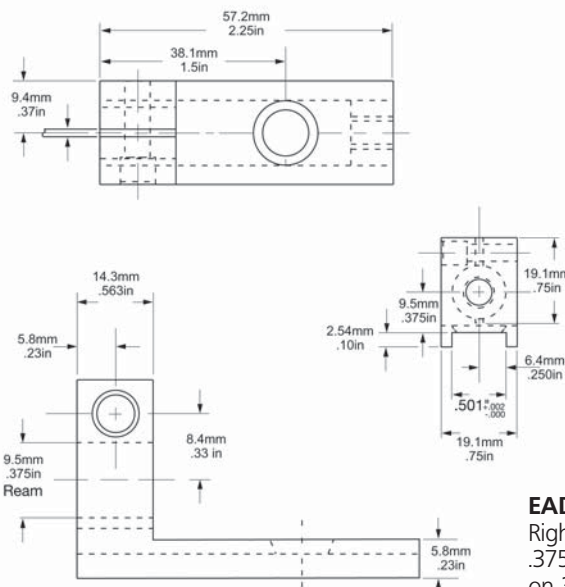

EAD-1029

Right angle adapter for mounting .375" diameter cartridge gage heads on 36B series comparators.

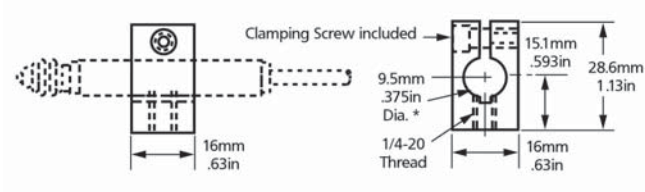

* For .315"/8mm dia. gage heads, bushing EBU-197 (not shown) is required.

AAD-67

For .375" diameter stem, square bracket. 1/4-20 mounting thread.

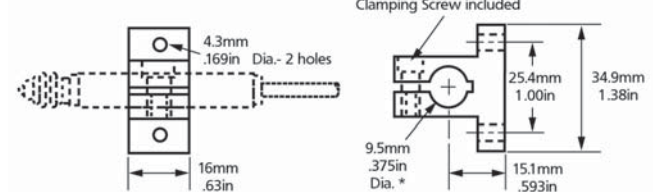

* For .315"/8mm dia. gage heads, bushing EBU-197 (not shown) is required.

AAD-91

"T" bracket flange mounted, two 4.3 mm / .169" through holes. For .375" dia. gage heads.

Inductive Probe Millimar 1340

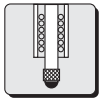

Features

- Unprecedented measuring accuracy and minimum linearity error < 0.01 %, i.e. 0.4 µm over the total measuring range
- Probe is protected against dirt and moisture, thus ideally suited for production related application
- Cable length 1.5 m / 5 ft

Notes:

- Can only be used in conjunction with Millimar 1240

Technical Data

1340

Measuring range	± 2 mm / ± 0.079"
Distance of lower stop ¹⁾	- 2.2 mm / - 0.09" (adjustable)
Distance of upper stop ¹⁾	+ 3.0 mm / + 0.118"
Spindle lift	pneumatic
Measuring force	0.75 N
Sensitivity deviation	0.3 %
Repeatability fw	≤ 0.08 µm
Hysteresis fu	0.08 µm
Linearity deviation	
within range ± 1 mm	0.15 µm
± 2 mm	0.4 µm
Contact points	carbide ball
Protection class acc. to IEC 60529	IP64
Cable output	lateral
Temperature coefficient	0.6 µm/K
Working temperature range	+ 10 ... + 40° C / + 50 ... + 104°F
Operating temperature range	- 10 ... + 80° C / - 14 ... + 176°F
Hysteresis of measuring value	- 10 ... + 80° C / - 14 ... + 176°F

Order no.

5313400

¹⁾ Relative to the electrical zero point

Commercial deviation diagram

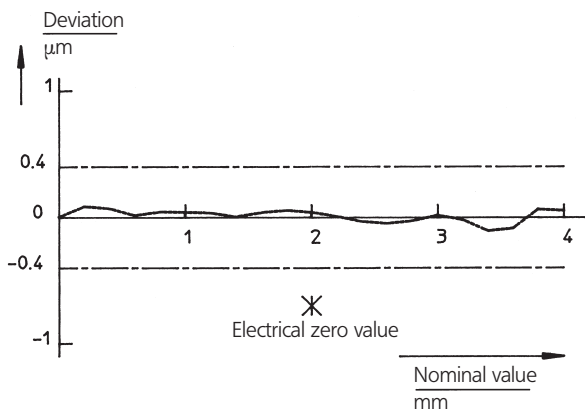

Accessories

	Order no.	Order no.	
Extension Cable 5 m / 16 ft	5313425	Pneumatic Lifter 1340/1	
Extension Cable 10 m / 32 ft	5313421	Pneumatic hand pump with an plug-in hose	
Extension Cable 20 m / 64 ft	5313422	ca. 1 m / 3 ft	5313420
Extension Cable 30 m / 98 ft	5313423	Pneumatic Foot Switch 1340/1F	
		for connecting max. 4 Probes 1340	5313419

Incremental Probe Millimar P1514 / P1526

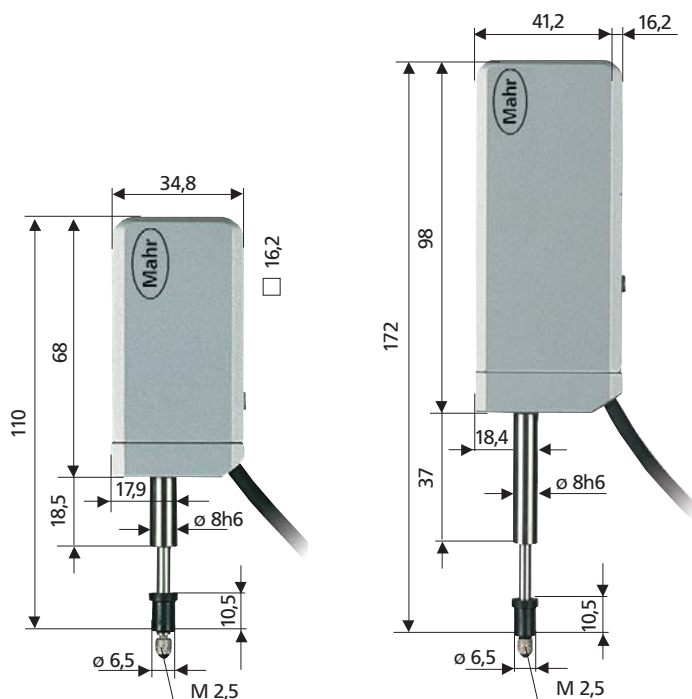

Features

- To obtain the best results use in conjunction with C 1245 I
- Excellent accuracy over a large measuring range
- Supplied with: Finger lifter

Technical Data

Probe type	P1514	P1526
Output signal		1 Vss
Measuring system	DIADUR-glass scale with incremental graduation	
Scale graduation	4 μm	
Signal period	2 μm	
Measuring range	12 mm / 0.47"	25 mm / 0.98"
System accuracy	± 0.2 μm	
Operating position	no limitation	
Measuring force		
Vertical, downwards	0.6 ... 0.85 N	
Vertical, upwards	0.35 ... 0.6 N	
Horizontal	0.48 ... 0.73 N	
Admissible measuring speed	0.5 m/s	
Admissible lateral force	0.8 N	
Max. Acceleration¹⁾		
Shock in m/s ²	1000	
Vibration in m/s ²	100	
Protection class acc. to DIN	IP50	
Reference temperature	20°C / 68°F	
Working temperature	+ 10 ... + 40° C / + 50 ... + 104°F	
Storage temperature	-20 ... 70°C / - 4 ... + 158°F	
Weight excluding cable	100 g	180 g
Connection cable	1.5 m / 5 ft	
Order no.	5315140	5315260





Accessories

	Order-no.
Cable lifter with integral pneumatic damping	3014019
Extension cables	
3 m / 10 ft	4407663
5 m / 16 ft	4407662
7 m / 23 ft	4407661
10 m / 32 ft	4407660

1) The accuracy of this data is not guaranteed

Millimar. Evaluation Instruments

OVERVIEW

	C 1200 IC	830	832	C 1208	C 1216
					
Catalog page	7 - 24	7 - 25	7 - 26	7 - 32	7 - 33
Display	Large analog scale with 2 tolerance markers	Needle analog scale	Analog display with 1 digital line display	Background lit LCD with an analog display and a two line digital display	Background lit LCD with an analog display and a two line digital display
Measuring channels	1 Inductive Probe (A, B)	Acc. to type, up to: • 2 Inductive Probes (A, B)	Acc. to type, up to: • 2 Inductive Probes (A, B) • 1 Pneumatic device (A, B)	Acc. to type, up to: • 2 Inductive Probes (A, B) • 1 Pneumatic device (A, B)	Acc. to type, up to: • 2 Inductive Probes (A, B)
Compatible Inductive Probe (carrier frequency)	Mahr	Mahr Federal	Mahr / TESA / Mahr Federal	Mahr / Mahr Federal	Mahr / Mahr Federal
Max. Resolution	0.1 μm / .000005"	0.1 μm / .000005"	0.01 μm / .000001"	0.1 μm / .000005"	0.01 μm / .000001"
Input Combinations	+A, - A	+A, - A, +B, -B, A + B, A - B, B - A, -A - B	+A, - A, +B, -B, A + B, A - B, B - A, -A - B	+A, - A, +B, -B, A + B, A - B, B - A, -A - B	+A, - A, +B, -B, A + B, A - B, B - A, -A - B
Features / Programs	1	2 / 2	2 / 2	2 / 2	2 / 2
Test steps	1	1	1	1	1
Dynamic measurements	—	—	MAX, MIN, MAX-MIN, (MAX+MIN)/2	MAX, MIN, MAX-MIN, (MAX+MIN)/2, mean	MAX, MIN, MAX-MIN, (MAX+MIN)/2, mean
Statistics functions	—	—	—	—	—
Classification	—	—	—	—	—
Control inputs and outputs / SPS connections	—	—	3 inputs, 5 TTL Opto-coupler outputs	3 Opto-coupler inputs, 3 Opto-coupler outputs	3 Opto-coupler inputs, 3 Opto-coupler outputs
Analog output	—	1	1	—	1
Data interfaces / ports	—	—	RS232, 9 pin, plug	RS232, 9 pin, plug	RS232, 9 pin, plug
Configuration	Turn switch	Turn switch	Keypad	PC, Keypad	PC, Keypad
Battery operated	yes	yes	yes	—	—
Dimensions in mm (H x W x D)	137 x 157 x 80	165 x 190 x 148	254 x 168 x 143	205 x 160 x 165	205 x 160 x 165

C 1245	1240	S 1840	X 1715	X 1741	1901 TA
					
7 - 34	7 - 35	7 - 36	7 - 37	7 - 38	7 - 39
Analog scale with a two line digital display	Evaluation instrument with 2 adjustable tolerance markers	1 illuminated bar and a two line digital display	None Only via PC, supplied with Software D1000X	None Only via PC, supplied with Software D1000X	None Measuring amplifier with analog output
Acc. to type, up to: • 8 Inductive Probes • 4 Incremental Probes • 1 Pneumatic device • 8 Analog Signals or a combination of the above	Acc. to type, up to: • 2 Inductive Probes (A, B)	Acc. to type, up to: • 2 Inductive Probes (A, B) • 1 Pneumatic device	Acc. to type, up to: • 8 Inductive Probes • 4 Incremental Probes Sensors • 1 Pneumatic device • 8 Analog Signals • 2 Temperature Sensors or a combination of the above	Acc. to type, up to: • 16 Inductive Probes • 8 Incremental Probes • 1 Pneumatic device • 8 Analog Signals • 4 Temperature Sensors or a combination of the above	1 Inductive Probe
Mahr / Mahr Federal	Mahr	Mahr / Mahr Federal	Mahr / TESA / Mahr Federal	Mahr / TESA / Mahr Federal	Mahr
0.1 μm / .000005"	0.01 μm / .000001"	0.1 μm / .000002"	0.1 μm / .000002"	0.1 μm / .000002"	—
Formula editor for 80 characters Functions: + / - / * / +/- () / Factor	+A, -A, +B, -B A+B, +A-B, -A+B, -A-B	A, -A, B, -B, A+B, A-B, -A+B, -A-B	Formula editor for 80 characters Functions: + / - / * / +/- () / Factor	Formula editor for 80 characters Functions: + / - / * / +/- () / Factor	—
16 / 6	2 / 2	2 / 2	16 / 6	16 / 6	1
6	1	1	6	6	—
MAX, MIN, MAX-MIN, (MAX+MIN)/2, mean	MAX, MIN, MAX-MIN, (MAX+MIN)/2, mean	MAX, MIN, MAX-MIN, (MAX+MIN)/2, mean	MAX, MIN, MAX-MIN, (MAX+MIN)/2, mean	MAX, MIN, MAX-MIN, (MAX+MIN)/2, mean	—
N, x-quer, S, Xmax, Xmin, Range	n, xn, x, s, R	—	N, x-quer, S, Xmax, Xmin, Range	N, x-quer, S, Xmax, Xmin, Range	—
max. 998, max. 62 auf I/O	max. 30	—	max. 998, max. 5 auf I/O	max. 998, max. 79 auf I/O	—
3 Opto-coupler inputs, 6 Opto-coupler outputs	3 Opto-coupler inputs, 3 TTL outputs	3 Opto-coupler inputs, 3 Opto-coupler outputs	3 Digital inputs, 6 Digital outputs	6 Digital inputs, 12 Digital outputs	—
1	1	1	1	2	1 Output voltage 1 Current output
RS232, 9 pin, plug PC, Keypad	RS232, 9 pin, plug Keypad	RS232, 9 pin, plug PC, Keypad	RS232, 9 pin, plug PC,	RS232, 9 pin, plug PC	—
—	—	—	—	—	—
210 x 160 x 155	195 x 156 x 120	487 x 47 x 144	160 x 205 x 165	235 x 180 x 160	170 x 43 x 100

Millimar 1200 IC Compact amplifier

M



1200 IC

Features

- Compact housing
- Battery powered for portable usage in the workshop
- Large analog display with 2 tolerance markers
- Quick and reliable display of the measured value
- Switchable measuring direction
- One inductive probe can be connected
- Fine adjustment due to the large range zero setter
- Battery operation with the commercially available round R14 batteries
- Test button for batteries
- Supplied with: Mains adapter and operating instructions

Technical Data

	1200 IC	1200 IC/MZ
Measuring range / Resolution	± 3 µm / 0.1 µm ± 10 µm / 0.2 µm ± 30 µm / 1 µm ± 100 µm / 2 µm ± 300 µm / 10 µm	± .0001" / .000002" ± .0003" / .00001" ± .001" / .00002" ± .003" / .0001" ± .01" / .0002"
Scale length		120 mm / 4.724"
Response time		350 ms
Single meas. combinations		+A, -A
Range of zero adjustment: 5 and 100 µm		1 Large range setter
Deviation spread referring to measuring range		≤ 2.5%
Protection class acc. to DIN		IP40
Working temperature range		+ 10... + 40° C / + 50... + 104° F
Power supply		mains adapter, 9V = ~5 VA
Power consumption		ca. 0.1 W
Dimensions		137 x 157 x 80 mm / 5.394" x 6.181" x 3.149"
Weight		1 kg / 2.205 lbs
Order no.	5312000	5312009

Accessories

	Order-no.
Battery , R 14 battery 1.5 V, (6 are required)	3004424

For appropriate Inductive probes please refer to pages 7-6 to 7-15

Millitron 830 Gaging amplifier

F



Features

- Battery operates more than 8 hours under full load
- Choice of Power Modules for 120 or 240 VAC operation
- ± 2 volt analog output
- Conforms to CE Standards
- Dual input - for single or differential modes
- Normal/Reverse transducer setting
- Selectable ranges in either Inch or Metric units.
- Calibration adjustments for each input.
- Convenient, front-mounted controls.
- Tilt base provides stable support and easy adjustment for best viewing angle.
- The essential performer for today's slim budgets
- For appropriate inductive probes please refer to pages 7-6 to 7-18

Technical Data

Repeatability	to within 0.00005 mm / .000002" or 1/10 of a graduation, whichever is greater
Linearity	less than 4/5 of a scale division
Calibration	less than 4/5 of a scale division
Response Speed-Display	less than .5 seconds for 10% to 90% step follow
Response Time - Output	< 15 ms
Dimensions	approx. 165 mm / 6.5" h x 190 mm / 7.5" w x 148 mm / 5.8" d
Temperature at specified accuracy	20°C / 68°F $\pm 2^\circ\text{C}$
Operating temperature	5° to 45°C / 40° to 110°F, with a temperature coefficient of .02% change/°C x full scale range
Storage temperature	0° to 60°C / 32° to 140°F

Model	Order-no.			Ranges	Resolution
	120V	220V EU	240V UK		
Linear:					
Standard Unit				$\pm 100 \mu\text{m}$ / $\pm .004"$	5 μm / 200 μm
830 F	2121421	2121431	2121441	$\pm 20 \mu\text{m}$ / $\pm .001"$	1 μm / 50 μm
830 M	2121404	2121405	2121425	$\pm 10 \mu\text{m}$ / $\pm .0002"$	0.5 μm / 10 μm
High Resolution – Inch				$\pm 200 \mu\text{m}$ / $\pm .004"$	10 μm / 200 μm
830 F	2121424	2121434	2121444	$\pm 50 \mu\text{m}$ / $\pm .001"$	2.5 μm / 50 μm
				$\pm 10 \mu\text{m}$ / $\pm .0001"$	0.5 μm / 5 μm
Angular:	120V	220V EU	240V UK		
Angular unit - ARCSEC (used with Mahr Federal Level Heads)				$\pm 1000 \text{ Sec}$ / $\pm .010"$	50 Sec / 500 μm
830 F	2121422	2121432	2121442	$\pm 200 \text{ Sec}$ / $\pm .002"$	10 Sec / 100 μm
				$\pm 20 \text{ Sec}$ / $\pm .0004"$	1 Sec / 20 μm

Accessories

	Order-no.	Compatible Probes	
		Used on 830 F	Used on 830 M
Analog Output Connector	PRT-2380	P2001 F	P2001 M
120V Battery Charger	EBY-1016	P2004 F	P2004 M
220V Battery Charger (EU)	EBY-1019	P2010 F	P2010 M
240V Battery Charger (UK)	EBY-1020	P2104 F	P2104 M
Battery	EBY-1021	EHE-2XXX	1301, 1303,
Battery Eliminator Kit for 110V Models	EKT-1237-W1	EGH-Levels	1304, 1318
Battery Eliminator Kit for 220 Models	EKT-1237-W2		

Millimar. Electronic Levels

OVERVIEW

Electronic Levels Applications

F

Measuring with a Mahr Federal Electronic Level is a relatively simple procedure. In a typical profile application, for example, measurements are made by moving the sensing heads in convenient increments along a straight path on the surface being checked. Comparative readings are taken at each increment.

Computer assisted models allow economical, fast, and error-free calculations to be made automatically. As prompted by the computer, the operator simply enters the value at each measurement point by pressing a hand-held switch. Depressing a computer key activates automatic analysis. Within moments, the results are displayed and printed, if desired, for permanent record.

Surface Deviation (Machine Tools)

The accuracy of machine tools begins with proper levelness plus the relationship between the ways and the table. These relationships are critical during the manufacturing process.

Once the level is zeroed, the instrument functions as a spirit level, and will check the overall levelness of the machine components to a very high degree of accuracy.

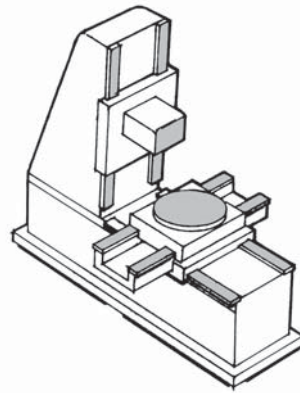

Shown here are just a few of the many surfaces that can be checked on a machine tool using the Electronic Level.

Differential Sensing

To aid in differential profiling applications, two level sensing heads, operating simultaneously with a single amplifier, are used. When the sensing heads are arranged for opposite response to a common motion (such as vibration or a shift in attitude of the object whose surfaces are being compared), they will ignore the common motion and respond only to changes which affect the

two heads differentially. A deviation of flatness, squareness, parallelism or alignment, therefore, can be accurately determined even though the object (such as a surface plate or a machine way) does not maintain constant orientation.

Surface Plate Flatness

The next progression in data collection is to combine and print a number of surface straightness checks onto a single chart. This is useful for checking the surface flatness of machine beds and surface plates.

Although the Moody Method for checking surface plates has been traditionally used to check flatness, the computer assisted digital Electronic Level System is ideally suited for highly precise profiling of surface plates and large machined surfaces while eliminating tedious and time-consuming data recording and calculations required by manual systems.

Determining surface flatness is accomplished by using a straight edge as a guide and moving the level along the edge.

Readings are recorded at convenient locations, and entered into the computer via handswitch to produce the surface profile.

Machine Tool Evaluation

ANSI Standard B5.54, for machining center evaluation, refers to levels as an important part of machine evaluation, calling out angular deviation as a major contributor to machine tool errors.

Electronic Levels are ideal for monitoring such deviations as pitch, yaw and roll.

When used with the Spindle Mount Attachment (EAT-1062), levels become an essential tool towards total Machine Tool Evaluation.

Electronic Levels

F

Offer fast response, fine resolution and excellent repeatability

Features

- Used to determine any deviation in the right angle relationship between a horizontal surface and the earth's gravitational force (usually expressed as an angular or linear deviation from absolute level).
 - Show any change in this relationship over time.
 - Compare the orientation attitude of separate or adjacent horizontal surfaces.
 - Show any change in this comparison over time.
 - Level systems are angular-linear compatible.
 - Sensing heads are interchangeable with Mahr Federal's gage heads to accommodate linear measurements.
 - Fast Response: quick response to slight angular changes permit taking fast and accurate measurements at various sensing head positions or taking dynamic position readings.
 - Resolution/Repeatability: Mahr Federal's Electronic Levels far exceed the sensitivity and accuracy of precision spirit levels with a resolution to 6 μin per foot (.1 arc second), compared to the spirit level's resolution of .0001" per foot. With repeatability at ± 1 arc second, Electronic Levels are ideal for ultra-high resolution profiling.
 - Direct Dimensional Readout: multiplier feature permits operator to view displacement caused by the angular measurement of the level head; this is displayed as an inches per foot readout rather than arc seconds: eliminates readout confusion when switching from spirit levels to electronic levels.
- Angular-Linear Compatible: sensing heads are easily interchangeable with Federal gage heads to accommodate linear measurements.
 - Operator Friendly: Level systems are often compared to the autocollimator or laser calibration systems. In each case, the measurement technique is basically the same. Electronic Levels, however, are much easier to set up and operate. Results are obtained cost-effectively without requiring time consuming sight path alignments. There are no optical surfaces to keep clean, and the Level does not need a turbulence-free environment to achieve accurate readings.



How they work

As shown in the figure, our Sensing Head operates on the pendulum principle, with a pendulum supported by two reed springs attached to an extension block at the top of the Sensing Head housing.

Tilting the head causes a change in the position of the pendulum's shading loop in relation to the center leg of the core. This produces an electrical imbalance in the amount of flux passing through the two secondary coils, delivering a signal proportional to the displacement of the pendulum.

This is displayed on a Mahr Federal amplifier meter which is graduated in seconds of arc.

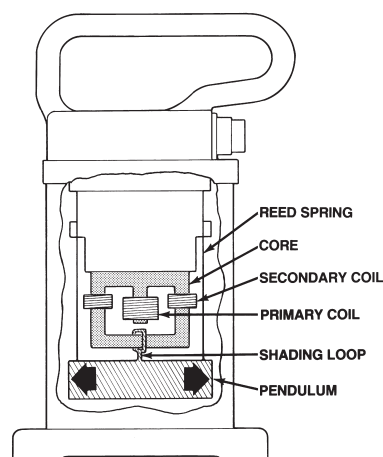

Millitron 832 Digital Electronic Amplifier



Features

- Dynamics – simultaneously computes the minimum, maximum, T.I.R., nominal and actual gage head signal for dynamic measurement capability.
- Multi-Range – three selectable ranges in inch or metric units.
- Message Center – display provides a simple “menu-driven” setup procedure in English, French or Spanish.
- RS-232 Output – for communicating with Data Collection Devices.
- Two Gage Head Input – Independent reading or for providing the capability of “summing” for diameter reading, matching clearances, runout and parallelism.
- Angular units – selectable arc seconds or millirads for angular measurement applications (see Electronic Levels).
- User selectable password for full lockout capability or individual key lockout in both setup and gaging modes.
- Specific models available for use with Mahr, Mahr Federal, Tesa or Marposs inductive probes.

Technical Data

	Measuring Range	Digital Resolution	Analog Minimum Grad.
Linear	±2 mm / ±0.100" ±.200 mm / ±010" ±.020 mm / ±001"	.001 mm / .0001" .0001 mm / .00001" .00002 mm / .000001"	0.1 mm / .005" 0.1 mm / .0005" .001 mm / .00005"
Angular	5 mrad / ±1000 arc sec. 1 mrad / ±200 arc sec.	.005 mrad / 1 arc sec. .0005 mrad / 0.1 arc sec.	.25 mrad / 50 arc sec. .05 mrad / 10 arc sec.
Auto Range	automatically selects the smallest range for the best resolution, in both linear and angular units		
Repeatability	±1 digit		
Calibration Accuracy	±1 digit		
Linear Error	less than .025% of full scale		
Response Time	42 msec.		
Thermal Stability	.01% /C x full scale		
Temperature Range:	20°C / 68°F ±2°C		
At Specified Accuracy	5° to 45°C / 40° to 110°F, with a temperature coefficient of .02% change/°C x full scale range.		
Operating Storage	0° to 60°C / 0° to 140°F		
Digital I/O	five TTL opto-isolated outputs		
Data Output	RS-232, transmits Channels A, B, or both, units, and tolerances		
Analog Output	±5 VDC full scale for displayed value signal		
Measuring Modes	Actual, Minimum, Maximum, T.I.R., Nominal		
Tolerance Indicators	five LEDs		
Weight	3.5 lbs. / 1.58 kg		
Dimensions	168 mm w x 254 mm d x 143 mm h / 6.63" w x 10" d x 5.63" h		
Gage Head Display	A, B or both at any time		
Auto Power Off	User selectable, up to 99 minutes of non-use		
Power Requirements	rechargeable battery, 10 hour operation under full load: or 120 VAC/240 VAC 50-60Hz with power module (furnished with Amplifier)		
Replacement Battery	EBY-1015 Ni-Cad rechargeable, 4.8v, 2.5 amp hours		

Millitron 832 Digital Electronic Amplifier

Technical Data

Power	832 F Mahr Federal probe type Order no.	832 M Mahr probe type Order no.	832 T Tesa probe type Order no.	832 U Marposs probe type Order no.
120VAC adapter	2004005	2004000	2004015	2004020
US battery/120VAC charger	2004007	2004002	2004017	2004022
EU/UK 220/240VAC adapter	2004006	2004001	2004016	2004021
EU battery/220VAC charger	2004008	2004003	2004018	2004023
UK battery/240VAC charger	2004009	2004004	2004019	2004024

Accessories

	Order no.
Storage Cover (opaque)– protection for the 832 Amplifier when used in harsh environments	ECV-1276
Oil/Splash Cover (clear)–protection for the 832 Amplifier when used in harsh environments	ECV-1285
Footswitch for HOLD/RESUME , 3 m / 10 ft cable (15 pin)	ECB-1857
Footswitch for DYNAMIC RESET , or remote zeroing 3 m /10 ft cable (15 pin)	ECB-1858
Footswitch for SEND DATA , 3 m / 10 ft cable (15 pin)	ECB-1859
Footswitch for DYNAMIC RESET , or Remote Zeroing, 1.5m / 5 ft cable (Phone Plug)	300-50
Remote pushbutton for DYNAMIC RESET , or remote zeroing 1.5 m / 5 ft cable (Phone Plug)	ECB-1855
Remote pushbutton for SEND DATA , 1.5 m / 5 ft cable (15 pin)	ECB-1860
Remote pushbutton for HOLD/RESUME and SEND DATA , 3 m / 10 ft cable (15 pin)	ECB-1868
Relay Box – five relays each with Normally Open/Normally Closed contacts; Contact Rating – 30 Vdc/120 Vac, 3 amps Power Supply – 120 Vac Dimensions – 39 mm x 129 mm x 134.6 mm d/1.53" x 5.082 x 5.3" with ECB-1886W-2, 6.1 mm/24" interconnect cable for amplifier to relay box	EKT-1236-W3
Mating connector , Digital I/O connector (15 pin MALE)	ECN-1695-W2
Mating connector , Reset Data connector (3/32 microphone plug)	ECN-1693
Mating connector , RS-232 Digital Output connector (9 pin FEMALE)	ECN-1695-W1
Mating connector , Gage Head to amplifier connector (5 pin MALE)	ECN-1690
Battery Charger Modules (For 832 Units using 3 pin connector)	
Plug-in 120 VAC, 50-60Hz charger for use with 120 Vac battery operated units	EBY-1028
220 VAC, 50-60Hz charger for use with 220 Vac battery operated units	EBY-1029
240 VAC, 50-60Hz (UK) charger for use with 240 Vac battery operated units	EBY-1030
Power Supply Module (Bypass battery operated units to direct AC source operation)	
For 120 Vac models (For 832 Units using 3 pin connector)	2010000
For 220/240 Vac models (For 832 Units using 3 pin connector)	2010001
Printers	
MSP-2 line printer : includes power module for 230 V Euro / 120 V US	4102040
RS-232 Cable : Amplifier to Printer, 3 m / 10 ft	7024634
Paper rolls for MSP-2 Line Printer	4102041

For appropriate inductive probes please refer to pages 7-6 to 7-18

Electronic Levels Ordering Information



Differential Level System

The Differential Level System operates simultaneously with a single amplifier, permitting an immediate comparison between two surfaces.

Adjustable bases permit setup on surfaces that are out-of-level or square by as much as $\pm 1.5^\circ$.

Each system includes:

- 832 F Amplifier with power module and storage case
- 2 EGH-2013-W2 Electronic Level Heads with 6m / 20ft cables
- 2 EAT-1029 Adjustable Bases
- ECB-1871 Remote data enter handswitch with 6m / 20ft cable

Ordering no.

Type

Differential Level System described above with 120 VAC 50/60 Hz power module
Differential Level System described above with 220 VAC 50/60 Hz power module (EU)

Order no.

EMD-832P-48-W1
EMD-832P-48-W2

Automatic Profiling System

Ideally suited for highly precise profiles of surface plate and large machine surfaces, eliminating tedious and time-consuming data recording and calculating required by manual systems.

Each system includes:

- 832 F Amplifier with power module and storage case
- 2 EGH-2013-W2 Electronic Level Heads with 6m/20ft cables
- 2 EAT-1029 Adjustable Bases
- ECB-1871 Remote data enter handswitch with 6m/20ft cable
- ECB-1872 RS-232 0.6 m/4 ft interconnect cable, 9 pin-9 pin
- Notebook computer (EAS-2836) with notebook printer (ERO-1063) and cable (ECB-1775)
- Mahr Federal Profiling Software (EDD-1035) for single line profile measurements and Moody Method surface plate profiling. Includes 3 data outputs (printout of data point readings, numeric and isometric plots of surface plate readings)



Surface Plate Certification Software

- Moody and Profile Analysis
- Isometric or numeric plots
- Automatic grading according to industry standards
- On-line help
- Flexible path sequence and orientation
- Multiple run averaging
- Difference of Data Files

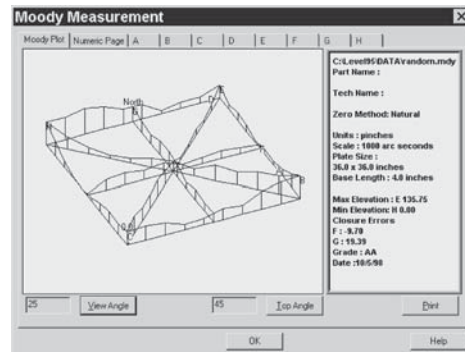

Ordering no.

Type

Automatic Profiling System described above with 120 VAC 50/60 Hz power module
Automatic Profiling System described above with 220 VAC 50/60 Hz power module (EU)
Surface Plate Certification Software

Order no.

EMD-832P-50-W1
EMD-832P-50-W2
EDD-1035

Electronic Levels Ordering Information

Accessories

Type	Order no.
Electronic Level Gage Head , with 2.5m / 8 ft cable, 210 mm / 8.2" x 114 mm / 4.5" x 50.8 mm / 2" 3.5 kg / 7.75 lbs.	EGH-2013-W1
Electronic Level Gage Head , same as above except with 6 m / 20 ft cable	EGH-2013-W2
Adapter Cable , to connect EGH-13 Electronic Level Gage Heads or EHE-1xxx Gage Heads to a Series 832 & 830 Gaging Amplifier, 1.8 m / 6 ft long	ECB-1853



**EAT-1029
(Adjustable Leveling Foot)**

The adjustable level foot mounts to the base of the level head. Typically used to assist in leveling the head to its true zero position.



**EAT-1054
(Magnetic Base)**

Incorporates a magnet to fix it in position, providing stability when mounted on a moving carriage.



**EAT-1055
(Vee Base)**

Has a 120° Vee precision ground into the 102 mm / 4" base for measuring the straightness or alignment of cylindrical surfaces.

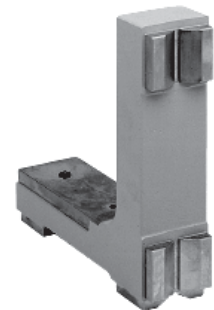

**EAT-1056
(Right Angle Attachment)**

Has two 152 mm / 6" surfaces, accurately ground to 90°, to simplify measuring flatness on horizontal or vertical and cylindrical surfaces. Each adjacent pair of faces is square to within 0.5 μm / 25 μin. Attachment includes 120° Vee face, which is parallel to its base to the same limit.

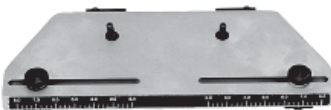

**EAT-1057
(Adjustable Base)**

A three-pad base lets you adjust the distance between the pads from 50mm/2in to 203mm/8 in when using the "Grid" or "Union Jack" measuring methods. Can also be used for straightness movement checks.



**EAT-1062
(Spindle Block)**

A special spindle mounting block to hold the level head in a horizontal or vertical spindle. Utilizes a 19mm/.750 in bar for mounting and allowing checking angular motion on a machine tool per B5.54 Calibration Standard.

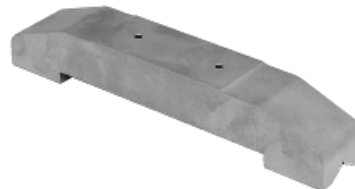

**EAT-1061
(29.5mm/11.625in Base)**

Has a 29.5mm/11.625in ground, flat surface for leveling machine beds and ways. It also has a 120° Vee ground into the base, permitting the base to be positioned on a cylindrical surface. When coupled with an 832 or 830 Electronic Amplifier while in the inch mode, it can display inches/feet as a direct reading.

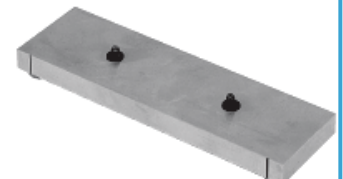

**EAT-1058 (50 mm / 2")
EAT-1059 (102 mm / 4")
EAT-1060 (152 mm / 6")**

A three-pad base which provides the flexibility to maximize data accumulation for surface plate calibration. Available in three pad spacing sizes.

Millimar C 1208 Compact amplifier with background lit display



Features

- Favorites, frequently required functions can be assigned to the SELECT key
- Static measurements $\pm A$, $\pm B$ and all combinations
- Dynamic measurements: Max, Min, Max-Min, Max+Min, mean
- Auto-Detect-Mode, two measuring instruments can be connected (Probe, Plug Gage . . .)
- Programmable via the integrated key pad or by RS232 interface in conjunction with the MS-Windows configuration Software

Display

- Background lit LCD-Display with an analog and a two line digital display
- 5 three color status lamps for warning and tolerances limits
- Up to 2 features can be simultaneously displayed

Connections

- 2 inputs for inductive probes (also compatible with probes from Mahr, Tesa, Mahr-Federal)
- RS232 interface
- 3 digital inputs for measurement start, master measurement, send measured values, . . .
- 3 digital outputs for GO, NO GO, rework, measuring time, . . .
- Supplied with: D1000S Software, operating instructions and a mains power supply plug

Technical Data

Display	Background LCD, 115 mm x 70 mm
Analog scale	Pointer, 61 graduations
Range and text display	7 digit LCD, 5 x 7 dot matrix, alpha-numeric
Measured value display	7 digit LCD, 7 segments
Tolerance display	5 LEDs, 3 colors
Displayed ranges	± 3 , 10, 30, 100, 300, 1000, 3000, 10000 μm ± 0.0001 ; 0.0003; 0.001; 0.003; 0.01; 0.03; 0.1; 0.3 inch; or tolerance related
Meas. range inductive probe	4000 (± 2000) μm , resolution 0.1 μm

Response time

- Meas. value memory	0.010s
- Digital display	0.100s
- Analog display	0.100s
- Outputs	0.020s

Error limit

- 10 x analog display	2.5%
- Digital display	0.3% (min. 0.2 μm)
Temperature coefficient	0.005%/ $^{\circ}\text{C}$
Operating temperature	0 $^{\circ}\text{C}$. . . 45 $^{\circ}\text{C}$ / 32 $^{\circ}\text{F}$. . . 113 $^{\circ}\text{F}$

Interfaces

Computer, printer	RS232, 9 pin. male (PC-compatible assignment)
- Control outputs	3 Opto-coupler-outputs, 2 24V, 100mA
- Control inputs	3 Opto-coupler-inputs, 24V, 10mA
Power supply via Mains power pack	100V . . . 240V, 47Hz . . . 63Hz
Power consumption	10 VA
Protection class	IP54, with conductive dust IP43
Housing dimensions (H x W x D)	ca. 205 mm x 160 mm x 165 mm ca. 8.07" x 6.29" x 6.49"
Weight	ca. 2.1 kg / 4.6 lbs

Order no.

	Order-no.
C 1208 M Mahr compatible	5312080
C 1208 F Mahr-Federal compatible	5312082
C 1216 M Mahr compatible	5312160
C 1216 F Mahr-Federal compatible	5312162

For appropriate Inductive probes please refer to pages 7-6 to 7-18

Accessories

	Order-no.
Extension cable (9 pin D-Sub-jack to a D-Sub-socket), length 3 m / 10 ft	7024634
Control Unit with 3 push buttons	5318430
Foot switch for	
for Input 1	5330955
for Input 2	5330956
for Input 3	5330957
Adapter non wired for I/O port	7032401
Keypad dust cover	3025712

Millimar C 1216 Compact amplifier with background lit display



Features

- Favorites, frequently required functions can be assigned to the SELECT key
- Static measurements $\pm A$, $\pm B$ and all combinations
- Dynamic measurements: Max, Min, Max-Min, Max+Min, mean
- Auto-Detect-Mode, two measuring instruments can be connected (Probe, Plug Gage . . .)
- Programmable via the integrated key pad or by RS232 interface in conjunction with the MS-Windows configuration Software

Display

- Background lit LCD-Display with an analog and a two line digital display
- 5 three color status lamps for warning and tolerances limits
- Up to 2 features can be simultaneously displayed
- Additional resolution 0.01 μm / 1 μin at measuring ranges from

Connections

- 2 inputs for inductive probes (also compatible with probes from Mahr, Tesa, Mahr-Federal)
- RS232 interface
- 3 digital inputs for measurement start, master measurement, send measured values, . . .
- 3 digital outputs for GO, NO GO, rework, measuring time, . . .
- Analog output
- Programable analog output voltage (max. $\pm 5\text{V}$)
- Supplied with: D1000S Software, operating instructions and a mains power supply plug

Technical Data

Display	Background LCD, 115 mm x 70 mm	Error limit	
Analog scale	Pointer, 61 graduations	- 10 x analog display	2.5%
Range and text display	7 digit LCD, 5 x 7 dot matrix, alpha-numeric	- Digital display	0.3% (min. 0.2 μm)
Measured value display	7 digit LCD, 7 segments	Temperature coefficient	0.005%/ $^{\circ}\text{C}$
Tolerance display	5 LEDs, 3 colors	Operating temperature	0 $^{\circ}\text{C}$. . . 45 $^{\circ}\text{C}$ / 32 $^{\circ}\text{F}$. . . 113 $^{\circ}\text{F}$
Displayed ranges	± 3 , 10, 30, 100, 300, 1000, 3000, 10000 μm ± 0.0001 ; 0.0003; 0.001; 0.003; 0.01; 0.03; 0.1; 0.3 inch; or tolerance related	Interfaces	
Meas. range inductive probe	4000 (± 2000) μm , resolution 0.1 μm 400 (± 200) μm , resolution 0.01 μm	Computer, printer	RS232, 9 pin. male (PC-compatible assignment)
Response time		- Control outputs	3 Opto-coupler-outputs, 2 24V, 100mA
- Meas. value memory	0.010s	- Control inputs	3 Opto-coupler-inputs, 24V, 10mA
- Digital display	0.100s	Power supply via	
- Analog display	0.100s	Mains power pack	100V . . . 240V, 47Hz . . . 63Hz
- Outputs	0.020s	Power consumption	10 VA
		Protection class	IP54, with conductive dust IP43
		Housing dimensions (H x W x D)	ca. 205 mm x 160 mm x 165 mm ca. 8.07" x 6.29" x 6.49"
		Weight	ca. 2.1 kg / 4.6 lbs

Order no.

		Order-no.
C 1208 M	Mahr compatible	5312080
C 1208 F	Mahr-Federal compatible	5312082
C 1216 M	Mahr compatible	5312160
C 1216 F	Mahr-Federal compatible	5312162

For appropriate Inductive probes please refer to pages 7-6 to 7-18

Accessories

	Order-no.
Extension cable (9 pin D-Sub-jack to a D-Sub-socket), length 3 m / 10 ft	7024634
Control Unit with 3 push buttons	5318430
Foot switch for	
for Input 1	5330955
for Input 2	5330956
for Input 3	5330957
Adapter non wired for I/O port	7032401
Keypad dust cover	3025712

Millimar C 1245 Compact amplifier



Features

Functions

- 16 characteristics can be defined
- With the formula editor (80 characters) the input channels C1 to C8 are mathematically linked with 4 basic arithmetical functions with factors and brackets
- Static measurements: current value, square root, arc tangent
- Dynamic measurements: Max, Min, Max-Min, Max+Min, mean,
- Statistical functions: n, x-bar, S, Xmax, Xmin, R
- Programmable via the integrated keypad or with MS-Windows configuration software via the RS232 interface
- Memory can store up to 500 measurements
- Measurement Start / Stop

Display

- Analog indicator instrument for display of measurement values

- Two-line LCD for measuring values and help texts
- 5 three color status lamps for warning and tolerance limits
- Up to 3 features can be simultaneously displayed

Connections

- 2 input modules can be inserted into base unit
- Following modules are available:
 - 4 inputs for Inductive Probes (Mahr, Mahr-Federal, Tesa compatibility)
 - 2 inputs for Incremental Probes
- RS232 interface
- 1 Analog output
- 3 digital inputs for measurement start, master measurement / zeroize, send data
- 6 digital outputs for GO, NO GO, rework, ALL GO, measuring time, 4 classes
- Supplied with: D1000X Software, operating instructions and a mains power supply plug

Technical Data

Display	analog indicator instrument. LCD 53 mm x 40 mm (2.087" x 1.585")
Analog scale	145 mm x 80 mm (5.709" x 3.149")
Range and Text display	7-point LCD, 5 x 7 dot matrix. alphanumeric
Measured value display	7-point LCD. 7 Segment
Tolerance display	5 LEDs, 3-colors
Display ranges	±10, 30, 100, 300, 1000, 3000, 10000 µm ±0.0003; 0.001; 0.003; 0.01; 0.03; 0.1; „3 inch
Measuring range inductive probe	4000 (±2000) µm, resolution 0.1 µm (measured value display)

Response time

- Meas. value memory	0.005s
- Digital display	0.300s
- Analog display	0.050s - 0.300s
- Outputs	0.020s

Error limits

- 10 x Analog display	2 %
- Digital display	0.3 % (min. 0.2 µm)
Temperature coefficient	± 0.005%/°C
Oper. temperature range	0°... 50°C

Interfaces

Computer, printer	RS232, 9 pin. male (PC-compatible layout)
- Control outputs	6 Optocoupler-outputs, 24V, 100mA
- Control inputs	3 Optocoupler-inputs, 24V, 10mA
Analog output. voltage	programmable
Power supply	90 V... 264 V, 47Hz... 63Hz
Power consumption	11 VA
Protection class	IP53 with conductive dust IP43

Housing dimensions (H x B x T)

ca. 210 mm x 160 mm x 155 mm
ca. (8.268" x 6.299" x 6.1032")

Weight

ca. 2 kg / 4.40 lbs

Order no.

	Order no.
C 1245 M Mahr compatible for 4 inductive probes	5331250
C 1245 M Mahr compatible for 8 inductive probes	9037843
C 1245 T Tesa compatible for 4 inductive probes	5331251
C 1245 F Mahr-Federal compatible for 4 inductive probes	5331253
For appropriate Inductive probes please refer to pages 7-6 to 7-18	
C 1245 I for probes P1514, P1526	5331254

Accessories

	Order-no.
Extension cable (9 pin D-Sub-jack to a D-Sub-socket), length 3 m / 10 ft	7024634
Control Unit with 3 push buttons	5318430
Foot switch for Millimar for Input 1	5330955
	for Input 2
	5330956
Adapter non wired for I/O port	7032401
Keypad dust cover	3025712

Millimar 1240 Compact amplifier



Features

- Highly accurate processing of measured values
- Zero setting is possible at any point within the measuring range
- Actual value of a standard can be acquired at the touch of a button
- Statistical functions \bar{x} , s , r and n for 1 parameter
- Tolerance monitoring (with adjustable hysteresis)
- Tolerance field can be set along the total width
- Universal classification possibilities
- Extreme value memories of long stability
- 2 inputs for Mahr compatible inductive probes for single, sum or difference measurements
- Use the RS232C interface to connect a printer / computer / data logger
- Connect a recorder with analog output
- Use the RS232C interface to remotely control all functions
- Supplied with: Operating instructions and a mains power supply plug

Technical Data

Display	analog/digital
Analog display: Measuring range/resolution	
	$\pm 1 \mu\text{m}/0.02 \mu\text{m}$ ($\pm .003 \text{ in}/.0001 \text{ in}$)
	$\pm 3 \mu\text{m}/0.1 \mu\text{m}$ ($\pm .01 \text{ in}/.0002 \text{ in}$)
	$\pm 10 \mu\text{m}/0.2 \mu\text{m}$ ($\pm .03 \text{ in}/.01 \text{ in}$)
	$\pm 30 \mu\text{m}/1 \mu\text{m}$ ($\pm .1 \text{ in}/.002 \text{ in}$)
	$\pm 100 \mu\text{m}/2 \mu\text{m}$ ($\pm .3 \text{ in}/.01 \text{ in}$)
	$\pm 300 \mu\text{m}/10 \mu\text{m}$ ($\pm .00003 \text{ in}/.000001 \text{ in}$)
	$\pm 1000 \mu\text{m}/20 \mu\text{m}$ ($\pm .0001 \text{ in}/.000002 \text{ in}$)
	$\pm 3000 \mu\text{m}/100 \mu\text{m}$ ($\pm .0003 \text{ in}/.00001 \text{ in}$)
	$\pm 10000 \mu\text{m}/200 \mu\text{m}$ ($\pm .001 \text{ in}/.00002 \text{ in}$)
Digital display: Measuring range/resolution	
	$\pm 200 \mu\text{m}/0.01 \mu\text{m}$ ($\pm .08 \text{ in}/.000001 \text{ in}$)
	$\pm 2000 \mu\text{m}/0.1 \mu\text{m}$ ($\pm .008 \text{ in}/.000001 \text{ in}$)
Single meas./ combinations	+A, -A, +B, -B, A+B, +A-B, -A+B, -A-B
Dynamic Functions	Max, Min, Max-Min, (Max+Min)/2, mean
Static Functions	n , x_n , \bar{x} , s , R
Zero adjuster	Zero setting at any point

Deviation spread referring to measuring range

Analog display	$\leq 1.5 \%$
Digital display	$\leq 0.01\%$
Analog output	$\leq 1 \%$
Output voltage	$\pm 5 \text{ V}$
Data output	RS 232 C
Limit switches	2
Signal lamps	3
Response time	15 ms
Control outputs	3
Type of output	TTL
Control inputs	3
Protection class acc. to DIN	IP40
Working temperature range	+10 ... +40°C / + 50. ... + 104° F
Power supply	230 V~/115 V~ $\pm 10\%$, 50–60 Hz (switchable)
Power consumption	ca. 30 VA
Dimensions (W x H x D)	156 x 195 x 120 mm (6.142" x 7.677" x 4.7242)
Weight	2.3 kg / 5.07 lbs

Order no.

Version		Order no.
1240	Front Panel German	5312400
1240	Front Panel English	5312401

For appropriate Inductive probes please refer to pages 7-6 to 7-18 Recommended **Probe 1340** see page 7-16

Accessories

	Order no.
Push buttons 1240/3D for activating 3 different functions e.g., Start, zero setting etc., connection cable 1.5 m/ 5ft	5312430
Foot Switch 1240/1F , connection cable length 2 m/ 5ft	5312431
Control Unit 1240/SG with 3 push buttons and 5 relay outputs	5312439
Classifying Instrument 1240/KG with 20 opto-coupler outputs	5312438
Data Cable to any. PC (9 pin D-jack)/MSP2	7024634
Statistics Printer MSP2 , 230V / 110V	4102040

Millimar S 1840 Compact column amplifier



Features

- Easy to read 3 color analog display
- Measurement in conjunction with inductive probes (e. g. Mahr P2004) or electronic plug gages etc
- Two inputs for inductive probes (compatible with probes from Mahr, Mahr-Federal, Tesa)
- Extensive calculation of input signals: $\pm A$, $\pm B$ and all combinations
- Dynamic measurements: Max, Min, Max-Min, Max+Min, Mean
- Programmable either via the integrated keypad or the RS232 interface by means of MS-Windows configuration software
- Programmable warning and tolerance limits, exceeding the limit causes the color to change from green to yellow to red
- Background lit 2 lined LCD to display measured values, help text and measuring units
- Analog output
- 3 digital inputs (e.g. start of measurement, master measurement)
- 3 digital outputs for GO – NO GO – rework, measuring time
- Supplied with: D1000S Software, operating instructions and a mains power supply plug

Technical Data

Analog display	101 LED elements, 3 colors
Range and Text display	7 point LCD, 14 Segment, alphanumeric
Measured value display	7 point LCD, 7 Segments
Tolerance display	via color changes in the analog display
Display ranges	$\pm 10; 30; 100; 300; 1000; 3000;$ $10000 \mu\text{m}$ $\pm .0003; .001; .003; .01; .03; .1; .3$ inch or tolerance related
Measuring range of inductive probe	4000 (+/- 2000) μm , resolution 0.1 μm (Digital display)
Resolution	0.1 μm / .000005"

Response time

- Meas. value memory	0.008 s
- Analog display	0.020 s
- Outputs	0.020 s

Error limits

- 10 x Analog display	1% (101 LEDs)
- Digital display	0.3% (min. 0.2 μm)
Temperature coefficient	$\pm 0.005\%$ / °C
Operating temp. range	0 ... 45 °C / 32°F ... 113°F

Interfaces

Computer, printer	RS232, 9 pin. male (PC-compatible layout)
- Control outputs	3 Optocoupler Outputs, 24 V, 100 mA
- Control inputs	3 Optocoupler Inputs, 24 V, 10 mA
Analog output	Voltage 1V/mm
Power supply	90 ... 264 V, 47 ... 63 Hz
Power consumption	20 VA
Protection class	IP53
Dimensions (H x W x D)	IP43 with conductive dust ca. 487 x 47 x 144 mm (19.173" x 1.850" x 5.669")
Weight	ca. 1.6 kg / 3.53 lbs

Order no.

	Order no.
S 1840 M Mahr compatible	5330001
S 1840 F Mahr-Federal compatible	5330107

For appropriate Inductive probes please refer to pages 7-6 to 7-18

Accessories

	Order no.
Base Plate , for up to 3 columns	5330901
Wall Mounting	5330902
Connection Cable (9 pin D-Sub-jack to D-Sub-jack), length 3 m / 10 ft	7024634
Control Unit with 3 push buttons	5318430
Foot Switch for Millimar	Input 1 5330955
	Input 2 5330956
	Input 3 5330957
Adapter non wired for I/O port	7032401

Millimar X 1715 Intelligent measurement interface system



Features

Millimar X 1715 is a smart and universal measurement interface system for complex measuring tasks on the production floor. It is ideal as a signal transformer between sensors and the electronic measured data processing.

Functions

- Static and dynamic measurements
- Equation editor
- Definition of 16 features are possible
- One or two point master measurement

Connections

- 1 to 8 measuring device inputs
- RS-232 interface
- Analog output
- 3 digital inputs and 6 digital outputs
- Supplied with: D1000X Software, operating instructions and a mains power supply plug

Technical Data

Measuring range inductive probe	4000 (+/- 2000) μm , Resolution 0,1 μm	Analog output voltage	programmable
Response time		Power supply	90 V ... 264 V, 47Hz ... 63Hz
- Meas. value memory	0.005s	Power consumption	11 VA
- Outputs	0.020s	Protection class	IP53 IP43 with conductive dust
Error limits		Dimensions (H x B x T)	ca. 160 mm x 205 mm x 165 mm
- 0.3% (min. 0.2 μm)		Weight	ca. 2 kg / 4.40 lbs
Temperature coefficient	$\pm 0,005\%/^{\circ}\text{C}$		
Oper. temperature range	0° ... 50°C		
Interfaces			
Computer, printer	RS232, 9 pin. male (PC-compatible layout)		
- Control outputs	6 Optocoupler-outputs, 24V, 100mA		
- Control inputs	3 Optocoupler-inputs, 24V, 10mA		

Order no.

		Order no.
X 1715	Mahr compatible for 2 Inductive probes	9044505
X 1715	Mahr compatible for 4 Inductive probes	9040079
X 1715	Mahr compatible for 8 Inductive probes	9037836
X 1715	Tesa compatible for 8 Inductive probes	9037837

For appropriate Inductive probes please refer to pages 7-6 to 7-18

Accessories

	Order no.
Connection Cable (9 pin D-Sub-jack to D-Sub-jack), length 3 m / 10 ft	7024634
Control Unit with 3 push buttons	5318430
Foot Switch for Millimar	5330955
Input 1	5330956
Input 2	5330957
Input 3	7032401
Adapter non wired for I/O port	

Millimar X 1741 Intelligent measurement interface system



Features

Record measured values and calculate directly into the interface at the earliest possible moment, this is easy with the **Millimar X 1741**. Transfer only a few calculated features, thus increasing the reliability of your automated application.

Functions

- Static and dynamic measurements
- Equation editor
- Definition of 16 features are possible
- One or two point master measurement

Connections

- 1 to 16 measuring device inputs
- RS-232 interface
- 2 analog outputs
- 6 digital inputs and 12 digital outputs
- Supplied with: D1000X Software, operating instructions and a mains power supply plug

Technical Data

Measuring range inductive probe 4000 (+/- 2000) µm,
Resolution 0.1 µm

Response time

- Meas. value memory 0.005s
- Outputs 0.020s

Error limits

- 0.3% (min. 0.2 µm)

Temperature coefficient ± 0.005%/°C
Oper. temperature range 0°... 50°C

Interfaces

- Computer, printer RS232, 9 pin. male (PC-compatible layout)
- Control outputs 12 Optocoupler-outputs, 24V, 100mA
- Control inputs 6 Optocoupler-inputs, 24V, 10mA

Analog output voltage

programmable (2 outputs)

Power supply

90 V... 264 V, 47Hz... 63Hz

Power consumption

11 VA

Protection class

IP53
IP43 with conductive dust

Dimensions (H x W x D)

ca. 235 mm x 180 mm x 160 mm

Weight

ca. 2 kg / 4.40 lbs

Order no.

		Order no.
X 1741	Mahr compatible for 2 Inductive probes	9037840
X 1741	Mahr compatible for 4 Inductive probes	9038383
X 1741	Mahr compatible for 12 Inductive probes	9037814
X 1741	Mahr compatible for 16 Inductive probes	9037813

For appropriate Inductive probes please refer to pages 7-6 to 7-18

Accessories

	Order no.
Connection Cable (9 pin D-Sub-jack to D-Sub-jack), length 3 m / 10 ft	7024634
Control Unit with 3 push buttons	5318430
Foot Switch for Millimar	5330955
Input 1	5330956
Input 2	5330957
Input 3	7032401
Adapter non wired for I/O port	

Millimar Measuring Amplifier 1901 TA with analog output



Features

- The measuring amplifier 1901 TA is to be used in connection with an inductive probe for measurement control processes
- Provides the inductive probe with an AC voltage and converts the carrier frequency signal into output voltage
- Output voltage: ± 10 V (Option: ± 5 V / 0 V to 10 V) at the end of the measuring range
- Simultaneously the output signal current of ± 5 mA at the end of the measuring range is available
- Supply voltage 24 V=
- The housing of the 1901 TA is designed for use in the machine room
- Connections : 1 output for one Mahr compatible inductive probe
- Supplied with: 3 pin socket plug for analog output, 3 pin coupling bushing for power supply and operating instructions

Technical Data

Measuring ranges (adjustable through bridges)	$\pm 125 \mu\text{m}$	Connections	Input	5 pin socket
	$\pm 250 \mu\text{m}$		Output	3 pin socket
	$\pm 500 \mu\text{m}$		Supply	3- pin plug
	$\pm 1000 \mu\text{m}$		Response time	5-10 ms
	$\pm 2000 \mu\text{m}$		Cut-off frequency	90 Hz
Output voltage at end of measuring range	± 10 V	Protection class	IP 54	
Option:	± 5 V / 0 - 5 V / 0 - 10 V	Dimensions: (L x D x H)	43 x 100 x 170 mm	
Current output at end of measuring range	± 5 mA			
Linearity	$\pm 0,3\%$			
Supply voltage	24 V =			

Order no.

		Order no.
1901 TA	Mahr compatible for 1 Inductive probe	5319011
1901 TA/So	Mahr compatible for 1 Inductive probe 0- 10 V	9023856

For appropriate Inductive probes please refer to pages 7-6 to 7-18

Millimar. Air Gaging

APPLICATIONS

Air Gages

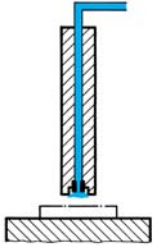

Thickness or wall thickness measurement with Millimar jet air probe.

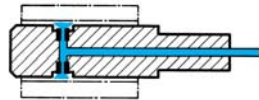

Diameter measurement of cylindrical through bores with Millimar jet air plug gage.

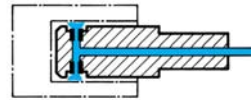

Diameter measurement of cylindrical blind bores with Millimar jet air plug gage.

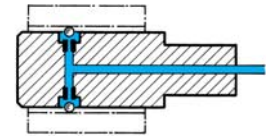

Diameter measurement of cylindrical through bores with Millimar ball contact air plug gage.

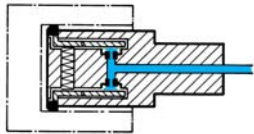

Diameter measurement of cylindrical blind bores with Millimar lever contact plug gage.

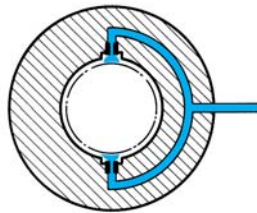

Diameter or thickness measurement with adjustable Millimar jet air caliper gage.

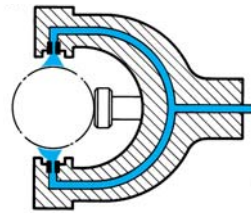

Diameter measurement of cylindrical shafts with Millimar jet air ring gage.

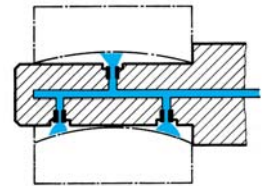

Straightness measurement of a cylindrical bore with Millimar special jet air plug gage.

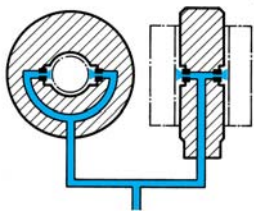

Mating measurement between bore and shaft with Millimar jet air plug gage and jet air ring gage.

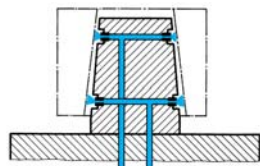

Conicity measurement of an inner cone with Millimar taper jet air plug gage. Measurement based on differential measurement method.

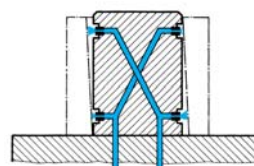

Measurement of perpendicularity of a cylindrical bore to the end face with Millimar special jet air plug gage. Measurement based on differential measurement method.

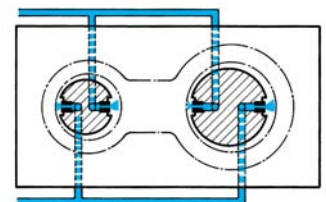

Measurement of spacing between separate cylindrical bores with Millimar jet air plug gages. Measurement based on differential measurement method.

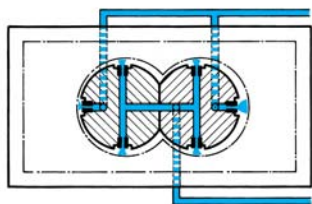

Measurement of spacing between complete cylindrical bores with Millimar jet air plug gages. Measurement based on differential measurement method.

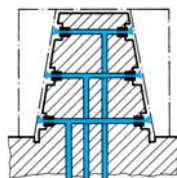

Conicity measurement, form measurement and diameter measurement of inner cone with Millimar taper jet air plug gage.

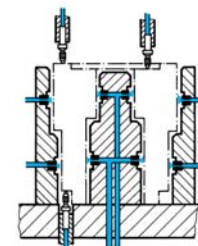

Multiple internal and external measurements with measuring jets and Millimar contact gages in conjunction with a Millimar column gage.

Air Gages



General Technical Data of Air Gages

Air gaging is a measuring system that uses airflow and / or air pressure to determine the size of measured part. The relationship between air pressure and distance of a restriction (workpiece) to the air escape (jets) can be plotted on a graph (line a).

As the distance between jets and work surface increases, the pressure decreases and the ratio becomes linear as represented by the straight section "B". This straight portion of the curve can be accurately calibrated, and represents the scale of the Dimensionair. Compare its length with "C" on the other curve, which is the usable portion of other air gage scales. This longer linear scale gives the Dimensionair its longer usable measuring range.

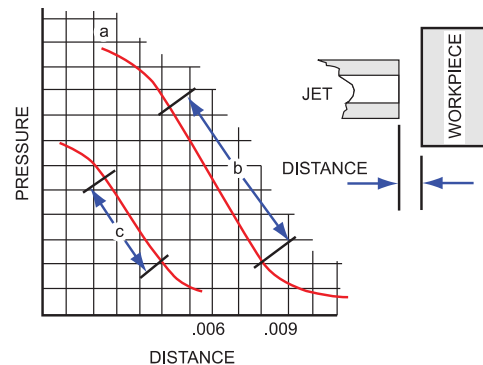

Description

- Air plug gages are used for testing cylindrical through bores or blind bores. The plug gage bodies are equipped with two opposing measuring jets which record the measured value without contact. This arrangement allows the diameter, the diametric roundness and the cylindricity of bores to be calculated using a single jet air plug gage.
- The diameter is measured immediately after the air plug gage is introduced, while the diametric roundness deviation can be tested by rotation around 180° and the cylindricity by movement in a longitudinal direction.
- The maximum measuring range of the air plug gages is 76 μm / .003".
- Air plug gages are furnished in high chrome stainless steel or chrome plated versions and, if required, with a shut-off valve to conserve air consumption.
- The air tooling long service life is due in part to hardened measuring jets which are recessed relative to the generated surface of the measuring body and are, therefore, protected against damage.
- The standard Mahr Federal air tooling is compatible with the complete line of evaluation units. These include Dimensionair, μ Dimensionair, 830 PE, 1840 PE, and 1841 PE signal sharing column. Air/Electric converters for interfacing to gaging computer systems are also available.
- Special air gage designs for measuring taper, straightness and other applications are available. Contact Mahr Federal.

Dimensionair® Air Gages (single master system)



Features

- Uses regular shop air (40 - 150 psig).
- Internal pressure regulator keeps measuring pressures within calibrated range.
- Adjust meter to zero using a single setting master and the zero setting screw.
- High visibility meter has fine line graduations and a needle-thin hand for clear, precise readings. An air filter is included to remove dust and dirt contaminants from air line.
- Tooling mounts to the front of the unit. Connections are tight with finger pressure.
- No recalibration necessary when changing tooling. Just set zero and measure!
- Models available in 5 magnifications, 2 dial styles, and either Metric or Inch.

Technical Data

Magnification	Tooling ID no.	Range	Minimum Graduation	Dial Style	Surface Finish (recommended) µin / um Ra	Part Tolerance (recommended)	Order no.
1250:1	100	.006"	.0001"	Regular 82.6 mm / 3.25" diameter	100 / 2.54	± .002"	2095183
2500:1	50	.003"	.00005"		50 / 1.27	± .001"	2095184*
5000:1	20	.0015"	.00002"		20 / 0.50	± .0005"	2095185*
10000:1	10	.0006"	.00001"		10 / 0.25	± .0002"	2095186
20000:1	5	.0003"	.000005"		5 / 0.12	± .0001"	2095189
1250:1M	100	152 µm	2 µm	Large 152.4 mm / 6" diameter	100 / 2.54	± 50 µm	2095190
2500:1M	50	76 µm	1 µm		50 / 1.27	± 25 µm	2095191*
5000:1M	20	38 µm	0.5 µm		20 / 0.50	± 13.5 µm	2095192*
10000:1M	10	15.2 µm	0.2 µm		10 / 0.25	± 5 µm	2095193
20000:1M	5	7.6 µm	0.1 µm		5 / 0.12	± 2.5 µm	2095194
4000:1	50	.003"	.000025"	Large 152.4 mm / 6" diameter	50 / 1.27	± .001"	2095195*
8000:1	20	.0015"	.000010"		20 / 0.50	± .0005"	2095196*
16000:1	10	.0006"	.000010"		10 / 0.25	± .0002"	2095197
32000:1	5	.0003"	.000005"		5 / 0.12	± .0001"	2095198
4000:1M	50	76 µm	0.5 µm		50 / 1.27	± 25 µm	2095199*
8000:1M	20	38 µm	0.2 µm	20 / 0.50	± 13.5 µm	2095200*	
16000:1M	10	15.2 µm	0.2 µm	10 / 0.25	± 5 µm	2095201	
32000:1M	5	7.6 µm	0.1 µm	5 / 0.12	± 2.5 µm	2095202	

* Contingent upon Plug having equivalent range, see chart on pages 7-45 & 7-46.

Dimensionair® Air Gages (single or dual master system)



Interchangeable Dials

Each Universal Dimensionair is furnished with an adaptor (for connecting standard Mahr Federal air tooling) Optional adaptors are available for virtually any air tooling application.

Features

- Uses regular shop air (40 -150 psig).
- Internal pressure regulators and differential meter assure ultimate stability over full operating range.
- Adjust span and zero setting to tune the gaging range to the interchangeable dial ranges.
- Interchangeable dials provide an easy, inexpensive means to accommodate various ranges
- High visibility meter has fine line graduations and a needle thin hand for clear, precise readings.
- An air filter is included to remove dust and dirt contaminants from airline.
- Tooling mounts to the front of the unit. Adaptors are available for virtually any tooling configuration.

Technical Data

Dial Size diameter mm / *inch* 82.6 / **3.25"**
 Housing Dimensions mm 127 x 187 x 197 (high)
inch 5" x 7.125" x 7.75"
 Weight (including filter) approx. 6.7 kg / 14.25 lbs.
 Operating Pressure 414-1034 kPa / 60-150 psig
 A plastic protective cover for Universal Dimensionair is available
Order No. ACV-1

Ordering Information

Universal Dimensionair, complete with air filter and tooling adaptor for standard Mahr Federal single master air tooling. Supplied with one **2242662** Dial. **Order No. 2098125**

Optional Dials

	Total Range	Range	Dial Graduations	Magnification	Order No.
(inch)	.006"	± .003"	.0001"	1260:1	2242760
	.004"	± .002"	.0001"	1875:1	2242761
	.003"	± .0015"	.00005"	2500:1	2242662
	.002"	± .001"	.00005"	3750:1	2242763
	.0015"	± .00076"	.00002"	5000:1	2242764
	.001"	± .0005"	.00002"	7500:1	2242765
	.0006"	± .0003	.00001"	10000:1	2242766
(metric)	152 µm	± 76 µm	2 µm	1260:1	2242770
	100 µm	± 50 µm	2 µm	1875:1	2242771
	76 µm	± 38 µm	1 µm	2500:1	2242772
	50 µm	± 25 µm	1 µm	3750:1	2242773
	38 µm	± 19 µm	0.5 µm	5000:1	2242774
	15.2 µm	± 7.6 µm	0.2 µm	10000:1	2242776

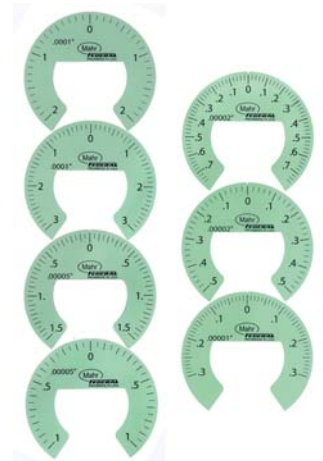

Tooling Adaptors

Adaptors are available for many standard-tooling configurations:

Thread/Adaptor style	Plug Type / Measured size	Order No.
1/4-28	2.7686 mm / .109" to 12.547 mm / .494"	AAD-193* AAD-312
10-32	12.547 mm / .494" to 23.876 mm / .940"	AAD-194* AAD-313
1/2-20	23.876 mm / .940" to 139.7 mm / 5.500"	AAD-195* AAD-314
1/8 Barb	3/8-32 Female	2242767
Setlock	Moore	2242777
8mm	Mahr Row	2240621
12mm	Mahr Row	2240623
9/32-40	Mahr Federal High Mag	

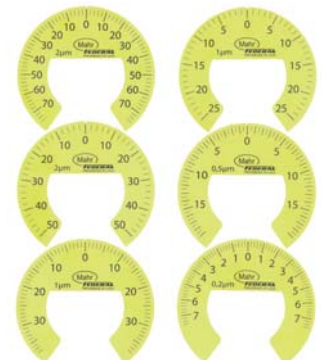

* Includes bleed to simulate MFI jetting.

μDimensionair® (single master system)



The μDimensionair is the ultimate of portability and versatility – in your hand or at the workbench or machine tool.

Features

- **Affordable**
 - **Versatile**
 - **Innovative**
 - **Rugged**
- All other features of the μMaxum Digital Indicator:
- Inch/metric units
 - Digital and analog display
 - Bi- and uni-lateral tolerances with presets
 - Absolute transducer for eliminating travel errors
 - Calibratable – battery retains settings
 - Multiple data output formats
 - Auto-zeroing
 - Normal-reverse settings for ID/OD measurements
- No other air gaging system offers so much – in the palm of your hand – mounted to the workbench or even right to the machine tool. μDimensionair is rated IP54, so, it can be used on the shop floor – and, the air tooling cleans dirt from the part for high performance measurements – fast and easy!
 - Air gage readout is right in front of you – simple and clear.
 - Fixed resolution and balanced air system makes the gage stable and reliable for your manufacturing environment.
 - Single mastering for fast setup.

Technical Data

Measuring Range mm/inch	Digital Resolution mm/inch	Tooling I.D. Number
± 0.080/ ± 0.003"	0.001/ 0.00005"	60
± 0.040/ ± 0.0016"	0.0005/ 0.00002"	50
± 0.020/ ± 0.00076"	0.0005/ 0.00002"	20

Operating Temperature	5 - 35° C / 41 - 95° F
Storage Temperature	0 - 60° C / 32 - 140° F
Repeatability	± 1 digit
Calibration Accuracy	± 1 digit
Linear Error	± 1 digit
Response Time	Approximately 1 second
Thermal Stability	0.1% of full scale/F
Data Output	ASCII/Digimatic
Tolerance Indicators	Two – over/under
Weight	25 kg / 5lbs.
Dimensions - Main body	approx. 100 x 60 x 70 mm approx. (4" x 2.5" x 3")
Auto Power Off	15 minutes of non-use
Power Requirements	3 volt lithium battery coin cell, 2 per unit – CR-2450
Battery Life	9 months normal usage – 3000 hours
Air Supply	2.10 ± .01 bar / 30.4 ± .15 psi
Display	Rotates through 270 degrees

Order no.

	Order no.
μDimensionair, complete with handle, adaptor and hose	2095389

Accessories

	Order no.
Pressure Regulator with filter	2238020*
Pressure Meter	2095924
Bench Kit with adaptor	2239307
Output cable – Digimatic	2001025
Serial output cable to DB-9 pin	SCB-4
Battery 3V type CR-2450	EBY-1018
Insulated Handle	2237666
Shut off valve	2240993
Rest Stand	2241109
Swivel Adaptor	2240594
Supply Hose to Regulator/Filter	AHO-2
Oil and Water Trap	AFL-24

* Required

Millimar S 1840 PE (single or dual master system)

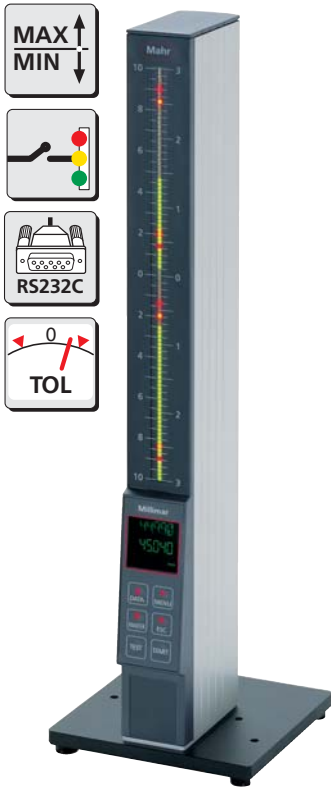

The Millimar S 1840 column amplifier can be programmed either menu-guided via the integrated membrane keypad or with the provided MS Windows® configuration software.

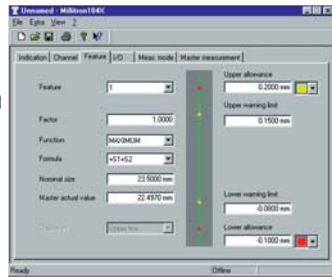

Features

Assess and judge measuring results at a glance – nothing is easier than that with the Millimar S 1840 column amplifier.

The Millimar S 1840 column amplifier offers a broad range of functions for combining the signals from both static and dynamic measurements.

Measuring results are indicated by way of 101 three-color LEDs. When the programmable warning and tolerance limits are exceeded, the LEDs change their color from green to yellow or red, accordingly – high visibility from any distance.

Display

- Three-color illuminated bar graph with analog warning and tolerance limit display
- Two-line backlit LCD for indicating measured values, help texts, and measuring units
- Up to two characteristics can be displayed simultaneously.

Functions

- Static measurements: $\pm A$, $\pm B$, and all combinations.
 - Dynamic measurements: Max, Min, Max-Min, Max+Min, mean.
 - Windows® software for configuring the LED display
- The Millimar S 1840 column amplifier can be programmed either menu-guided via the integrated membrane keypad or with the provided MS Windows® configuration software.
- Single Master or Dual Master setup.
 - Password lockout in Setup Mode.

Connections

- Single input.
- RS 232 interface.
- Analog output.
- Three digital inputs for measuring start, master measurement, etc.
- Three digital outputs for Accept – Reject – Rework classification, measuring time, etc.

Technical Data

Air/electronic converter for Millimar S 1840 PE

Measuring principle	differential pressure		
Measuring value acquisition	piezo		
Magnification	2500:1	5000:1	10000:1
Pneumatic measuring range in μm (inch)	± 50	± 25	± 12.5
Resolution	($\pm 00196''$ $\pm 00098''$ $\pm 00049''$)		
Measuring error in μm (inch)	< 1 % of measuring range, better 0.5 %		
Signal noise in μm (μinch)	≤ 0.4 (15.748)	≤ 0.2 (7.874)	≤ 0.1 (3.937)
Setting time in sec. (1 m / 3.3 ft hose)	≤ 0.3	≤ 0.3	≤ 0.5
Setting time in sec. (2 m / 6.6 ft hose)	≤ 0.5	≤ 0.5	≤ 0.7
Operating temperature	0 ... 40 °C (32 ... 104 °F)		
Supply pressure (> 4 bar before pressure reducer)	2 bar \pm 5 %		
Air supply connection	PU hose, dia 8 x 1 (.315 x .0394'')		
Measuring air connection	PU hose, dia. 6 x 1 (.236 x .0394'')		
Zero setter (OFFSET)	electrical		
Amplification (GAIN)	electrical		
Air consumption	approx. 1-2 m ³ approx. (1.308-2.616 cu.yd.)		

Order no.

Order no.

Millimar S 1840 PE/F

for 1 Air Gage 2500:1 / 5000:1 without Regulator
for 1 Air Gage 10000:1 without Regulator

5330104*
5330106*

* Base with Regulator required and sold separately.
Air Supply Kit recommended.

Accessories

Order no.

Basefoot

With 1 Regulator for 1 1840 PE Column Unit
With 2 Regulators for 2 1840 PE Column Units
With 3 Regulators for 3 1840 PE Column Units

5330910
5330911
5330912

Air Supply Adaptor Kit

Includes AFL-24 Filter and AHO-2 Hose

2121236

832 Dimensionair® Air Gaging System (single master system)



Features

- Digital and analog displays in a single unit. Large, high contrast digital readout shows exact deviation from zero; analog display shows measurement conditions at a glance.
- Dynamics measurement capability.
- Fixed resolution and balanced air system makes the Digital Dimensionair a stable and reliable system for manufacturing environments.
- Only a single master required to set zero; system is precalibrated for correct magnification.
- Ranges and resolutions for virtually any air gage application, including 2-, 3-, 4- and 6-jet tooling plus AirProbes and JetProbes.
- RS-232 Output – for communicating with a data collector, computer or printer, permitting statistical process control.
- Master Deviation – enhances measurement by making Auto Zero even more accurate.

Technical Data

Model	Measuring Range	Digital Resolution	Analog Resolution	Tooling I.D. Number
Low Magnification Single or Dual Input	±0.080 mm/ ±003"	0.0002 mm/ 10µ"	0.004 mm/ 150µ"	60
	±0.040 mm/ ±0015"		0.002 mm/ 75µ"	50
	±0.020 mm/ ±00075"		0.001 mm/ 38µ"	20
High Magnification Single or Dual Input	±0.008mm/ ±0003"	0.0001 mm/ 5µ"	0.0004 mm/ 15µ"	10
	±0.004mm/ ±00015"		0.0002 mm/ 8µ"	5

Number of Jets	Voltage/Adaptor	Low Magnification Single Input Order no.	High Magnification Single Input Order no.	Low Magnification Dual Input Order no.	High Magnification Dual Input Order no.
1, 2, 3	110 / U.S.	2004100	2004103	2004106	2004109
4	110 / U.S.	2004101	2004104	2004107	2004110
6	110 / U.S.	2004102	2004105	2004108	2004111
1, 2, 3	240 / International	2004112	2004115	2004118	2004121
4	240 / International	2004113	2004116	2004119	2004122
6	240 / International	2004114	2004117	2004120	2004123

Millimar C 1208 PE / C 1245 PE (single or dual master system)



1208 PE



C 1245 PE

Features

C1208 PE Display

- Background lit LCD-Display with an analog and a two line digital display
- 5 three-color status lamps for warning and tolerance limits
- Up to 2 characteristics can be displayed at the same time.

C1208 PE Functions

- Favorites, frequently required functions can be assigned to the SELECT key
- Static measurements $\pm A$, $\pm B$ and all combinations
- Dynamic measurements: Max, Min, Max-Min, Max+Min, mean

C1245 PE Display

- Analog indicator instrument for display of measurement value.
- Two-line LCD display for values and menu text
- 5 three-color status lamps for warning and tolerance limits.
- Up to 3 characteristics can be displayed at the same time.

C1245 PE Functions

- 16 characteristics can be defined using an equation editor (80 characters), input channels C1 to C8 are mathematically linked with factors and brackets using the 4 basic mathematical functions.
- Static measurements: Current value, square root, arc tangent.
- Dynamic measurements: Max, Min, Max-Min, Max+Min, Mean value.
- Statistical functions: n, x-bar, S, Xmax, Xmin, R.
- Measured value memory for 5000 measured values.
- Measurement start / stop via keyboard, digital input, RS232.

Technical Data

		Order no.
Millimar C 1208 PE/F	For 1 Air Gage 2500:1 / 5000:1 with Regulator	5312095
Millimar C 1208 PE/F	For 1 Air Gage 10000:1 with Regulator	5312093
Millimar C 1245 PE/F	For 1 air gage 2500:1 / 5000:1 with Regulator	5331271
Millimar C 1245 PE/F	For 1 air gage 10000:1 with Regulator	5331273
Millimar C 1245 PE/F2	For 2 air gages 2500:1 / 5000:1 without Regulator	5331275*
Millimar C 1245 PE/F2	For 2 air gages 10000:1 without Regulator	5331277*
Air Supply Adaptor Kit	includes AFL-24 Filter and AHO-2 Hose	2121236
* Baseplate with 2 Regulators	(required for 2 Air Gage Units)	5330909

Air Plugs

Features

- **Calibrated I.D. tooling for the Dimensionair® Air Gaging Systems**
- Tooling is interchangeable without adjusting system magnification.
- Federal Air Plugs have large clearance (see table below), allowing easy entrance into the hole being measured and greater measuring range.
- Long life - wide clearance and high chrome stainless steel body extends useful life of the Air Plug. Chromed steel or other materials for extreme use are available.
- Deep, recessed jets - Air jets are recessed into the plug body which protects them from damage.
- Large jet size eliminates clogging from dirt and oils.

Plug identification



Air Plugs are marked with an identification number which identifies its size, number of jets, plug style, and the Dimensionair® Model the plug should be used with.

For example: **DP50-T2-1.000** is the identification number of an Air Plug for a **2095184** or a standard magnification 832 Dimensionair (DP50), through-hole style with two jets (-T2), and 25 mm/1.000" nominal size (-1.000).

The number (50) which identifies the Dimensionair intended is marked on the plug and also appears on the dial of the Dimensionair to help in matching the tooling to its corresponding Dimensionair Model.

Total Clearance from Nominal Size

Plug Identification	Nominal Size mm/ <i>inch</i>	To & include above mm/ <i>inch</i>	Clearance from Nominal Size mm/ <i>inch</i>
DP100, DP60	6.3/ .248"	76.4/ 3.004"	0.081/ .0032"
DP50	3/ .123"	3.5/ .140"	0.015/ .0006"
	3.5/ .140"	4.7/ .185"	0.027/ .0011"
	4.7/ .185"	6.3/ .248"	0.030/ .0012"
	6.3/ .248"	76.5/ 3.004"	0.045/ .0018"
	76.5/ 3.004"	127/ 5"	0.071/ .0028"
	Above 127/ 5"		0.081/ .0032"
DP20	3/ .123"	3.5/ .140"	0.009/ .00035"
	3.5/ .140"	4.7/ .185"	0.013/ .0005"
	4.7/ .185"	6.3/ .248"	0.015/ .0006"
	6.3/ .248"	76.5/ 3.004"	0.023/ .0009"
	76.5/ 3.004"	127/ 5"	0.071/ .0028"
	Above 127/ 5"		0.081/ .0032"
DP10	All sizes to 1.75	44.45/ 1.750" up	0.009/ .00035" 0.014/ .00055"
DP5	All sizes to 1.0 1.75	25.4/ 1.0" up	0.004/ .000175" 0.005/ .0002" 0.0076/ .0003"

Ordering Information

When ordering Air Plugs please specify:

1. Nominal I.D. Size and Tolerance.
2. Dimensionair Model to be used.
3. Air Plug style (Through Hole, Blind Hole, or Counterbore).
4. Air Plug finish (Normally furnished High Chrome stainless steel, or specify chromed steel).
5. Order Master Setting Ring at same time.

Unless otherwise specified, Mahr Federal will furnish a 2-jet, Through Hole, High Chrome Air Plug for a 2500:1 Dimensionair.



Through Hole and Blind Hole Air Plugs

Through Hole Plugs (DP50 - DP20 & 60)

3-3.5 mm / .123-.140"

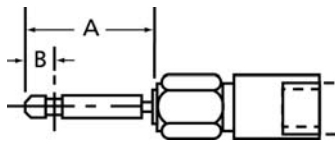

Minimum recommended hole length: .187"

9.5-14.93 mm / .3735-.588"

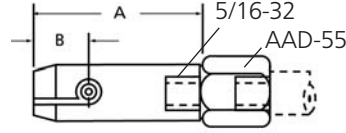

Minimum recommended hole length: .250". With guide sleeve or stop collar: .070". May be used with AEX-1 or -2 Extensions for deep holes.

3.5-4.7 mm / .140-.185"

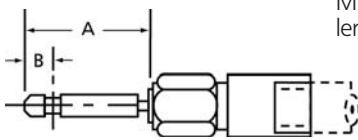

Minimum recommended hole length: .187"

14.93-37.7 mm / .588-1.484"

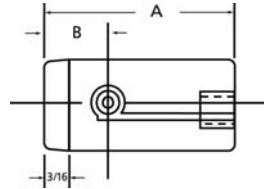

Minimum gageable hole length: .250". With guide sleeve or stop collar: .070". May be used with AHA-4 or -5 Extensions for deep holes.

4.7-6.3 mm / .185-.248"

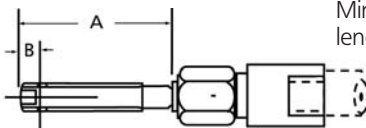

Minimum recommended hole length: .187"

37.7-76.3 mm / 1.484-3.004"

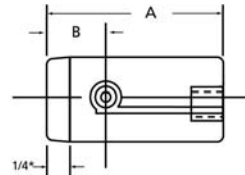

Minimum recommended hole length: .250". With guide sleeve or stop collar: .070". May be used with AHA-4 or -5 Extensions for deep holes.

6.3-9.5 mm / .248-.3735"

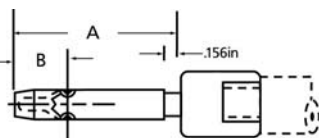

Minimum recommended hole length: .250"
With guide sleeve or stop collar: .070"

76.3-114.3 mm / 3.004-4.50"

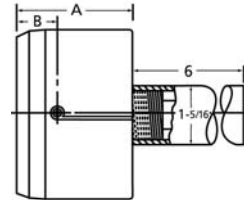

Minimum recommended hole length: .250".
With guide sleeve or stop collar: .070".

Technical Data

Through Hole Plugs

Above	To & include	"A"	"B"	Minimum Hole Length*	Measuring Range	
mm/ <i>inch</i>	mm/ <i>inch</i>	mm/ <i>inch</i>	mm/ <i>inch</i>	mm/ <i>inch</i>	DP50 mm/ <i>inch</i>	DP20 mm/ <i>inch</i>
3 / .123"	3.5 / .140"	23.8 / .9375"	4.8/ .1875"	4.7/ .187"	0.025/ .001"	0.013/ .0005"
3.5 / .140"	4.7 / .185"	23.8 / .9375"	4.8/ .1875"	4.7/ .187"	0.038/ .0015"	0.020/ .00075"
4.7 / .185"	6.3 / .248"	38 / 1.5"	12.7/ .500"	4.7/ .187"	0.051/ .002"	0.025/ .001"
6.3 / .248"	9.5 / .3735"	38 / 1.5"	12.7/ .500"	6.4/ .250"	0.076/ .003"	0.038/ .0015"
9.5 / .3735"	14.93 / .588"	38 / 1.5"	12.7/ .500"	6.4/ .250"	0.076/ .003"	0.038/ .0015"
14.93 / .588"	37.7 / 1.484"	41.3 / 1.625"	15.9/ .625"	6.4/ .250"	0.076/ .003"	0.038/ .0015"
37.7 / 1.484"	76.3 / 3.004"	50 / 2"	19/ .750"	6.4/ .250"	0.076/ .003"	0.038/ .0015"
76.3 / 3.004"	114.3 / 4.5"	50 / 2" **	19/ .750"	6.4/ .250"	0.076/ .003"	0.038/ .0015"

* If a guide sleeve or stop collar is used, minimum hole length can be as small as 1.8 mm/.070" for holes larger than 6.3 mm/.248".

** A handle 152 mm/6" long and 33.3 mm/1.31" diameter is supplied with plugs over 76.3 mm/3.004".

Blind Hole/Counterbore Plugs (DP50 - DP20 & 60)

3.9-4.7 mm / .155-.185"

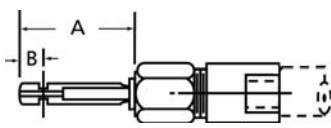

Minimum recommended hole length: .250".
Note: Masters must simulate workpiece for holes of this size.

4.7-6.3 mm / .185-.248"

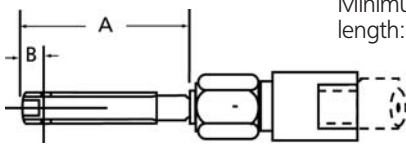

Minimum recommended hole length: .250".

6.3-9.48 mm / .248-.3735"

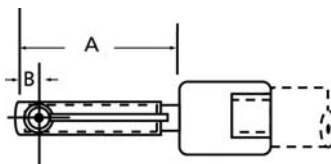

Minimum recommended hole length: .250".
Shorter bores can be checked. Consult Mahr Federal Customer Resource Center.

9.48-11.8 mm / .3735-.467"

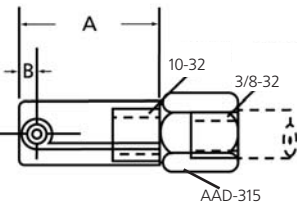

Minimum recommended hole length: .250".
Shorter bores can be checked. Consult Mahr Federal Customer Resource Center. May be used with Extension AHA-28 for deep holes.

11.8-14.93 mm / .467-.588"

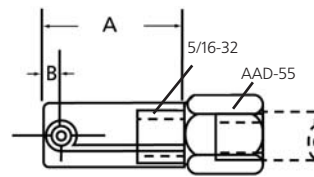

Minimum recommended hole length: .250".
Shorter bores can be checked. Consult Mahr Federal Customer Resource Center. May be used with Extensions AEX-1 or -2 for deep holes.

14.93-37.7 mm / .588-1.484"

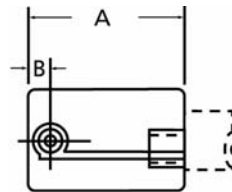

Minimum recommended hole length: .250".
Shorter bores can be checked. Consult Mahr Federal Customer Resource Center. May be used with AHA-4 or -5 Extensions for deep holes.

37.7-76.30 mm / 1.484-3.004"

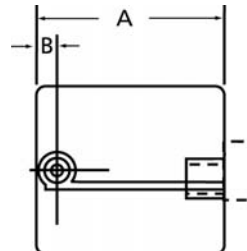

Minimum recommended hole length: .250".
Shorter bores can be checked. Consult Mahr Federal Customer Resource Center. May be used with AHA-4 or -5 Extensions for deep holes.

76.3-108.114.3 mm/3.004-4.50"

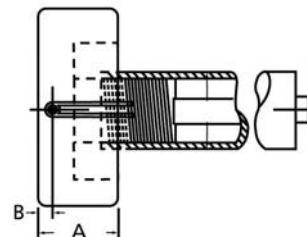

Minimum gageable hole length: .250".

Technical Data

Blind Hole/Counterbore Plugs

Above	To & include	"A"	"B"	Minimum Hole Length*	Measuring Range	
mm/inch	mm/inch	mm/inch	mm/inch	mm/inch	DP50	DP20
					mm/inch	mm/inch
3.9/ .155"	4.7/ .185"	19/ .750"	4/ .156"	6.4/ .250"	0.038/ .0015"	0.01905/ .00075"
4.7/ .185"	6.3/ .248"	29.4/ 1.156"	4/ .156"	6.4/ .250"	0.051/ .002"	0.025/ .001"
6.3/ .248"	11.8/ .467"	29.4/ 1.156"	4/ .156"	6.4/ .250"	0.076/ .003"	0.038/ .0015"
11.8/ .467"	14.93/ .588"	29.4/ 1.156"	4/ .156"	6.4/ .250"	0.076/ .003"	0.038/ .0015"
14.93/ .588"	37.7/ 1.484"	29.4/ 1.156"	4/ .156"	6.4/ .250"	0.076/ .003"	0.038/ .0015"
37.7/ 1.484"	76.3/ 3.004"	35.7/ 1.406"	4/ .156"	6.4/ .250"	0.076/ .003"	0.038/ .0015"
76.3/ 3.004"	114.3/ 4.5"	38/ 1.5"	4/ .156"	6.4/ .250"	0.076/ .003"	0.038/ .0015"

* A handle 152 mm/ 6" long and 33.3 mm / 1.31" diameter is supplied with plugs over 76.3 mm / 3.004"

Super Blind Plugs

Blind Hole Air Plugs can be furnished to check shorter holes than listed, and can be furnished to check closer to the bottom of a hole. Holes must be at least 2.8 mm/ .110" long, and the distance from the end of the plug to the center-line of the jets can be as short as 2.2 mm/ .085" for plugs below 6.3 mm/ .248" or 1.9 mm/ .075" for plugs above 6.3 mm/ .248".

Contact Mahr Federal Customer Resource Center with your requirements

Through Hole Plug (DP10 – DP5)

1.6-6.4 mm / .062-.250"

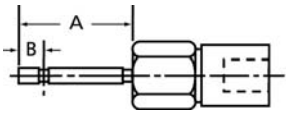

Minimum recommended hole length: 3.18 mm / .125".

6.4-9.5 mm / .250-.3735"

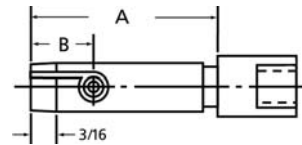

Minimum recommended hole length: 3.18 mm / .125".
With guide sleeve or stop collar: 1.14 mm / .045".

9.5-11.1 mm / .3735-.437"

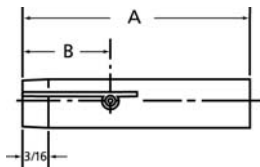

Minimum recommended hole length: 3.8 mm / .125".
With guide sleeve or stop collar: 1.14 mm / .045". May be used with AHA-23 or -24 Extensions for deep holes.

11.1-44.5 mm / .437-1.750"

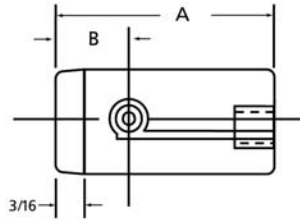

Minimum recommended hole length: 3.18 mm / .125" with proper support min. is 1.14 mm / .045". May be used with AHA-23 or -24 Extensions for deep holes.

44.5 mm & Up / 1.750" & Up

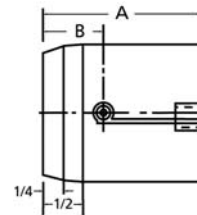

Minimum recommended hole length: 3.18 mm / .125".
With guide sleeve or stop collar: 1.14 mm / .045". May be used with AHA-23 or -24 Extensions for deep holes.

Through Hole Plugs

Measured Size mm/inch

Above		To & include		"A"		"B"		Minimum Hole Length*		Measuring Range	
mm	/ inch	mm	/ inch	mm	/ inch	mm	/ inch	mm	/ inch	DP10	DP5
1.6	/.062"	6.4	/.250"	23.8	/.9375"	4.8	/.1875"	3.2	/.125"	0.015	/.0006"
6.4	/.250"	9.5	/.3735"	38	/ 1.5"	12.7	/.500"	3.2	/.125"	0.015	/.0006"
9.5	/.3735"	11.1	/.437"	41.3	/ 1.625"	15.9	/.625"	3.2	/.125"	0.015	/.0006"
11.1	/.437"	44.5	/.1.750"	41.3	/ 1.625"	15.9	/.625"	3.2	/.125"	0.015	/.0006"
44.5	/.1.75"	76.5	/.3.010"	50	/ 1.9685"	19	/.750"	3.2	/.125"	0.015	/.0006"

Blind Hole Plug (DP10 – DP5)

3.2-6.4mm / .125-.250"

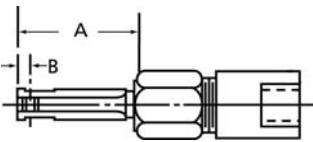

Minimum recommended hole length: 3.96 mm / .156".

6.4-11.1mm / .250-.437"

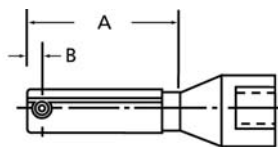

Minimum recommended hole length: 3.18 mm / .125".

11.1mm & Up / .437" & Up

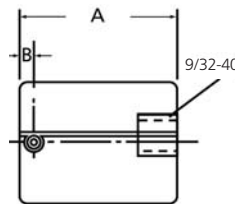

Minimum recommended hole length: 3.18mm / .125".
Use AHA-23 or -24 Extensions for deep hole applications.

Super Blind Plugs

See previous page for more information

Blind Hole/Counterbore Plugs

Measured Size mm/inch

Above		To & include		"A"		"B"		Minimum Hole Length*		Measuring Range	
mm	/ inch	mm	/ inch	mm	/ inch	mm	/ inch	mm	/ inch	DP10	DP5
3.2	/.125"	6.4	/.250"	21.4	/.844"	2.4	/.094"	3.9	/.156"	0.015	/.0006"
6.4	/.250"	11.1	/.437"	27.8	/ 1.094"	2.4	/.094"	3	/.120"	0.015	/.0006"
11.1	/.437"	76.5	/.3.010"	27.8	/ 1.094"	2.4	/.094"	3	/.120"	0.015	/.0006"

* If a guide sleeve or stop collar is used, minimum hole length can be as small as 1.1 mm / .045" for holes larger than 6.4 mm / .250".

Through Hole Plug (DP100)

1.6-6.4 mm / .062-.250"

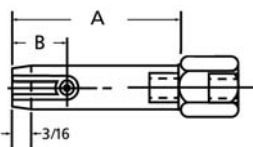

Minimum recommended hole length: 6.35 mm / .250", with proper support min. is 3.18 mm / .125in. May be used with AEX-1 or -2 Extensions for deep holes.

37.8-76.5mm / 1.490-3.004"

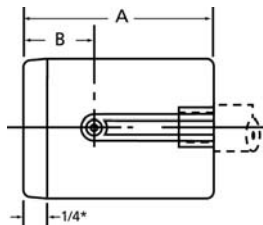

Minimum recommended hole length: 6.35 mm / .250".

May be used with AHA-4 or -5 Extensions for deep holes.

12.7-37.8mm / .500-1.490"

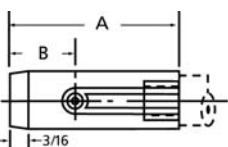

Minimum recommended hole length: 6.35 mm / .250", with proper support min. is 1.14 mm / .125". May be used with AHA-4 or -5 Extensions for deep holes.

76.5mm & Up / 3.004" & Up

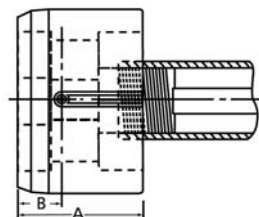

Minimum recommended hole length: 6.35 mm / .250".

Through Hole Plugs

Measured Size mm/inch

Above		To & include		"A"		"B"		Minimum Hole Length*		Measuring Range DP10		DP5	
mm	/ inch	mm	/ inch	mm	/ inch	mm	/ inch	mm	/ inch	mm	/ inch	mm	/ inch
9.525	/.375"	12.7	/.500"	38	/ 1.5"	12.7	/.500"	12.7	/.500"	6.4	/.250"	0.152	/.006"
12.7	/.500"	37.8	/.490"	41.3	/.625"	15.9	/.625"	15.9	/.625"	6.4	/.250"	0.152	/.006"
37.8	/.490"	76.5	/.3004"	50	/ 2"	15.9	/.625"	19	/.750"	6.4	/.250"	0.152	/.006"
76.5	/.3004"	114	/.45"	50	/ 2"	19	/.625"	19	/.750"	6.4	/.250"	0.152	/.006"

Blind Hole/Counterbore Plugs

9.525-14.25 mm / .375-.561"

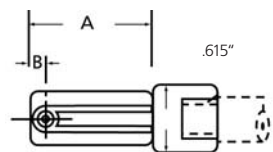

Minimum recommended hole length: 7.9 mm / .312".

14.25-37.8 mm / .561-1.490"

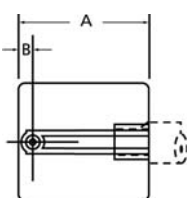

Minimum recommended hole length: 7.9 mm / .312". Use with AHA-4 or -5 handles for deep hole applications.

37.8-76.3 mm / 1.490-3.004"

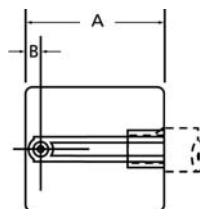

Minimum recommended hole length: 7.9 mm / .312". Use with AHA-4 or -5 handles for deep hole applications.

Super Blind Plugs

Blind Hole Air Plugs can be furnished to check shorter holes than listed above, and can be furnished to check closer to the bottom of a hole. Holes must be at least 4.45 mm / .175" long, and the distance from the end of the plug to the center-line of the jets can be as short as 2.5 mm / .100".

76.3-108.2 mm / 3.004-4.500"



Notes:

* If a guide sleeve or stop collar is used, minimum hole length can be as small as 1.8 mm / .070" for holes larger than 6.3 mm / .248"

** A handle 152 mm / 6" long and 33.3 mm / 1.31" diameter is supplied with plugs over 76.5 mm / 3.010".

For smaller or larger plugs than those shown above, or for any modification to the specifications shown, contact Mahr Federal Customer Resource Center.

Blind Hole Plugs

Measured Size mm/inch

Above		To & include		"A"		"B"		Minimum Hole Length*		Measuring Range	
mm	/ inch	mm	/ inch	mm	/ inch	mm	/ inch	mm	/ inch	mm	/ inch
9.525	/.375"	14.1	/.556"	30	/ 1.187"	4.7	/.187"	12.7	/.500"	0.152	/.006"
14.1	/.556"	37.8	/.490"	30	/ 1.187"	4.7	/.187"	15.9	/.625"	0.152	/.006"
37.8	/.490"	76.5	/.3004"	36.5	/.438"	4.7	/.187"	19	/.750"	0.152	/.006"
76.5	/.3004"	114	/.45"	36.5	/.438"	4.7	/.187"	19	/.750"	0.152	/.006"

Air Gaging Instruments

Accessories

Handles and Extensions

When an Air Plug is used with a hose, it should be equipped with a Handle to avoid excessive strain on the air connection and corrosion on the polished plug body. Handles may be combined for gaging deep holes.

Selection of a handle or extension is determined by the bore itself and whether or not it is preceded by a larger C-bored diameter. Corresponding thread sizes of the handle or extension must also be considered.

If no portion of the handle or extension enters the part, only thread sizes must be considered. If the plug does enter the part, then both O.D. and thread size must be considered.

AHA-4 and AHA-5 Extensions — accept AHO-1 Hose on one end and the following plug sizes on the opposite end: all 1250:1 thru 8000:1 plugs up to 76.3 mm / 3.004".

AHA-6 Handle — accepts AHO-1 Hose on one end and the following plug sizes on the opposite end: all 1250:1 thru 8000:1 plugs up to 76.3 mm / 3.004". Has Bakelite insulating cover. Recommended for 37.7 mm / 1.484" up to 76.3 mm / 3.004" diameters.

2237666 — High impact and coolant resistant, light weight composite handle — normally furnished with uDimensionair and air snaps.

AHA-66 and 2236070 — light weight aluminum handles without or with air shutoff valve.

AHA-15 Handle — Used and furnished with 1250:1 thru 8000:1 through or blind hole plugs over 76.3 mm / 3.004".

AHA-23 and AHA-24 Handles — Used with 10000:1 thru 32000:1 plugs.

AHA-28 Handle — Used with 2500:1 thru 8000:1 blind hole plugs in the 9.48 mm / .3735" to 11.8 mm / .467" range, using an AAD-315 Adaptor.

AEX-1 and AEX-2 Extensions — Used with 2500:1 thru 8000:1 through hole air plugs in the 9.5 mm / .3735" to 14.93 mm / .588" range and with 11.8 mm / .467" to 14.93 mm / .588" range blind hole plugs, using an AAD-55 Adaptor.

2201975 — extension used with BA-100 adjustable base. Provides easily configured base for bench-mounted air tooling fixturing. See Dimention Plugs (Chapter 9. MaraMeter).

Accessory Configuration for DP60/DP50/DP20 Systems — Low Magnification

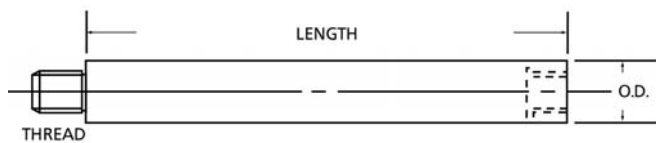
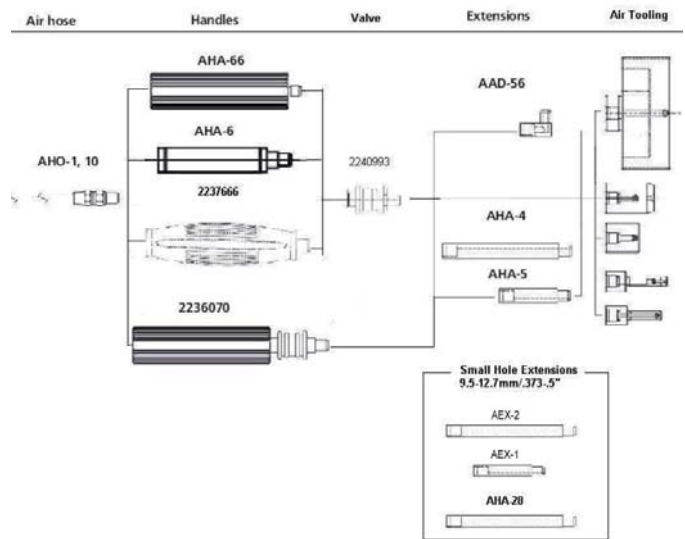

Order no.	Thread	O.D. mm/ <i>inch</i>	Length mm/ <i>inch</i>
AHA-4	3/8-32	12.07/ .475"	102/ 4"
AHA-5	3/8-32	12.07/ .475"	51/ 2"
AHA-6	3/8-32	19/ .750"	102/ 4"
AHA-15	1-1/8-18	33.4/ 1.315"	152/ 6"
AHA-20	3/8-32	12.7/ .500"	133.3/ 5.25"
AHA-23	9/32-40	9.14/ .360"	51/ 2"
AHA-24	9/32-40	9.14/ .360"	102/ 4"
AHA-28	10-32	9.14/ .360"	102/ 4"
AEX-1	5/16-32	9.02/ .355"	51/ 2"
AEX-2	5/16-32	9.02/ .355"	102/ 4"
2201975*	3/8-32	9.5/ .374"	61.7/ 2.43"

Accessories for High Magnification Systems — DP10/DP5

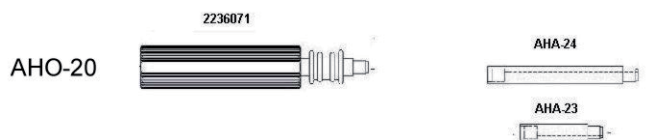

* Use on BA-100

Dimensionair® Air Rings

Air rings are supplied in several styles for external measuring. Two and three jet rings are most common, used for checking outside diameters for sizes out of round conditions from 6.3 mm / .248" to 63.5 mm / 2.500". Four and six jet rings are also available for special applications. All Air Rings have chrome-plated wear surfaces unless otherwise specified.

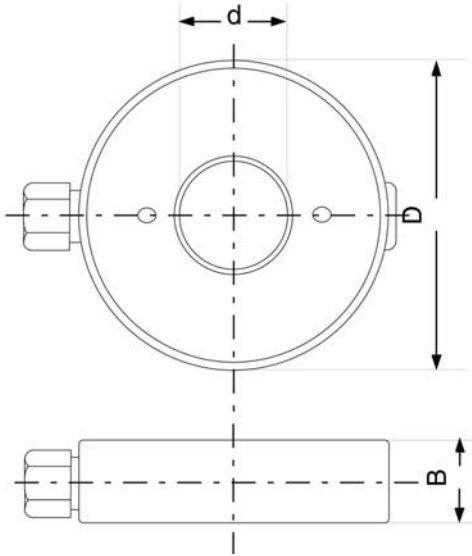

Jet air ring gage with 2 measuring jets

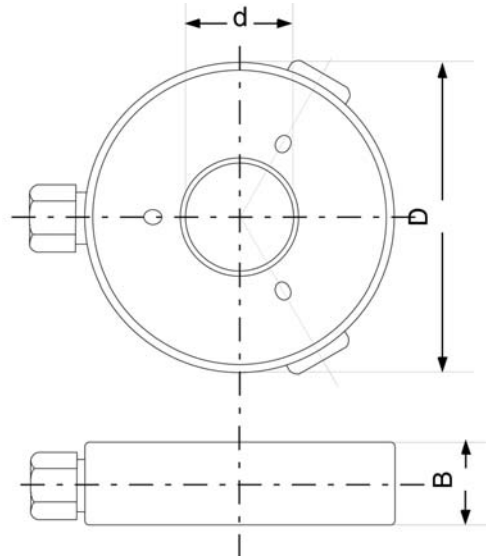

Jet air ring gage with 3 measuring jets

For applications where O.D.'s need to be checked near a shoulder, or where part length is restricted, contact Mahr Federal for technical assistance about shoulder and Snout Type Air Rings.

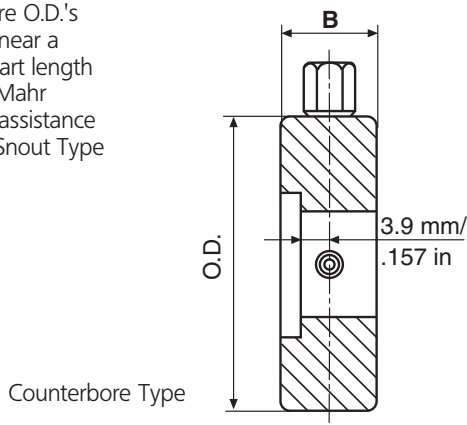

Counterbore Type

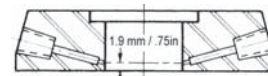

Shoulder Type
(for 2500:1 & 4000:1
5000:1 & 8000:1 only)

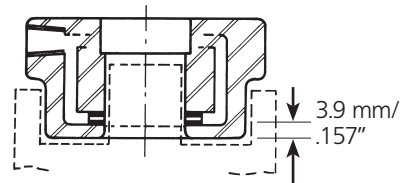

Snout Types

Technical Data

Diameter d mm/ <i>inch</i>	Diameter D mm/ <i>inch</i>	Width B mm/ <i>inch</i>
6.3-7.6/ .248-.299"	76.2/ 3.00"	25.4/ 1.00"
7.6-9.3/ .299-.366"	76.2/ 3.00"	25.4/ 1.00"
9.3-13.0/ .366-.512"	76.2/ 3.00"	25.4/ 1.00"
13.0-21.0/ .512-.827"	76.2/ 3.00"	25.4/ 1.00"
21.0-25.4/ .827-1.00"	76.2/ 3.00"	25.4/ 1.00"
25.4-38.4/ 1.00-1.51"	101.6/ 4.00"	25.4/ 1.00"
38.4-44.5/ 1.41-1.75"	101.6/ 4.00"	25.4/ 1.00"
44.5-50.8/ 1.75-2.00"	127.0/ 5.00"	25.4/ 1.00"
50.8-63.5/ 2.00-2.50"	127.0/ 5.00"	25.4/ 1.00"
63.5-76.2/ 2.50-3.00"	139.7/ 5.00"	25.4/ 1.00"

When ordering ring gages, please specify the following:

- Nominal workpiece dimensions
- Tolerance
- Desired magnification
- Instrument used
- Setting plug to be supplied?

Air Rings may be attached directly to a Dimensionair or used on a base and connected to the gage with a plastic hose. Vee type Guide Chutes can be furnished on one or both sides if Air Rings from 6.3 mm / .248" through 44.5 mm / 1.750". Tube type guide can be furnished on sizes from 6.3 mm / .248" through 63.5 mm / 2.500".

Dimensionair® Air Rings

Options for Air Rings

Carbide Wear strips

Air plugs are normally furnished chromed for long life. Other materials can be provided to improve the life of the ring when high volume or grinding grit may still remain on the part. Materials such as Ferrotic and addition of carbide strips can be provided.

Bases for air rings

Depending on the application there are many ways to hold an air ring. They may be hand held and placed over the part if the part is still on the machine. They may be front mounted, horizontally or vertically on the Dimensionair or for larger parts they can be mounted to a base and held vertically or horizontally. Special bases are available to mount the ring horizontally and incorporate a part lifting mechanism to aid in part removal.

Guide chutes

Guide chutes and vees are available in a host of options to improve the inspection process. Vee type guide chutes can be furnished on one or both sides of an air ring from 6.3mm/ .248" through 44.5mm/ 1.75". Other options include tube type guide chutes for sizes 6.3mm/ .248" through 63.5mm/ 2.5". Standard length of the guide chutes are 6.3mm/ 2.5" and affix to the side of the air ring. Normal length of the chute is 6.3mm/ 2.5". Other options including heavy duty out riggers and universal vee stands can be provided.



Options for Air Snaps

Since side clearances can present gaging problems with crankshaft diameters or similar applications, Mahr Federal designed a new line of air snaps that make the tough measurements easier and affordable.

We based our new air snap design on our own proven air tooling techniques, known for providing long life and high-resolution in tough shop environments. Now you can measure fixed sizes from 12.5 mm/ .49" through 184 mm/ 7.25" using D-2500 and D-5000 systems. Widths are typically 19 mm/ .75" but can be customized to reach diameters having tight clearances.

Jet locations can be located central in the snap or positioned close to either side for exploring close to a shoulder.

Multiple circuit air snaps are available for speeding the process while checking the journal for size variation, taper, barrel or hourglass shape.



Dimensionair® Air Gages

AirProbes and JetProbes

- AirProbes and JetProbes provide modular, convenient gage heads for use in hand-held gages and for designing into fixture gages.
- 9.5 mm/.375" bodies provide standardized mounting configurations.
- Compact size allows easy access to hard-to-reach dimensions.
- AirProbes and JetProbes are calibrated for instant use with Dimensionair® systems - just set zero and measure!
- Available in single-probe and matched-probe configurations.



AA-1-3 AirProbe and AAT-19 JetProbe Assembly

AirProbes

For use where contact-type measurement is required with 2500:1 Dimensionair Systems. AirProbes are available in Regular Action (counter-clockwise meter movement when spindle is depressed) or Reverse Action (clockwise meter movement when spindle is depressed) and in various ranges. When used with Model 2500:1 Dimensionair, the Meter Dial must be specified to match the

AirProbe range (see table below). AirProbe and Dial are color coded - just match the color band on the AirProbe to the colored dot on the Dial to be sure that the AirProbe range matches the readout on the Dimensionair. AirProbes are provided with AAD-55 Straight Adaptor for attaching to Air Hoses.

Order No.	Range		Style / Color Code***	Matching Dial Model		Graduations	
	mm	inch		inch	metric	µm	inch
AA-1-3*	0.076	.003"	Regular / Red	ADL-28**	ADL-95**	1	.00005"
AA-2-3*	0.076	.003"	Reverse / Red	ADL-28**	ADL-95**	1	.00005"
AA-1-6	0.152	.006"	Regular / Green	ADL-16	ADL-96	2	.0001"
AA-2-6	0.152	.006"	Reverse / Green	ADL-16	ADL-96	2	.0001"
AA-1-15	0.301	.015"	Regular / Yellow	ADL-20	ADL-97	5	.0002"
AA-2-15	0.301	.015"	Reverse / Yellow	ADL-20	ADL-97	5	.0002"
AA-1-30	0.762	.030"	Regular / Blue	ADL-24	ADL-98	10	.0005"
AA-2-30	0.762	.030"	Reverse / Blue	ADL-24	ADL-98	10	.0005"

* .003" Range AirProbes can also be used with 5000:1 Dimensionairs, but the working range is reduced to .0015".

** These dials are the same as normally supplied on 2500:1 Dimensionairs, except for the color code.

*** Regular AirProbes have single color band; reverse AirProbes have double color band.

AirProbes can be supplied in matched pairs, either two Regular Action AirProbes or one Regular and one Reverse Action AirProbe. Contact Mahr Federal Customer Resource Center to specify.

AirProbes JetProbes

JetProbes are similar to AirProbes, except they have an open jet at the end, instead of a contacting spindle. JetProbes are ideal for measuring flatness of surfaces which cannot be touched, or for building into fixture designs where air gaging is called for. JetProbes can be used with 2500:1, 5000:1 Dimensionairs, and are supplied

singly or in matched pairs. Order No. **AAT-19** for single JetProbe or **AAT-20** for a matched pair. JetProbes are supplied with AHO-1 Air Hose, a zero setting valve, and hardware for mounting to the Dimensionair.

Air Gaging Accessories

Magnification Kits

Magnification Kits provide a means for checking Amplifier accuracy, traceable to the National Institute of Standards and Technology (NIST). Each Kit contains restrictors that provide pressure characteristics at zero and at both ends of the scale, a calibrated dial diagram and a Certification of Calibration.



AMR-12

Order No.	For use with:	Tooling
AMR-SPEC-136	1250:1	DP/DR100
2094182	1260:1	DP/DR60
AMR-12	2500:1/4000:1	DP/DR50
AMR-13	5000:1/8000:1	DP/DR20
AMR-14	10000:1/16000:1	DP/DR10
AMR-15	20000:1/32000:1	DP/DR5

Manifolds

Manifolds allow connecting multiple pieces of air tooling to one Dimensionair. Toggle valves allow activation of the selected tool. Manifolds are compatible with Dimensionairs 1250:1 through 8000:1M Manifolds for use with other Dimensionairs, contact Mahr Federal Customer Resource Center – **1-800-333-4243**.

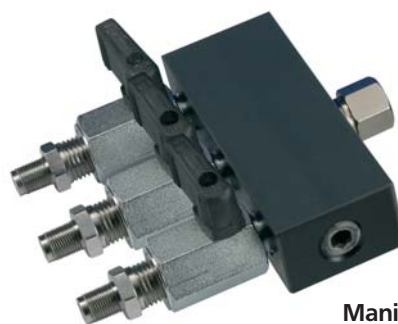

Manifold 2248282

Order No.	Description
2248282	2-way Manifold
2248283	3-way Manifold
2248284	4-way Manifold
2248285	5-way Manifold

Hoses

Supply hoses and hoses between Dimensionair and air tooling.

Order No.	Description	Thread
AHO-2	1.5 m / 5 ft Air Supply Hose. Fits all Dimensionair models. (rubber)	7/16-20
AHO-1	0.9 m / 3 ft Air hose for tooling for Models 1250:1 – 8000:1. (Tygon)	3/8-32
AHO-8	1.5 m / 5 ft Air hose for tooling on Models 1250:1 – 8000:1. (Tygon)	3/8-32
AHO-10	1.8 m / 6 ft Air hose for Models 1250:1 – 8000:1. (Tygon)	3/8-32
AHO-20	0.9 m / 3 ft Air hose for tooling on Models 10000:1 – 32000:1. (Tygon)	9/32-40
ARG-1	Replacement O-ring for AHO-1, -8, -10 Hoses and AHA-4, -5, -6, -20 Handles.	
ARG-6	Replacement O-ring for AHO-20 Hose, AHA-23 and -24 Handles.	
ARG-10	For AEX-1, AEX-2 and AHA-28	

Traps and Filters

Good gaging practice requires clean, dry air for gage performance. Dimensionair Models are furnished with a particle filter. Shop air contains water and oil, which should be removed, using Model **AFL-24** Oil and Water Separator Trap.

Order No.	Description
AFL-10	Particle Filter (normally furnished on all Dimensionair Models). Filter size: 5 microns; Maximum pressure: 250 p.s.i.; maximum working temperature: 175°F.
AFL-24	Oil and Water Separator Trap, includes mounting hardware. Filtering capacity: 99.7% removal of oil and water; filter size: 3-6 microns; maximum pressure: 150 p.s.i.; flow rate: 20 cubic feet of air/minute @ 80 p.s.i.
AFL-23	Replacement cartridge for AFL-24.
AFL-21	Replacement cartridge for AFL-10.
AAD-263	Retrofit Kit for AFL-9



AFL-24 Trap

YOUR STABLE PARTNER FOR MANUFACTURING. **MARSTAND.**



The latest information on MARSTAND products can be found on our website:
www.mahr.com, WebCode 210

▶ | MarStand Indicator Stands, Comparator Stands and Run out Testing Instruments offer high stability which ensures precise measurements. Whether you are using a dial indicator, a dial comparator, a test indicator or a measuring probe you will always have the best possible support. | ◀

▶ | MarStand. Indicator Stands, Comparator Stands, Run out Testing Instruments

Indicator Stands

MarStand 815 GN

With Cast Iron Base

8- 2

MarStand 2400

For Electronic Measurements

8- 2

MarStand 815 MA / 815 MB / 815MG / 815 P

With Magnetic Base

8- 3

Post & Support Arm Assemblies

MarStand 815 XN / 815 XMA / 815 XMB / 815 XMS / 815 XMG / 815 XP

With Mounting Thread and / or T-slot

8- 5

Magnetic Bases

MarStand 815 Y / 815 YP

8- 5

Center Bench

MarStand 818

With moveable Tail Stocks and Support Arms

8- 6

Comparator Stands

MarStand 820 N / 820 NC / 820 FC / 820 NG / 820 FG 35 B / NB-60

Small Version

8- 8

MarStand 821 NG / 821 FG

Large Version

8-12

MarStand 824 NT / 824 FT / 824 GT

Heavy Version

8-13

Modular Units

MarStand 827 b

8-14

Indicator Stand 815 GN

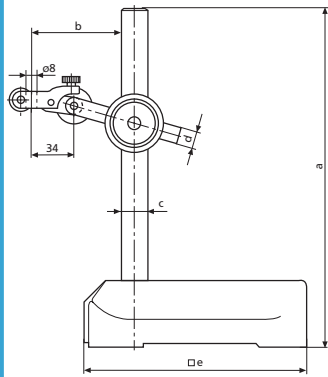

Features

- Rugged base ensures both maximum stability and sturdiness
- The upper side of the base has a convenient hand grip
- Moves easily over surfaces without vibration
- Front of the base is ground to allow movement of the stand along edges and rules
- Stable due to the three point support
- Support arm can be finely adjusted
- Post and support arm are made from stainless steel
- Indicator can be rotated through $\pm 90^\circ$

Technical Data

Total height with base		Max. projection of support arm	Post dia.		Base surface	Fine adjustment range	Weight	Order no.* Mount dia. 8H7	Order no.* Mount dia. 3/8"
a	b		c	d					
mm	inch	mm	mm	mm	mm	mm	kg		
300	12"	185	18	14	150 x 150	2	4.2	4413000	4413050
500	20"	200	25	18	190 x 180	2	9	4413001	4413051
750	30"	230	35	25	190 x 180	2	10	4413005	4413052

* excludes indicating instrument

Indicator Stand 2400



Features

- A stable Height Stand for electronic measurement,
- Fine adjustment in the base allows easy operator set-up, even at high magnification. Up to 3.8 mm / .150" adjustment when arms fully extended.
- Collar has Teflon bearings and metal-to-metal clamping.
- Post is thermally isolated from heat transfer from the base.
- Arm lock is independent of the pivot lock.
- Uses vertical lug mounting
- EHE-2056 Lever gage head mounts directly to arm (as shown) EHE-2048 Lever gage head requires an EAM-1071 adaptor
- CP-83 Extra arm and swivel clamp assembly (allows mounting two lever gage heads on one stand)

Technical Data

Total height with base mm / inch	Arm reach mm / inch	Post dia. force mm / inch	Base surface mm / inch	Fine adjustment range mm / inch	Order no.*
457 / 18"	254 / 10"	31.8 / 1.25"	161.7 x 94 / 6.2 x 3.7"	3.8 / 1.5"	2400

* excludes indicating instrument

Indicator Stand 815 MA with magnetic base

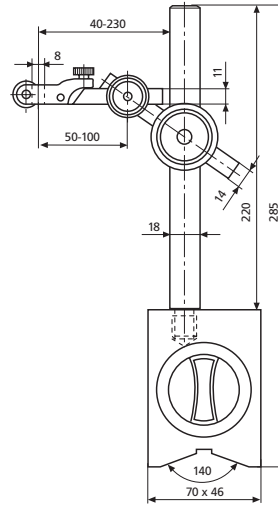

Features

- Support arm with two joints
- Base has a powerful ON/OFF permanent magnet
- Magnetic force is active across the surfaces and the V-shaped bottom plus the front of the base
- Post and support arm are made from stainless steel
- Support arm can be finely adjusted

Technical Data

Total height with base		V-way for shaft dia.	Magnetic force	Fine adjustment range	Weight	Order no.* Mount dia.	Order no.* Mount dia.	Order no. wooden case
mm	inch	mm	N	mm	kg	8H7	3/8"	
285	11.2"	20 - 100	450	2	2.5	4416000	4416050	4416001

* excludes indicating instrument

Indicator Stand 815 MB with magnetic base

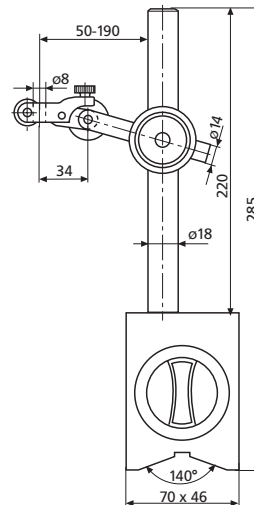

Features

- Support arm with one joint
- Base has a powerful ON/OFF permanent magnet
- Magnetic force is active across the surfaces and the V-shaped bottom plus the front of the base
- Post and support arm are made from stainless steel
- Support arm can be finely adjusted
- Indicating instrument can be rotated through $\pm 90^\circ$

Technical Data

Total height with base		V-way for shaft dia.	Magnetic force	Fine adjustment range	Weight	Order no.* Mount dia.	Order no.* Mount dia.	Order no. wooden case
mm	inch	mm	N	mm	kg	8H7	3/8"	
285	11.2"	20 - 100	450	2	2.2	4417000	4417050	4416001

* excludes indicating instrument

Indicator Stand 815 MG with flexible stem

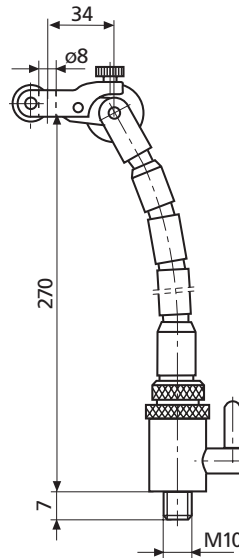

Features

- Flexible in any direction, arm can be locked in position
- The sleeves and grounded steel balls of the stem are compressed with a strong steel cable
- Clamping force is adjustable
- Base has a powerful ON/OFF permanent magnet
- Magnetic force is active across the surfaces and the V-shaped bottom plus the front of the base
- Support arm can be finely adjusted
- Indicating instrument can be rotated through $\pm 90^\circ$

Technical Data

Total height with base		V-way for shaft dia.	Magnetic force	Fine adjustment range	Weight	Order no.* Mount dia.	Order no.* Mount dia.	Order no. wooden case.
mm	inch	mm	N	mm	kg	8H7	3/8"	
350	14"	20 - 100	450	1.5	1.9	4420000	4420001	4416001

* excludes indicating instrument

Indicator Stand 815 P with magnetic base

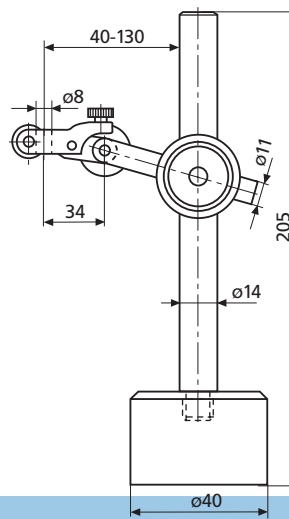

Features

- Support arm has one joint
- Sturdy circular base with permanent magnet
- Post and support arm are made from stainless steel
- Support arm can be finely adjusted
- Indicating instrument can be rotated through $\pm 90^\circ$

Technical Data

Total height with base		Magnetic force	Fine adjustment range	Weight	Order no.* Mount dia.	Order no.* Mount dia.
mm	inch	N	mm	kg	8H7	3/8"
205	8"	250	1.5	0.7	4422000	4422050

* excludes indicating instrument

Post and Support Assemblies 815 X

For application in inspection equipment for conducting length and concentricity (run-out) tests

815 XN

for mounting in a T-slot

- Two joints
- Knurled nut for clamping to the post
- Post and support arm are made from stainless steel
- With fine adjustment

Order no. 4424000

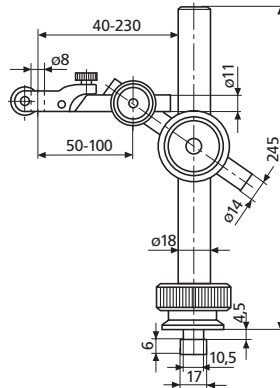

815 XMA

with mounting thread

- Two joints
- Post and support arm are made from stainless steel
- With fine adjustment

Order no. 4424005

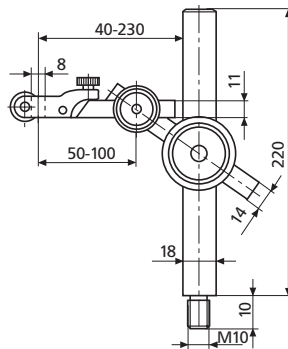

815 XMB

with mounting thread

- One joint
- Post and support arm are made from stainless steel
- With fine adjustment

Order no. 4424006

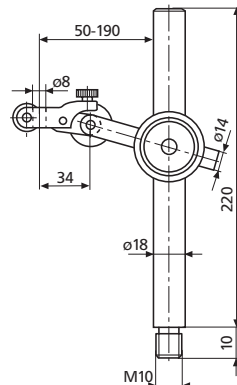

815 XMS

especially stable version with mounting thread

- One joint
- Post and support arm are made from stainless steel
- With fine adjustment

Post height Order no.

285 mm **4435011**
485 mm **4435015**

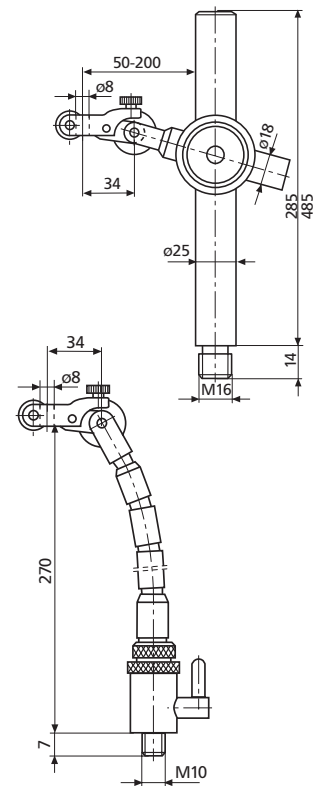

815 XMG

with mounting thread

- Flexible in any direction, arm can be locked in position
- With fine adjustment

Order no. 4424010

815 XP

with mounting thread

- One joint
- Post and support arm are made from stainless steel
- With fine adjustment

Order no. 4424015

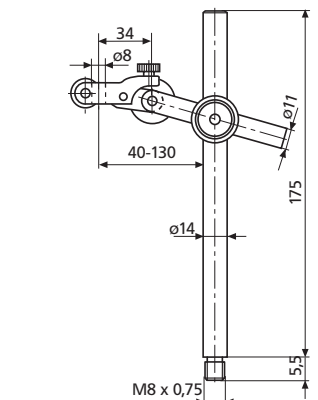

Magnetic Bases 815 Y

For the setting up of inspection equipment or as a base for adjusting devices on machine tools.

815 YM Standard Version

- Base has a powerful ON/OFF permanent magnet
- With threaded mounting hole
- V-groove in base
- Front is flat
- Magnetic force 450 N

Order no. 4425000

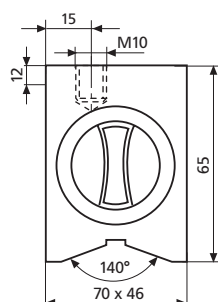

815 YP Round Version

- Permanent magnet plus threaded mounting hole
- Underside of the base is flat
- Magnetic force 250 N

Order no. 4425002

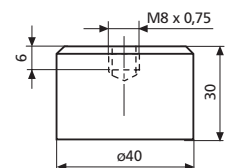

Center Bench 818



Features

- Ideal for quick and accurate concentricity / run-out checks

Bench:

- Flatness of the surface is in accordance to DIN 876/1
- Two T-slots for Tailstock and / or Support Arm

Tailstock:

- Both Tailstocks can be relocated (slide into position)
- The Tailstock on the right side has a retractable (spring actuated) precision aligned center
- The Tailstocks have a peak height of 75 mm with a 90° prism for workpieces without a center, to a diameter of 20 mm (0.79")

Support Arm 818 XNB:

- Support arm with one joint
- with fine adjustment

Technical Data

Height of centers mm	Height of centers (inch)	Distance between centers mm	Distance between centers (inch)	Base size (L x W) mm	Lateral and/or height difference of Tailstocks mm	T-slot width mm	Weight kg	Order no.*
50	(2")	0 - 200	(0-8")	350 x 110	0.01	10H7	8	4622200
75	(3")	0 - 350	(0-14")	500 x 110	0.01	10H7	12	4622201
100	(4")	0 - 450	(0-18")	700 x 180	0.01	12H7	35	4622202
150	(6")	0 - 450	(0-18")	700 x 180	0.01	12H7	38	4622203

* excludes indicating instrument

Center Bench 818 with V-support

V-support height mm	Base size (L x W) mm	T-slot width mm	Weight kg	Order n. (excludes indicating instrument)
70	350 x 110	10H7	6,5	4622260
70	500 x 110	10H7	9,5	4622261
120	700 x 180	12H7	30	4622262

Center Bench 818 with Roller support

Roller support height mm	Base size (L x W) mm	T-slot width mm	Weight kg	Bestell-Nr. (excludes indicating instrument)
70	350 x 110	10H7	6,5	4622250
70	500 x 110	10H7	9,5	4622251
120	700 x 180	12H7	30	4622252

Modular Units 818 for individual center benches

Accessories

818 pe V-support anvils in pairs

Center height mm	Dia. range mm	Order no.
50 / 75	3 - 15	4622210
100	8 - 45	4622211

818 pb V-support in pairs

Height mm	Dia. range mm	T-slot width mm	Order no.
70	5 - 20	10	4622215
120	5 - 45	12	4622216

818 ab Roller support in pairs

Height mm	Dia. range mm	T-slot width mm	Order no.
70	3 - 20	10	4622220
120	3 - 45	12	4622221

Supporting table

Center height mm	Base size (L x W) mm	Order no.
50	350 x 110	4622265
75	500 x 110	4622266
100 / 150	700 x 180	4622267

Pointed support in pairs

Center height mm	Order no.
50	4622270
75	4622271
100	4622272
150	4622273

Support arm 818 XNB

Center height mm	Support Arm Dia. mm	Length mm	Order no.
50 / 75	18	210	4622275
100	18	260	4622276
150	18	360	4622277

818 pe



818 ab

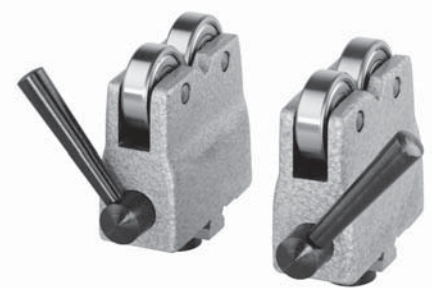

818 pb

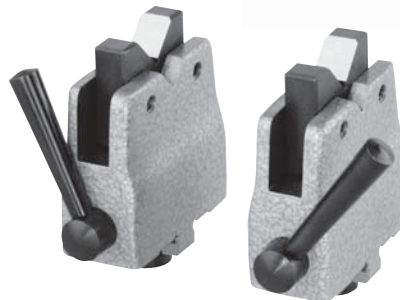

Small Comparator Stands 820

820 N



Indicating instruments are sold separately

Features

- Sturdy design
- Plate is made from either hardened steel or black granite or ceramic
- Rugged ground post made of stainless steel
- Fine adjustment, consisting of a strong, rigid parallel spring assembly (Small Comparator Stands 820 FG and 820 FC)
- Adjustable support arm for a indicating instrument

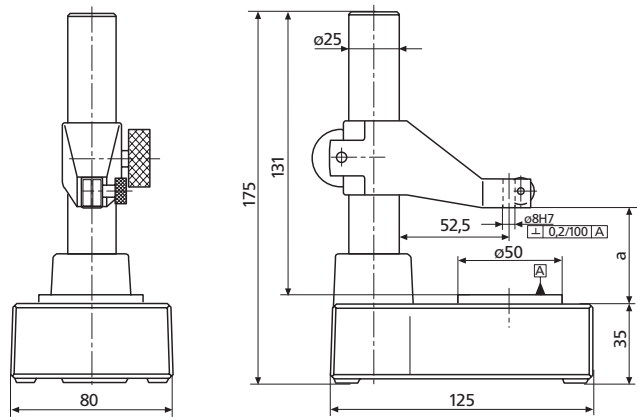

820 N

Technical Data

	Working range a		Flatness tolerance (DIN 876)	Fine adjustment range	Weight	Order no.* Mount dia. 8H7	Order no.* Mount dia. 3/8 inch	Remarks
	mm	(inch)	mm		kg			
820 N	0 - 110	(0 - 4.3")	steel	00	2.6	4430000	4430018	
820 NG	0 - 130	(0 - 5.1")	granite	0	3.2	4430100	4430110	
820 FG	0 - 130	(0 - 5.1")	granite	± 0.2	3.2	4431100	4431110	fine adjustment
820 NC	0 - 110	(0 - 4.3")	ceramic	00	4.0	4432100	4432120	
820 FC	0 - 110	(0 - 4.3")	ceramic	± 0.2	4.0	4433100	4433110	fine adjustment

* excludes indicating instrument

Small Comparator Stands 820

820 FC



820 FG



820 FC

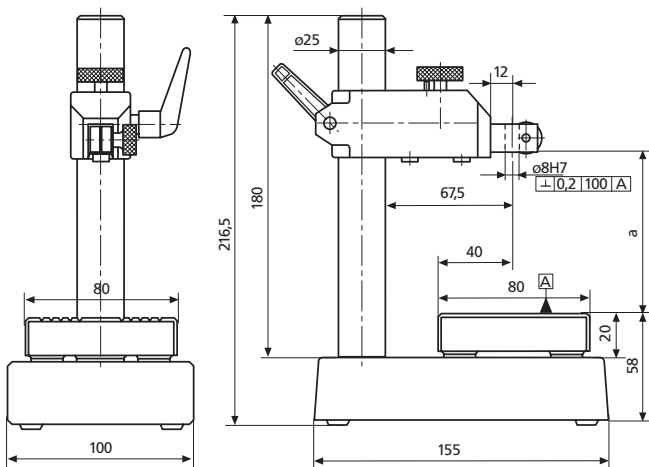

820 FG

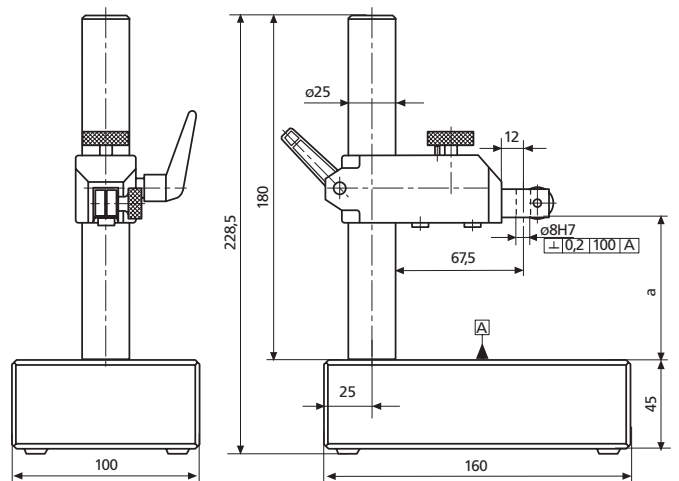

Accessories

V-Block 108° for checking small, cylindrical work pieces for out of roundness and polygon errors (for further details please refer to Page 12-9)

107 V

(Single)
(Pair)

Order no.

4229000
4229001

Comparator Stands 35 B



Features

- Model 35B has a precision ground base. Indicator arms with and without fine adjustment are available. Models are also available with lapped anvils for the highest precision work.
- Alternate post lengths, Indicators, Anvils and special fixturing available upon request. Contact Mahr Federal Technical Assistance

Excludes indicating instrument. Only indicating instruments that have a horizontal lug back can be used.

Technical Data

Capacity	Post Diameter	Throat Depth	Reference Surface	Gaging Arm	Anvil	Order no. (w/o indicator)
0 - 8.75" 0 - 222 mm	1.25" 31.75 mm	2.5" 62.5 mm	1 x 3" 25 x 75 mm	adjustable AM-146 plain AM-3 adjustable AM-146 adjustable AM-146	plain none none serrated	OMI-35B-21 OMI-35B-30 OMI-35B-32 OMI-35B-41

Accessories

Replacement Anvils

- Anvils for Comparator Stands 35B-21 and 35B-41 are available: Surface is lapped flat to within .00001"

Type	Dimensions	Order no.
plain surface	25 x 25 x 75 mm (1 x 1 x 3")	AL-96
serrated surface	25 x 25 x 75 mm (1 x 1 x 3")	AL-97

Fine Adjustment Arm

- The Fine Adjust Arm is available separately to convert 35B Comparator Stands with plain arms

Range	Order no.
1.5 mm / 0.060"	AM-146

Readout Specification: Because of the versatility of the Series 35B and NB-60 Stands, almost any type of readout can be used.

- With Dial or Digital Indicators having a horizontal lug back

Comparator Stand NB-60



Excludes indicating instrument. Only indicating instruments that have a horizontal lug back can be used.

Features

- Model NB-60 and NB-61 have the largest base and greatest throat depth. Indicator arms with and without fine adjust are available. Base has a pattern of 1/4-20 tapped holes for mounting platens or special tooling

Technical Data

Capacity	Post Diameter	Throat Depth	Reference Surface	Gaging Arm	Anvil	Order no. (w/o indicator)
0 - 8"	1.25"	4.88"	9.38 x 6.5"	plain AM-10011	none	OMI-NB-60
0 - 203 mm	31.75 mm	124 mm	238 x 165 mm	adjustable AM-147	none	OMI-NB-61

Accessories

Platens

Type	Dimensions	Order no.
serrated	114 x 152 mm (4.5 x 6")	PL-99
serrated	152 x 203 mm (6 x 8")	PL-147

Note: (4) screws SW-1338 are required

Fine Adjustment Arm

- The Fine Adjust Arm is available separately to convert NB-60 Comparator Stands with plain arms

Range	Order no.
1.5 mm / 0.060"	AM-147

Readout Specification: Because of the versatility of the Series 35B and NB-60 Stands, almost any type of readout can be used.

- With Air Probes or Electronic Probes having a 3/8 in dia., order Mounting Adapter **AAD-66**

Large Comparator Stands 821



Features

- Extremely sturdy design
- Plate is made from lapped black granite
- Heavy duty post and adjustable support arm for maximum stability
- Post made from stainless steel and precision ground
- Support arm has a fall brake
- Fine adjustment, consisting of a strong, rigid parallel spring assembly (Large Comparator Stand 821FG)

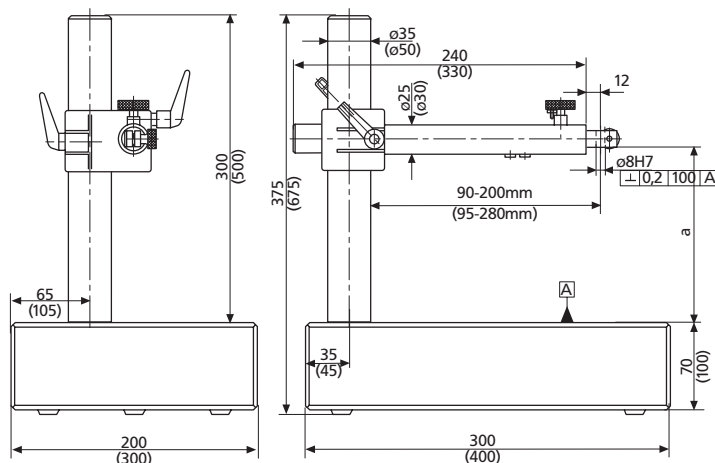

821 FG

Technical Data

	Working range a		Flatness tolerance (DIN 876) Grade	Fine adjustment range mm	Weight kg	Order no.* Mount dia. 8H7	Order no.* Mount dia. 3/8 inch	Remarks
	mm	(inch)						
821 NG	0 - 250	(0 - 10")	0	-	15.8	4435100	4435150	
	0 - 430	(0 - 17")	0	-	48	4435110	4435160	
821 FG	0 - 250	(0 - 10")	0	± 0.2	15.8	4435101	4435151	Fine adjustment
	0 - 430	(0 - 17")	0	± 0.2	48	4435111	4435161	

* excludes indicating instrument

Accessories

V-Block 108° for checking small, cylindrical work pieces for out of roundness and polygon errors (for further details please refer to Page 12-9)

	Order no.
107 V	(Single) 4229000 (Pair) 4229001

Heavy Comparator Stands 824



Precision Stand 824 NT

Without fine adjustment



Precision Stand 824 FT

With fine adjustment, consisting of a strong, rigid parallel spring assembly



Precision Stand 824 GT

For Large Type Millimes. With fine adjustment by way of vertical movement of the mounting socket

Features

Basic Units

- Sturdy, T-shaped base which is made from a special cast iron
- Extremely stable
- Fine adjustment, consisting of a strong, rigid parallel spring assembly
- Support arm has a rotation lock, height of the arm via the toothed rack is adjustable

Plates

- Measuring faces are hardened and lapped
- Longitudinal grooves
- Plates for sum measurements have a 8H7 mm mounting hole for Inductive Probes

Technical Data

Basic Unit

	Working range		Fine adjustment range	Weight	Order no.*	Order no.*	Order no.*
	mm	(inch)					
824 NT	0 - 210	(0 - 8.2")	-	17	4442100		4442105
824 FT	0 - 210	(0 - 8.2")	± 0.2	19	4443100		4443105
824 GT	0 - 200	(0 - 8.0")	± 1.5	18		4444200	

* excludes indicating instrument, excludes plate

Plates

	Plate size	Flatness tolerance	Mounting hole	Weight	Order no.	Remarks
	mm	µm	mm	kg		
827 b 31	100 x 40	1		1.2	4082731	for single measurement
827 b 32	100 x 40	1	8H7	1.0	4082732	for sum measurement
827 b 33	130 x 130	1		2.5	4082733	for single measurement
827 b 34	130 x 130	1	8H7	2.5	4082734	for sum measurement

Accessories

V-Block 108° for checking small, cylindrical work pieces for out of roundness and polygon errors (for further details please refer to Page 12-9)

	Order no.
107 V	(Single) 4229000 (Pair) 4229001

Modular Units 827 for individual comparator stands

For the combination of comparator stands for special tasks, to adapt existing stands as well as the incorporation into inspection equipment for all types of length measurements.

Base with Post

827 b 5

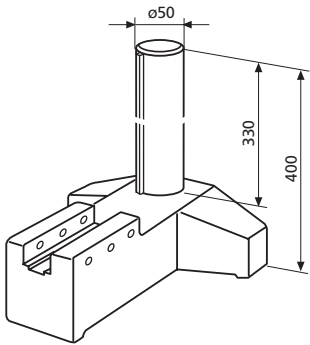

- T-shaped base which is made from a special cast iron
- Post has a chrome finish

Order no. 4082705

Support Arms

827 b 16

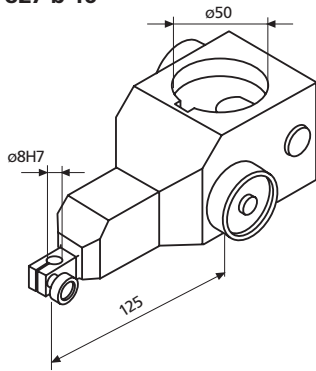

- Mounting hole 8 mm
- Without fine adjustment

Order no. 4082716

827 b 17

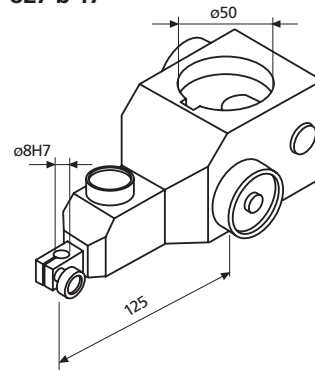

- Mounting hole 8 mm
- Fine adjustment, consisting of a strong, rigid parallel spring assembly

Order no. 4082717

827 b 18

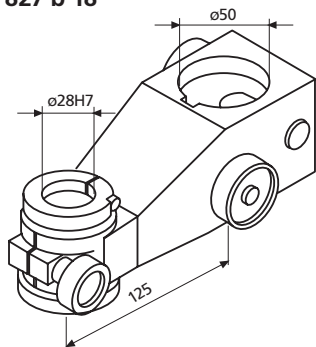

- Mounting hole 28 mm
- With fine adjustment

Order no. 4082718

827 b 19

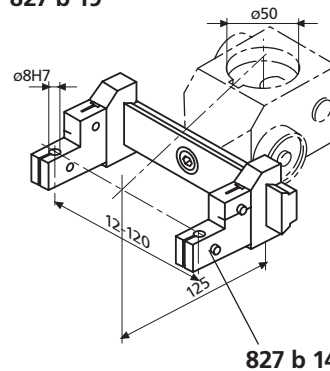

- Support arm with dovetail guide

Order no. 4082719

827 b 14

- With probe holder, mounting hole 8 mm

Order no. 4082714

Modular Units 827 for individual comparator stands

Plates

827 b 31

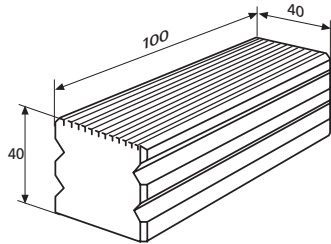

- For single measurement
- Hardened and lapped
- Reversible
- Measuring surface has longitudinal grooves
- Flatness deviation 1 μm

Order no. 4082731

827 b 32

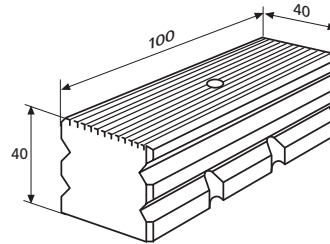

- For sum measurement
- Measuring surface has longitudinal grooves, hardened and lapped
- With mounting hole 8H7 mm/ .375" and a clamp for inductive probes
- Flatness deviation 1 μm

Order no. 4082732

827 b 33

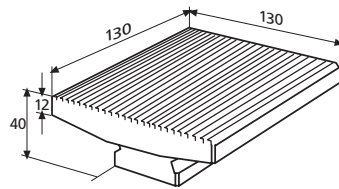

- For single measurement
- Large measuring surfaces which has longitudinal grooves, hardened and lapped
- Flatness deviation 1 μm

Order no. 4082733

827 b 34

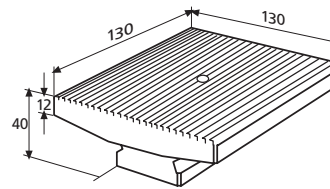

- For sum measurement
- Large measuring surfaces which have longitudinal grooves, hardened and lapped
- With mounting hole 8H7 mm/ .375" and a clamp for inductive probes
- Flatness deviation 1 μm

Order no. 4082734

Adjustable Stop

827 b 35

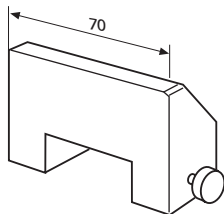

- Ensures that a work piece is correctly positioned
- To be attached to plates 827 b 31 and 827 b 32

Order no. 4082735

Attachment Stand

827 b 36

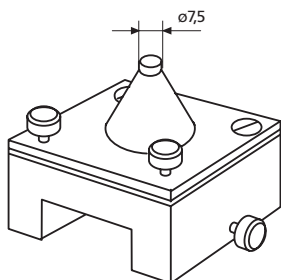

- With adjustment screws for parallel alignment of 2 plan surfaces
- Particularly suitable for mounting Pin Gages 426 M
- To be attached to plates 827 b 31 and 827 b 32

Order . 4082736

THE BENCHMARK OF INDICATING MEASURING INSTRUMENTS. **MARAMETER.**



The latest information on MARAMETER products can be found on our website:

www.mahr.com, WebCode 211

► | Marameter is the ideal measuring instrument for highly precise measurements of internal and external diameters on either an individual part or on serial components. Our indicating measuring instruments obtain the best results due to their constant measuring force, their exact transmission lever system as well as their high parallelism on the measuring faces. For special measuring tasks such as threads, teeth, grooves or precision mechanical parts Marameter offers the right solution. | ◀

► | MaraMeter. Indicating Measuring Instruments

Indicating Measuring Instruments for Outside Dimensions, Indicating Snap Gages

**MaraMeter 1000 P / 300 P / 840 F / 840 FC / 840 FH /
840 FG / 840 FM / 840 FS** **9- 2**

With fixed or interchangeable measuring faces

MaraMeter 840 E **9-18**

For extremely high precision

MaraMeter 852 / 852 TS / 853 **9-19**

For threads, pitches, roots, serrations

Portable Thickness Gages

MaraMeter 22 P / 26 P / 838 A / 838 B / 838 AB / 57 B **9-26**

With digital and/or analog display

Caliper Gages

MaraMeter 49 P / 838 TA / 838 EA / 838 TI / 838 EI **9-33**

With digital and/or analog display

Depth Gages

MaraMeter 65 P-40 / 75 P-30 / 837 / 75 P-30 / 75 B-1 **9-39**

Indicating Measuring Instruments for Inside Dimensions,

Dimentron® Plug Inside Diameter Gages **9-43**

Designed for high production I.D. gaging

MaraMeter 844 D **9-47**

Indicating Plug Gage for rapid testing of serial components

MaraMeter 844 K **9-54**

Self-centering Dial Bore Gage

Marameter 1280 P Adjustable Bore Gages **9-59**

Superior accuracy for production and inspection

MaraMeter 844 N **9-62**

Self-centering Dial Bore Gage

MaraMeter 844 Z **9-66**

Dial Bore Gage for internal serrations

MaraMeter. Indicating Snap Gages

OVERVIEW

► | The Indicating Snap Gages **MaraMeter** 840 F / 300 P-1 are ideal for highly accurate and reliable results on cylindrical work pieces with a narrow tolerance. | ◀

MaraMeter 840 F

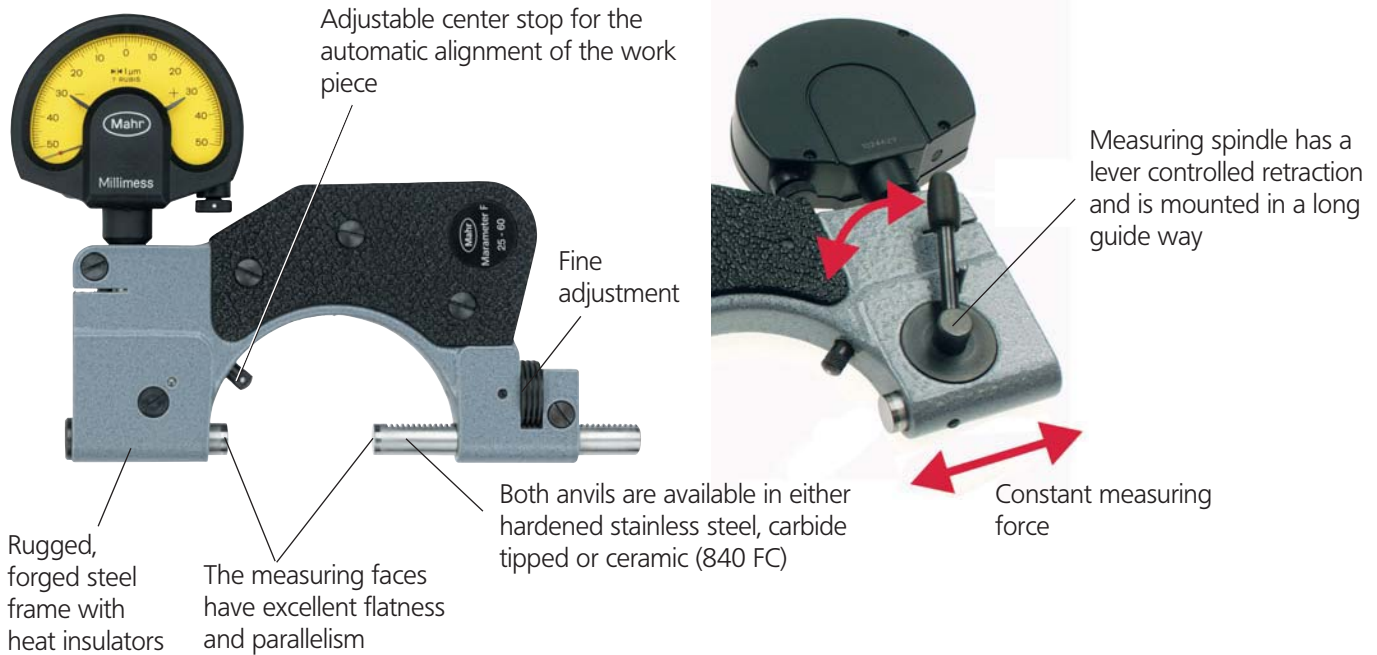

MaraMeter 300 P-1

Indicator can be rotated to read from front or rear of the gage.

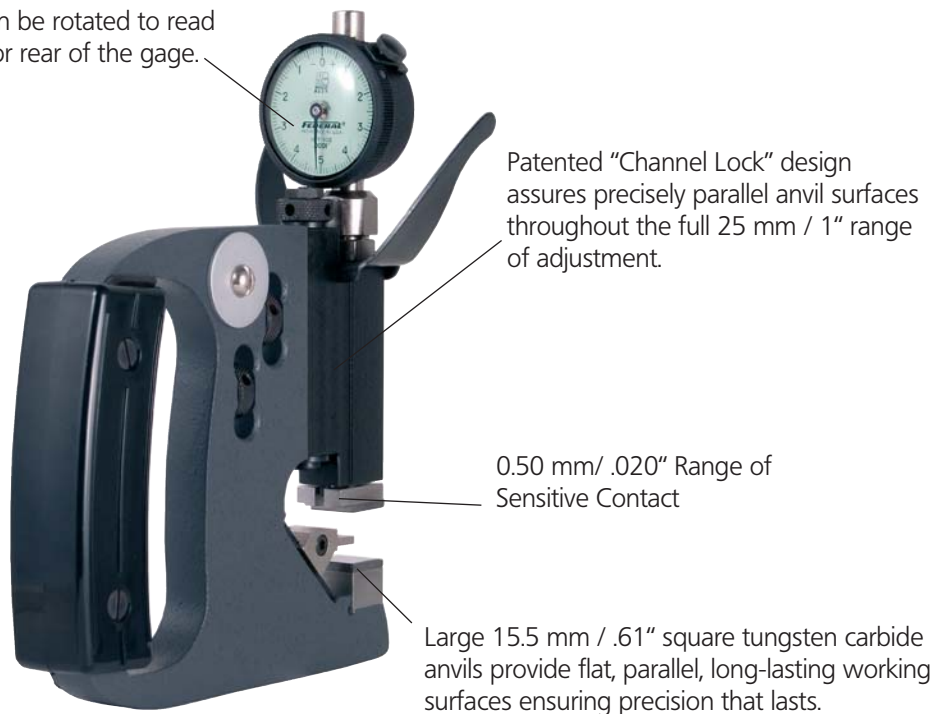

Advantages of the Snap Gage 840 F compared to a Micrometer

• Reduced Measuring Uncertainty

The MaraMeter Indicating Snap Gages have a notably reduced measuring uncertainty in comparison to a Micrometer.

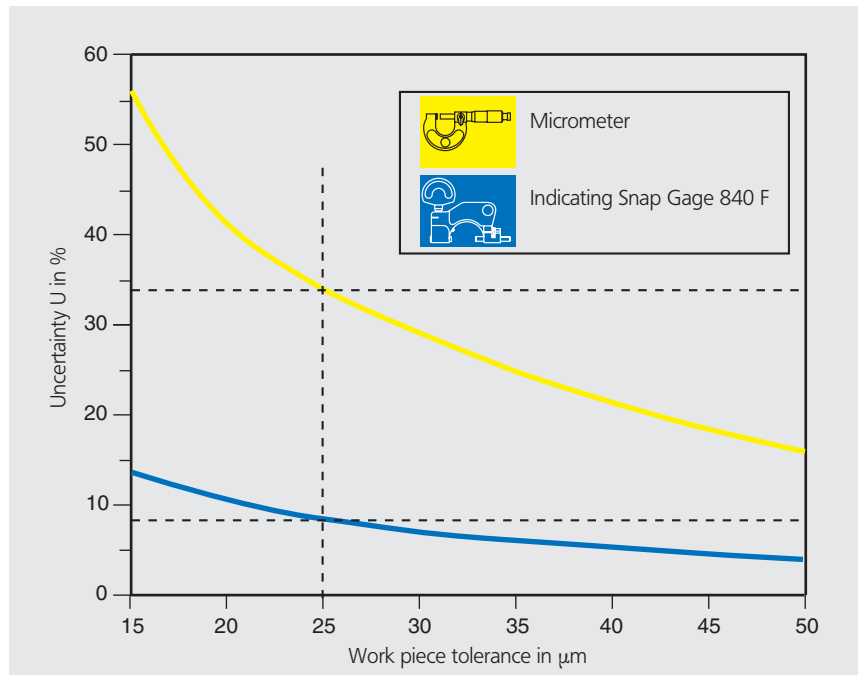

Measuring Uncertainty U is dependent upon the tolerance of the work piece

• Better utilization of the tolerance zone

Example:
Work piece tolerance 25 µm

The measured value in the uncertainty range can lie outside of the tolerance range, therefore the utilized tolerance of the micrometer is reduced to only 32% (8 µm).

With a MaraMeter Indicating Snap Gage 840 F, 83% (20.8 µm) of the work piece tolerance can be utilized.

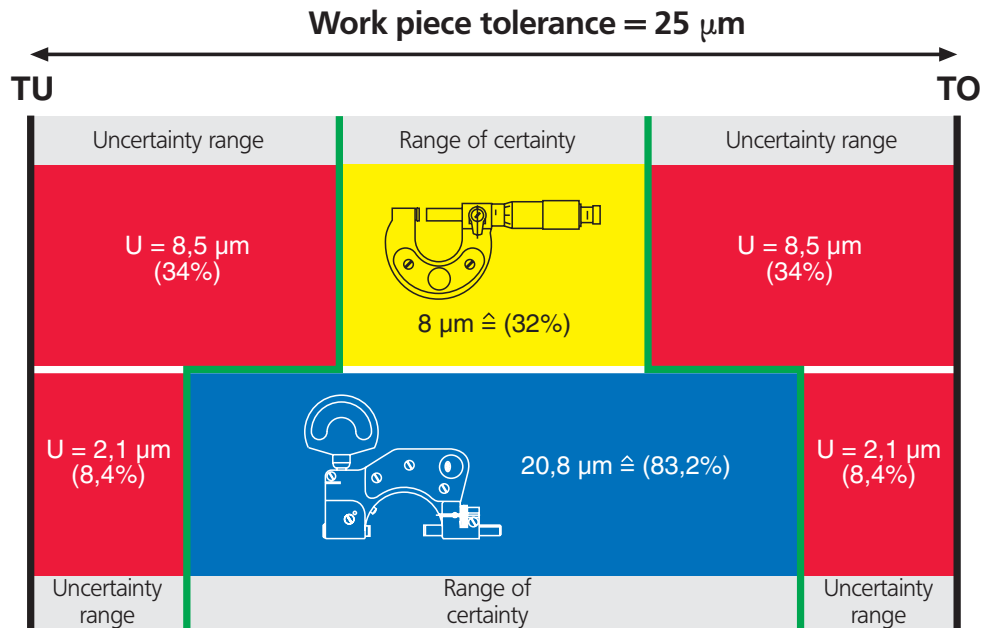

Advantage:

With the Indicating Snap Gage the tolerance zone can be used to far greater extent, thus reducing the production costs.

Snap Gages for Outside Diameters 1000P



The economical way to check outside diameters on the shop floor.

Features

- Flat lower anvil (reference) adjustable over a broad range.
- Radiused upper anvil (sensitive) spring-loaded to counter balance the weight of the gage.
- 0.01 mm grads. on Metric Models. .0005" grads. on Inch Models.
- 0.50 mm / .020" Range of Sensitive Contact.
- Indicator can be rotated to read from front or rear of the gage.
- Anvils are tungsten carbide for long life.

1000P-3

0.01 mm or .0005" Dial Indicator normally furnished

Technical Data

Capacity		Reference Anvil Diameter mm / <i>inch</i>	Order no. Metric	Order no. Inch
mm	(<i>inch</i>)			
0 - 25	(0 - 1")	13 / .50"	1000P-1M*	1000P-1*
19 - 50	(.75 - 2")	13 / .50"	1000P-2M*	1000P-2*
44 - 82	(1.75 - 3.25")	13 / .50"	1000P-3M	1000P-3
76 - 114	(3 - 4.5")	16 / .625"	1000P-4M	1000P-4
102 - 152	(4 - 6")	16 / .625"	1000P-5M	1000P-5
152 - 203	(6 - 8")	19 / .75"	1000P-6M	1000P-6
203 - 254	(8 - 10")	19 / .75"	1000P-7M	1000P-7

Series 1000P gages with greater capacity, alternate Indicators, alternate contact configurations, or other modification to suit specific applications are available – contact Mahr Federal.

* Insulated grip not available.

Snap Gages for Outside Diameters 300P

Superior precision for O.D. checks



EDI-301P-1
BA-26 Bench Stand (not included)

Features

- Patented "Channel Lock" design assures precisely parallel anvil surfaces throughout the full 25 mm / 1" range of adjustment.
- All Series 300P Snap Gages are fully adjustable with positive position locking at any point within the range.
- 0.50 mm / .020" Range of Sensitive Contact.
- Snap Gages available over a wide range of sizes, styles, and readout configurations.
- Large 15.5 mm / .61" square tungsten carbide anvils provide flat, parallel, long lasting working surfaces ensuring precision that lasts.
- Indicator can be rotated to read from front or rear of the gage.
- Optional lift-lever model (301P) available for retracting the upper anvil.
- All adjustments accomplished using a single hex wrench (furnished).

Technical Data

Style	Normally Furnished Indicating Instruments Readings	Snap Style	Separately, Order no.
12I/22I	.0001"	Flat Anvil	IDT-102/IDT-106
O1I/P1I	0.002 mm	Flat Anvil	IDS-206/IDS-208
Maxum [®] /// (1)	selectable (3)	Flat Anvil	2033109
Maxum [®] /// (2)	selectable (3)	Flat Anvil	2033119
EDI-20102	0.0005 mm / .00002"	Flat Anvil	EDI-20102
B5M/C5M	.0005"	Groove Anvil	IDS-101/IDS-105
O6I/P6I	0.010 mm	Groove Anvil	IDS-207/IDS-209
Maxum [®] /// (1)	selectable (3)	Groove Anvil	2033109
Maxum [®] /// (2)	selectable (3)	Groove Anvil	2033119
with Air Probe for 2500:1		All	*
with Electronic Gage Heads		All	*



A300P-2

* Call Mahr Federal.

(1) With no Data Output

(2) With Data Output (6 pin)

(3) Selectable Readings — 0.001 mm / 0.005 mm / 0.0005 mm / .0001" / .0005" / .00002"

Snap Gages for Outside Diameters 300P

Technical Data

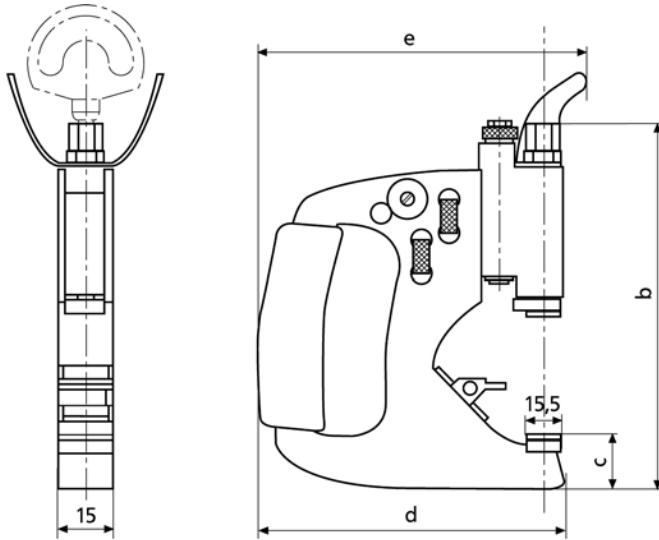

Dimensions

Meas. range mm / inch	b	c	d	e
0 - 25.4 / 0-1"	150/ 6"	29/ 1.16"	145/ 5.8"	158/ 6.3"
25.4 - 50.8 / 1-2"	175/ 7"	29/ 1.16"	141/ 5.6"	154/ 6.16"
50.8 - 76.2 / 2-3"	200/ 8"	29/ 1.16"	155/ 6.2"	167/ 6.7"
76.2 - 101.6 / 3-4"	226/ 9"	29/ 1.16"	167/ 6.7"	180/ 7.2"
101.6 - 127 / 4-5"	251/ 10"	29/ 1.16"	180/ 7.2"	193/ 7.7"
127 - 152.4 / 5-6"	278/ 11"	30/ 1.2"	203/ 8"	215/ 8.6"
152.4 - 177.8 / 6-7"	303/ 12"	30/ 1.2"	213/ 8.5"	226/ 9"
177.8 - 203.2 / 7-8"	329/ 13"	30/ 1.2"	231/ 9.2"	244/ 9.7"
203.2 - 228.6 / 8-9"	335/ 13.5"	30/ 1.2"	248/ 9.9"	261/ 10.4"

Ordering Information

Plain Anvils (Anvils included in price – choose from list below)

Capacity mm/inch	No Indicator	No Indicator with 8 mm adaptor	With Maxµm [®] /// indicator	With Maxµm indicator	With AirProbe [®]	No Indicator with 8 mm adaptor & lift lever	With Dial Indicator No lift lever	With lift lever
0 - 25.4 / 0-1"	OMI-300P-1	2003100	EMD-300P-1	EDI-300P-1	A300P-1	2003110	300P-1	301P-1
25.4 - 50.8 / 1-2"	OMI-300P-2	2003101	EMD-300P-2	EDI-300P-2	A300P-2	2003111	300P-2	301P-2
50.8 - 76.2 / 2-3"	OMI-300P-3	2003102	EMD-300P-3	EDI-300P-3	A300P-3	2003112	300P-3	301P-3
76.2 - 101.6 / 3-4"	OMI-300P-4	2003103	EMD-300P-4	EDI-300P-4	A300P-4	2003113	300P-4	301P-4
101.6 - 127 / 4-5"	OMI-300P-5	2003104	EMD-300P-5	EDI-300P-5	A300P-5	2003114	300P-5	301P-5
127 - 152.4 / 5-6"	OMI-300P-6	2003105	EMD-300P-6	EDI-300P-6	A300P-6	2003115	300P-6	301P-6
152.4 - 177.8 / 6-7"	OMI-300P-7	2003106	EMD-300P-7	EDI-300P-7	A300P-7	2003116	300P-7	301P-7
177.8 - 203.2 / 7-8"	OMI-300P-8	2003107	EMD-300P-8	EDI-300P-8	A300P-8	2003117	300P-8	301P-8
203.2 - 229 / 8-9"	OMI-300P-9	2003108	EMD-300P-9	EDI-300P-9	A300P-9	2003118	300P-9	301P-9

Blade Anvils (Anvils included in price – choose from list below)

0 - 25.4 / 0-1"	OMI-300P-31		EMD-300P-31	EDI-300P-31	A300P-31		300P-31	301P-31
25.4 - 50.8 / 1-2"	OMI-300P-32		EMD-300P-32	EDI-300P-32	A300P-32		300P-32	301P-32
50.8 - 76.2 / 2-3"	OMI-300P-33		EMD-300P-33	EDI-300P-33	A300P-33		300P-33	301P-33
76.2 - 101.6 / 3-4"	OMI-300P-34		EMD-300P-34	EDI-300P-34	A300P-34		300P-34	301P-34
101.6 - 127 / 4-5"	OMI-300P-35		EMD-300P-35	EDI-300P-35	A300P-35		300P-35	301P-35

Larger capacities available on request.

To specify Metric models, add suffix "M" to the Model number. To specify Digital Output, add suffix "D" to Model numbers of EMD-300P and EMD-301P Series Gages. To specify both, add suffix "MD" to Model numbers of EMD-300P and EMD-301P Series Gages.

Examples: 300P-2 specifies a Snap Gage with a 121 (.0001" grad.) Dial Indicator, 25-50 mm / 1-2" capacity.

EMD-301P-33D specifies a Groove Diameter Snap Gage with lift lever, 50-76 mm / 2-3" capacity, AL-110 Blade Anvils, 2033119 (selectable units and resolution) Maxµm/// Indicator with Digital Output

Snap Gages for Outside Diameters 300P

Accessories



BA-71
Bench Stand for Disc Masters



Groove Diameter Snap Gages – One pair of anvil inserts must be specified with each gage. Stocked anvils (shown below) are hardened steel. If no other anvils are specified, AL-110 will be provided.

Anvil Inserts – For all Series 300P-30 and 301P-30 groove gages (2 required per gage).

Order no.

Bench Stand for Gages

Clamps 300P and 1000P Series Gages firmly. A 6.4 mm / 0.25" mounting hole allows permanent fastening to bench surface.

BA-26

Bench Stand for Disc Masters

Holds any AGD style 3 Disc up to 127 mm / 5" diameter and 27 mm / 1.12" wide. Two 6.4 mm / 0.25" mounting holes allow permanent fastening to bench surface

BA-71

Gaging pressure options

For EMD, OMI and Dial Indicator models

Lighter
Heavier

SP-192
SP-118

For EDI models only

Lighter
Heavier

2243295
2243297

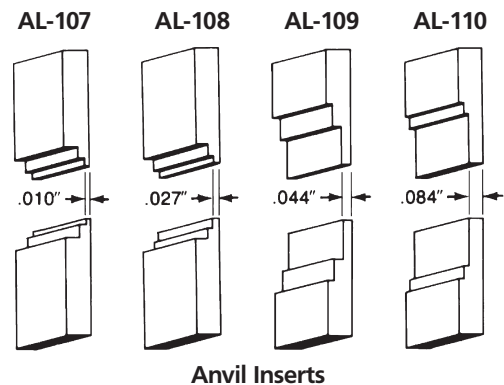

Anvil Inserts

**Plain Anvil Options
Front View**

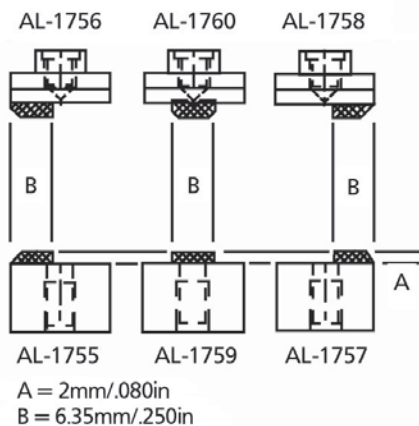

Blade Anvils

Width mm / inch	Depth mm / inch	Order no. Steel	T.C.
0.25 / .010"	0.76 / .030"	AL-107	AL-1741
0.69 / .027"	1.02 / .040"	AL-108	AL-1742
1.12 / .044"	4.83 / .19"	AL-109	AL-1743
2.13 / .084"	6.35 / .25"	AL-110*	AL-1744

* normally provided

Indicating Snap Gages 840 F / 840 FC MaraMeter F



Features

- For cylindrical parts such as shafts, bolts and spindles, for thickness and length measurements
- Rugged, forged steel frame with heat insulators
- Measuring spindle is mounted in long guide way with lever-controlled retraction
- Anvil spindle can easily be fine adjusted
- Measuring spindle and anvil spindle are both made of hardened stainless steel, carbide-tipped or ceramic (840 FC) measuring faces
- Adjustable center stop for automatic alignment
- Maximum wear resistance due to non-contact positioning in conjunction with carbide-tipped measuring faces
- Constant measuring force as a result of built-in spring, thus eliminating user influence
- Universally applicable and extremely versatile. Each instrument spans a broad measuring range, within this range any dimension and fit can be very quickly and easily adjusted
- Supplied with: Steel flat contact points 903

Technical Data

	Measuring range		Repeatability f_w μm	Distance of moveable anvil mm	Measuring force** N	Measuring face		Order no.*	Order no. Wooden case
	mm	(inch)				Flatness μm	Parallelism μm		
840 F	0 - 25	(0 - 1")	≤ 0.5	2	7.5	≤ 0.2	≤ 1	4450000	4450010
	25 - 60	(1 - 2.36")	≤ 0.5	2	7.5	≤ 0.2	≤ 2	4450001	4450011
	50 - 100	(2 - 4")	≤ 1	2.5	7.5	≤ 0.2	≤ 2	4450002	4450012
	100 - 150	(4 - 6")	≤ 1	2.5	7.5	≤ 0.2	≤ 2	4450003	4450013
	150 - 200	(1 - 2.36")	≤ 1	2.5	7.5	≤ 0.2	≤ 2	4450004	4450014
840 FC	0 - 25	(0 - 1")	≤ 1	2	7.5	≤ 0.2	≤ 1	4450100	4450010
	25 - 60	(1 - 2.36")	≤ 1	2	7.5	≤ 0.2	≤ 2	4450101	4450011

* Excludes indicating instrument

** Further measuring forces are available on request

Indicating Instruments

All indicating instruments that has a 8 mm mounting shank may be used. Recommended are:

Dial Comparator		Readings		Order no.	
		mm	/ inch	mm	/ inch
Compress	1004 / 1004 Z	5 μm	/.0001"	4333000 / 4333900	
Millimess	1003 / 1003 Z	1 μm	/.00005"	4334000 / 4334900	
Millimess	1003 XL	2 μm		4334001	
Supramess	1002 / 1002 Z	0.5 μm	/.00002"	4335000 / 4335900	
Extramess	2000	0.2 μm	/.00001"	4346000*	
		0.5 μm	/.00002"		
		1 μm	/.00005"		
Extramess	2001	0.2 μm	/.00001"	4346100*	
		0.5 μm	/.00002"		
		1 μm	/.00005"		
$\mu\text{Max}\mu\text{m}$.0005 mm	/.00002"	EDI-20302*	

Digital Indicators see Chapter 5

Electrical Indicating Instruments see Chapter 7

* 230 V, for 115 V please refer to page 6-5

** requires contact 4360107

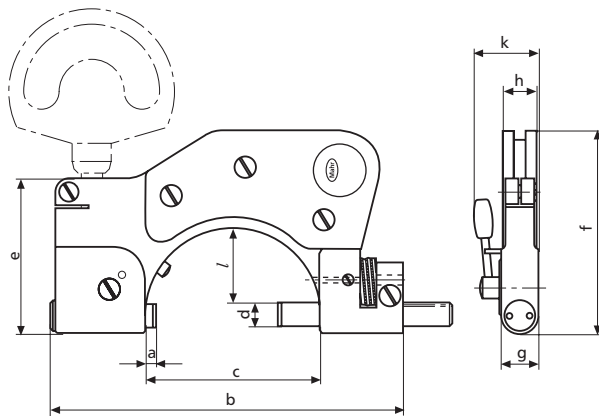

Meas. range	0 - 25	25 - 60	50 - 100	100 - 150	150 - 200
mm					
a*	5	5	6.5	6.5	6.5
b	97	140	193	258	316
c	34	68	110	162	212
d	8	9	10	12	12
e	54	60	60	70	75
f	65	77	103	141	171
g	12	13	14	16	16
h	13	13	13	12	12
k	23	25	28	31	31
l	14	30	54	81	106

* In initial position

Accessories

Reference Discs 390 see Chapter 13

Gage Blocks see Chapter 13

Holder 840 Fk and Stand 840 Ff see Page 9-15

Indicating Snap Gage 840 FH with interchangeable anvils

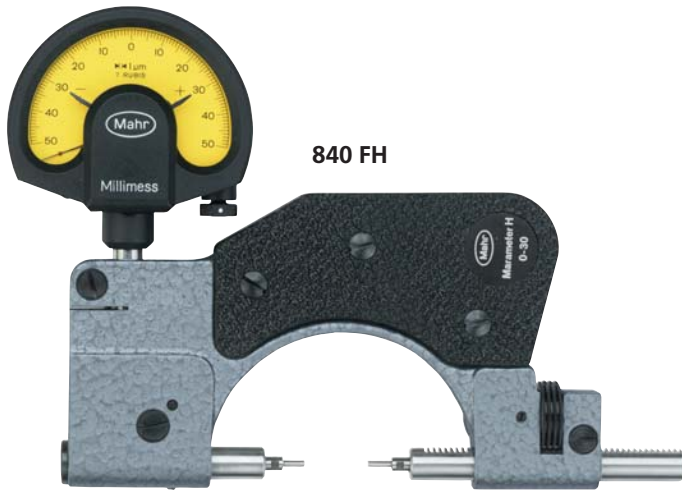

Features

- Measuring spindle and anvil spindle have precision tapered bores for mounting interchangeable anvils 40 He
- For cylindrical parts such as shafts, bolts and spindles
- Rugged, forged steel frame with heat insulators
- Measuring spindle is mounted in long guide way with lever-controlled retraction
- Anvil spindle can easily be fine adjusted
- Measuring spindle and anvil spindle and both made from hardened stainless steel
- Maximum wear resistance due to non-contact positioning
- Constant measuring force as a result of built-in spring, thus eliminating user influence
- Universally applicable
- All kinds of measurement problems can be solved with the broad range of interchangeable anvils
- Supplied with: Steel flat contact points 903, spanner DIN 902-3.5

Technical Data

	Measuring range*		Repeatability $f_w \mu\text{m}$	Distance of moveable anvil mm	Measuring force N	Order no.*	Order no. Wooden case
	mm	(inch)					
840 FH	0 - 30	(0 - 1.18")	≤ 1	2	7.5	4451000	4510010
	30 - 80	(1.18 - 3")	≤ 1	2.5	7.5	4451005	4510011

* Measuring is dependent upon the length of the anvils being used

** Excludes indicating instrument (and anvils)

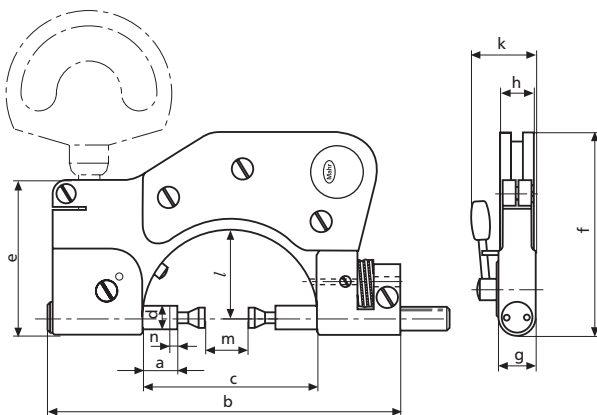

Meas. range 840 FH
m (mm) 0 - 30 30 - 80

a*	12.5	7.5
b	140	193
c	68	110
d	9	10
e	60	60
f	77	103
g	13	13
h	13	13
k	25	28
l	34	59
n**	2	2.5

* In initial position

** Distance of moveable anvil

Indicating Snap Gage 840 FH with interchangeable anvils

with tapered shank

Catalog no.	Features	Order no.
40 He 0H*	Flat faces	4152036
40 He 1	Stepped flat faces	4152011
40 He 1H*	Stepped flat faces	4152033
40 He 2	Stepped flat faces	4152012
40 He 2H*	Stepped flat faces	4152032
40 He 3	Discs	4152013
40 He 4	Discs with V-groove	4152014
40 He 5	Blades	4152015
40 He 6	Offset blades	4152016
40 He 7	Recessed blades	4152017
40 He 8	Recessed flat faces with V-grooves on sleeve	4152018
40 He 9	Recessed flat faces with slip on support	4152019
40 He 10	With clearance bores	4152020
40 He 11	Point	4152021

* Carbide version

Indicating Instruments

All indicating instruments that has a 8 mm mounting shank may be used. Recommended are:

Dial Comparator	Readings mm / inch	Order no. mm / inch
Compramess 1004 / 1004 Z	5 µm/ .0001"	4333000/4333900
Millimess 1003 / 1003 Z	1 µm/ .00005"	4334000/4334900
Millimess 1003 XL	2 µm	4334001
Supramess 1002 / 1002 Z	0.5 µm/ .00002"	4335000/4335900
Extramess 2000	0.2 µm/ .00001"	
	0.5 µm/ .00002"	4346000*
	1 µm/ .00005"	
Extramess 2001	0.2 µm/ .00001"	
	0.5 µm/ .00002"	4346100*
	1 µm/ .00005"	
µMaxµm	.0005 mm/	.00002" EDI-20302*

Digital Indicators see Chapter 5

Electrical Indicating Instruments see Chapter 7

* 230 V, for 115 V please refer to page 6-5 ** requires contact 4360107

Accessories

Spanner (Included in scope of supply) for 840 FH, to loosen anvils

Order no. 4880210

Reference Discs 390 see Chapter 13

Gage Blocks see Chapter 13

Holder 840 Fk and **Stand 840 Ff** see Page 9-15

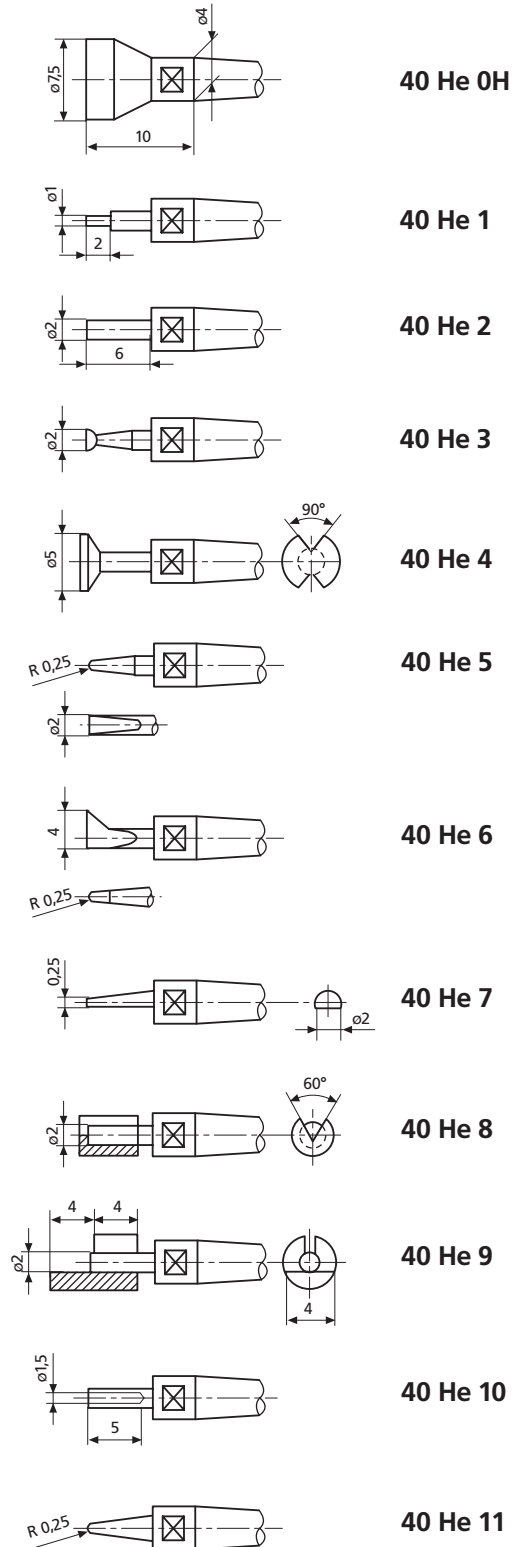

Indicating Snap Gages 840 FG with interchangeable anvils



Features

- Measuring spindle and anvil spindle have a M 2.5 connection thread, thus enabling the use of interchangeable anvils that are also used in dial indicators and dial comparators
- For cylindrical parts such as shafts, bolts and spindles
- Rugged, forged steel frame with heat insulators
- Measuring spindle is mounted in long guide way with lever-controlled retraction
- Anvil spindle can easily be fine adjusted
- Measuring spindle and anvil spindle and both made from hardened stainless steel
- Maximum wear resistance due to non-contact positioning
- Constant measuring force as a result of built-in spring, thus eliminating user influence
- Universally applicable
- All kinds of measurement problems can be solved with the broad range of interchangeable anvils
- Supplied with: Steel flat contact points 903

Technische Daten

	Measuring range*		Repeatability $f_w \mu\text{m}$	Distance of moveable anvil mm	Measuring force N	Order no.*	Order no. Wooden case
	mm	(inch)					
840 FH	0 - 50	(0 - 2")	≤ 0.5	2	7.5	4454000	4510010
	40 - 90	(1.57 - 3.57")	≤ 0.5	2.5	7.5	4454001	4510011

* Measuring is dependent upon the length of the anvils being used

** Excludes indicating instrument (and anvils)

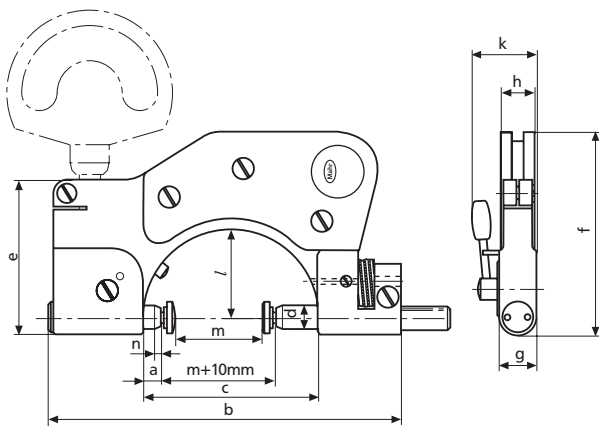

Meas. range 840 FG		
m (mm)	0 - 50	40 - 90
a*	5	6.5
b	140	193
c	68	110
d	9	10
e	60	60
f	77	103
g	13	14
h	13	13
k	25	28
l	34	59
n**	2	2.5

* In initial position

** Distance of moveable anvil

Interchangeable Anvils for Indicating Snap Gage 840 FG

Catalog no.	Features	Order no.
901 H	Standard contact point with carbide ball, ball dia. 3 mm	4360002
902 H	Spherical contact point, with carbide face, R = 6 mm	
	Length <i>l</i> in mm	
	10	4360041
	15	4360043
	20	4360044
903 H*	Flat contact point, carbide tipped	4360101 4360103 4360105 4360106
	Length <i>l</i> in mm	
	6	
	10	
	15	
	20	
904 H	Conical contact point, carbide tipped	4360131

906 H Ball Contact Points					
with carbide ball, manufacturing tolerance ball dia. 0/-6 μm					
Ball dia. d	<i>l</i>	Order no.	Ball dia. d	<i>l</i>	Order no.
mm	mm		mm	mm	
1	8.5	4360150	5.5	9	4360161
1.25	8.5	4360151	6	9	4360162
1.5	8.5	4360152	6.35 (1/4")	9	4360163
1.75	8.5	4360153	6.5	10	4360164
2	8.5	4360154	7	10	4360165
2.5	8.5	4360155	7.5	11	4360166
3	8.5	4360156	8	11	4360167
3.5	8.5	4360157	8.5	12	4360168
4	8.5	4360158	9	12	4360169
4.5	8.5	4360159	10	13	4360170
5	9	4360160			

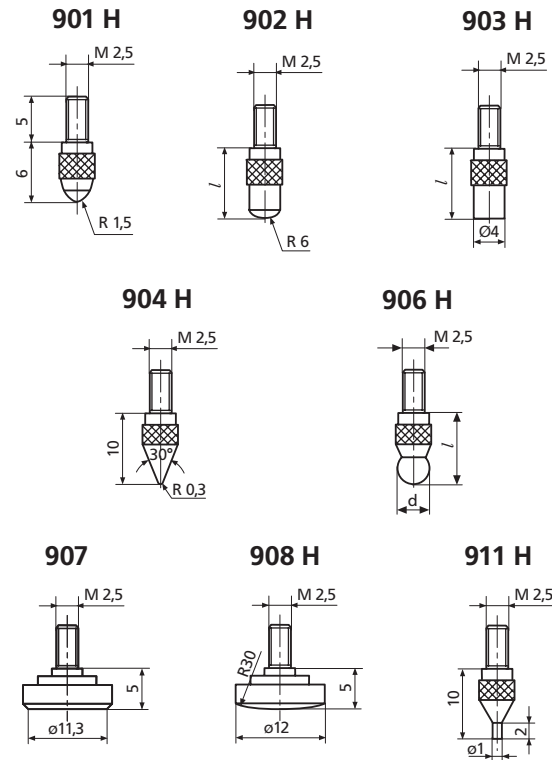

Catalog no.	Features	Order no.
907	Flat contact plates* steel, dia. 11.3 mm, A = 1 cm ²	4360200
907 H	Flat contact plates*, carbide tipped, dia. 7 mm	4360201
908	Spherical contact plates, steel	4360210
908 H	Spherical contact plates, carbide tipped	4360211
911 H	Pin contact point, carbide tipped, dia. 1 mm, plan	4360240

* When using a flat contact plate the opposite facing anvil must be a spherical contact plate.

Indicating Instruments

All indicating instruments that has a 8 mm mounting shank may be used. Recommended are:

Dial Comparator	Readings	Order no.
	mm / inch	mm / inch
Compramess 1004 / 1004 Z	5 μm / .0001"	4333000/4333900
Millimess 1003 / 1003 Z	1 μm / .00005"	4334000/4334900
Millimess 1003 XL	2 μm	4334001
Supramess 1002 / 1002 Z	0.5 μm / .00002"	4335000/4335900
Extramess 2000	0.2 μm / .00001"	
	0.5 μm / .00002"	4346000*
	1 μm / .00005"	
Extramess 2001	0.2 μm / .00001"	
	0.5 μm / .00002"	4346100*
	1 μm / .00005"	
μMax μm	.0005 mm / .00002"	EDI-20302*

Digital Indicators see Chapter 5

Electrical Indicating Instruments see Chapter 7

* 230 V, for 115 V please refer to page 6-5 ** requires contact 4360107

Accessories

Reference Discs 390 see Chapter 13

Gage Blocks see Chapter 13

Holder 840 Fk and Stand 840 Ff see Page 9-15

Indicating Snap Gages 840 FM MaraMeter M with measuring jaws

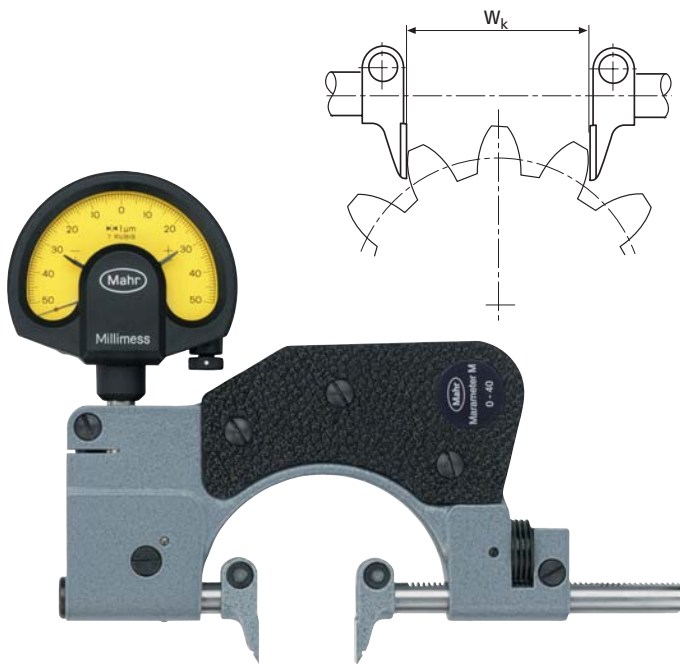

Features

- For diameters of small hubs, registers, shoulders on shafts and groove widths as well as for tooth span W_k as indirect, reference-free determination of tooth thickness on spur gears with straight and helical teeth
- Rugged, forged steel frame with heat insulators
- Measuring spindle is mounted in long guide way with lever-controlled retraction
- Anvil spindle can easily be fine adjusted
- Maximum wear resistance due to non-contact positioning in conjunction with carbide-tipped measuring faces
- Measuring spindle and anvil spindle made of hardened stainless steel; with extending carbide-tipped measuring jaws
- Constant measuring force as a result of built-in spring, thus eliminating user influence
- Universally applicable and extremely versatile, each instrument spans a broad measuring range, within this range any dimension and fit can be very quickly and easily adjusted
- Supplied with: Steel flat contact points 903

Technical Data

	Measuring range		Repeatability f_w μm	Measuring force N	Measuring face			Tooth span measurements as per module m	Order no.*	Order no. Wooden case
	mm	(inch)			Area mm	Flatness μm	Parallelism μm			
840 FM	0 - 40	(0 - 1.57")	1	7.5	12 x 12	≤ 0.5	≤ 2	0.5	4452000	4450011
	40 - 80	(1.57 - 3")	1	7.5	12 x 12	≤ 0.5	≤ 3	0.5	4452001	4450012
	80 - 130	(3 - 5")	1	9	15 x 17	≤ 0.5	≤ 3	1.0	4452002	4450013
	130 - 180	(5 - 7")	1	9	15 x 17	≤ 0.5	≤ 3	1.0	4452003	4450014

* Excludes indicating instrument

Dimensions

Meas. range (mm)	0 - 40	40 - 80	80 - 130	130 - 180
Dist mov. anvil (mm)	2	2.5	2.5	2.5
a*	14	14	19	15
b	140	193	258	316
c	68	110	162	212
e	60	60	70	75
f	77	103	141	171
g	13	14	16	16
h	13	13	12	12
k	25	28	31	31
l	34	59	87	112
m	12	12	17	17
p	12	12	15	15
t	11	11	17	17

* In initial position

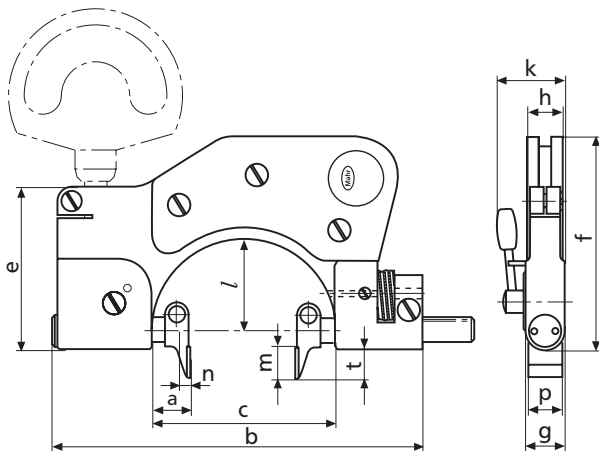

Accessories

Indicating instruments, see Page 9-9
 Reference Discs 390 see Chapter 13
 Gage Blocks see Chapter 13
 Holder 840 Fk and Stand 840 Ff see Page 9-15

Accessories for Dial Indicators and Dial Comparators



Holder 840 Fk for Dial Indicators and Dial Comparators

- For attaching to the following measuring instruments **840 F/FC, 840 FH, 840 FG, 840 FM** and **852**
- Straight transfer of the spindle movement to the indicator
- Following the Abbe principle allows an even higher degree of accuracy than the already excellent level obtained with the standard set-up employing 90° transmission
- When the indicating instrument is in the shown position it is often easier to read
- For stationary application when in conjunction with the **Stand 840 Ff**

Catalog no.	Suitable for instruments with measuring ranges (mm)					Order no.
	840 F/FC	840 FH	840 FG	840 FM	852	
840 Fk/1	0 - 25					4450050
840 Fk/2	25 - 60	0 - 30	0 - 50	0 - 40	0 - 45	4450051
840 Fk/3	50 - 100	30 - 80	40 - 90	40 - 80	45 - 85	4450052
840 Fk/4	{ 100 - 150 150 - 200			{ 80 - 130 130 - 180	{ 85 - 140 140 - 190	4450053



Stand 840 Ff

- For stationary application in conjunction with the following measuring instruments **840 F/FC, 840 FH, 840 FG, 840 FM, 840 E** and **852**
- User has both hands free for insertion of work piece and retraction of moving spindle
- Indicating instrument is always in operator's field of vision
- Rugged, rigid cast-iron stand with clamp for locking the indicating snap gage
- Indicating snap gage is locked in mounting hole for dial comparator
- Only in conjunction with **Holder 840 Fk**

Catalog no.	Suitable for instruments with measuring ranges (mm)						Order no.
	840 F/FC	840 FH	840 FG	840 FM	840 E	852	
840 Ff	{ 0 - 25 25 - 60	0 - 30	0 - 50	0 - 40	0 - 25	0 - 45	4450020

Indicating Snap Gages 840 FS MaraMeter S



Features

- For all kinds of cylindrical work pieces, whether directly on a machine tool or in the production control
- Rigid frame; convenient handle with heat insulators open on one end to eliminate heat transfer from user's hand
- Both spindles are made of hardened stainless steel and mounted in long guide ways
- Carbide-tipped measuring faces slightly chamfered at the front to facilitate positioning
- Projects over width of frame for measurement of narrow registers or when measuring directly at shoulders
- Maximum accuracy. Straight transfer of spindle movement to indicator. During the measurement, the weight of the gage rests on the anvil spindle
- Adjustable center stop for automatic alignment
- Indicating instrument is protected against possible impact during handling by a laterally projecting guard
- Direct indication and evaluation of measurement results
- Universally applicable and extremely versatile, each instrument spans a broad measuring range, within this range any dimension and fit can be very quickly and easily adjusted
- Constant measuring force as a result of built-in spring, thus eliminating user influence
- Supplied with:
Wooden case up to 300 mm, allen key

Technical Data

	Measuring range		Repeatability f_w μm	Measuring force N	Distance of moveable anvil mm	Measuring faces		Weight kg	Order no.*
	mm	(inch)				Flatness μm	Parallelism μm		
840 FS	10 - 30	(.39 - 1.18")	1	13.5	0.7	≤ 0.5	≤ 3	0.6	4455000
840 FS	30 - 60	(1.18 - 2.36")	1	13.5	0.7	≤ 0.5	≤ 3	0.9	4455001
840 FS	60 - 100	(2.36 - 4")	1	13.5	0.7	≤ 0.5	≤ 3	1.3	4455002
840 FS	100 - 150	(4 - 6")	1	15	0.7	≤ 0.5	≤ 3	1.7	4455003
840 FS	150 - 200	(6 - 8")	1	15	0.7	≤ 0.5	≤ 3	2.0	4455004
840 FS	200 - 250	(8 - 10")	1	15	0.7	≤ 0.5	≤ 3	2.2	4455005
840 FS	250 - 300	(10 - 12")	1	15	0.7	≤ 0.5	≤ 3	2.5	4455006
840 FS	300 - 350	(12 - 14")	1	15	0.7	≤ 0.5	≤ 4	3.3	4455007
840 FS	350 - 400	(14 - 16")	1	15	0.7	≤ 0.5	≤ 4	3.3	4455008
840 FS	400 - 450	(16 - 18")	1	15	0.7	≤ 0.5	≤ 4	4.3	4455009
840 FS	450 - 500	(18 - 20")	1	15	0.7	≤ 0.5	≤ 4	4.7	4455010

* Excludes indicating instrument

Technical Data

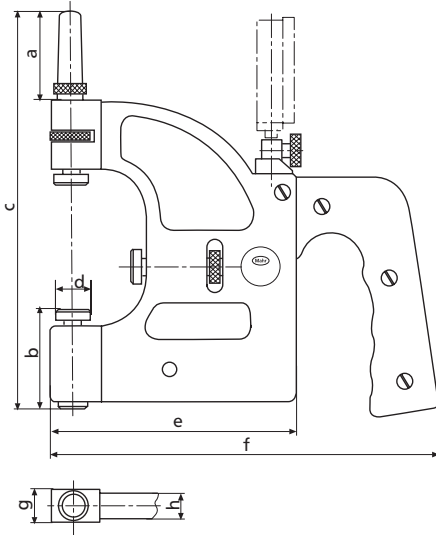

Dimensions

Meas. range mm	dia. d	a	b	c	e	f	g	h
10 - 30	18	37	46	154	87	161	17	15
30 - 60	18	45	51	199	122	196	17	15
60 - 100	22	56	62	260	154	228	20	18
100 - 150	22	71	62	335	189	263	20	18
150 - 200	22	71	62	385	214	288	20	18
200 - 250	22	71	62	436	248	322	20	18
250 - 300	22	71	62	487	280	354	20	18
300 - 350	22	71	62	537	310	384	20	18
350 - 400	22	71	62	587	350	424	20	18
400 - 450	22	71	62	637	380	454	20	18
450 - 500	22	71	62	687	410	484	20	18

Accessories

Indicating Instruments

All indicating instruments that has a 8 mm mounting shank may be used. Recommended are:

Dial Comparator	Readings mm / inch	Order no. mm / inch
Compramess 1004 / 1004 Z	5 µm/ .0001"	4333000/4333900
Millimess 1003 / 1003 Z	1 µm/ .00005"	4334000/4334900
Millimess 1003 XL	2 µm	4334001
Supramess 1002 / 1002 Z	0.5 µm/ .00002"	4335000/4335900
Extramess 2000	0.2 µm/ .00001"	
	0.5 µm/ .00002"	4346000*
	1 µm/ .00005"	
Extramess 2001	0.2 µm/ .00001"	
	0.5 µm/ .00002"	4346100*
	1 µm/ .00005"	
µMaxµm	.0005 mm/ .00002"	EDI-20302*

Digital Indicators see Chapter 5

Electrical Indicating Instruments see Chapter 7

* 230 V, for 115 V please refer to page 6-5 ** requires contact 4360045



2000



1003

Electronic Snap Gage 840 E MaraMeter E for extremely high accuracy



Features

- Inductive measuring system incorporated directly into frame
- Readings selectable down to 0.01 μm
- Rugged, forged steel frame with heat insulators
- Measuring spindle mounted in extra long guideway with lever-controlled retraction
- Anvil spindle can easily be fine adjusted
- Measuring spindle and anvil spindle made of hardened stainless steel; measuring faces carbide-tipped
- Adjustable center stop for automatic alignment
- Extremely accurate due to the straight transfer of spindle movement to the inductive measuring system according to the Abbe principle
- Universally applicable and extremely versatile, each instrument spans a broad measuring range, within this range any dimension and fit can be very quickly and easily adjusted
- Maximum wear resistance due to non-contact positioning in conjunction with carbide-tipped measuring faces
- Constant measuring force as a result of built-in spring, thus eliminating user influence

Technical Data

Measuring range	Readings / Resolution adjustable to*	Measuring force	Meas. faces	Repeatability	Meas. faces	Order no. (without indicating instrument)	Order no. Wooden case
mm	μm	N	dia. mm	f_w μm	Parallelism μm		
0 - 25	0.01	4.5	7.5	≤ 0.1	≤ 0.3	4453000	4453010

* Depending upon which indicating instrument is being used

Accessories

Reference Discs 390 see Chapter 13

Gage Blocks see Chapter 13

Stand 840 Ff see Page 9-15

Recommended indicating instruments:

Electrical indicating instruments; recommended are C 1216M, C 1208M and 1240; please refer to Chapter 7



C 1208M



1240

Indicating Bench Snap Gage 852 TS



Applications

- For rapid measurements of diameters of cylindrical parts (shafts, bolts and shanks)
- For measuring pitch, root and outside diameters of all kinds of external threads as well as serrations
- For thickness and length measurement
- Particularly suited for batch produced parts

Features

- Rugged steel frame, can be inclined up to 45° from the sturdy base
- Measuring spindle and anvil spindle are both made of hardened stainless steel, with mounting bore for insertion of interchangeable anvils
- Anvil spindle can easily be fine adjusted
- Height adjustable stop
- Constant measuring force as a result of built-in spring, thus eliminating user influence
- Universally applicable and extremely versatile, each instrument spans a broad measuring range
- Scope of supply: TC-tipped -anvils dia. D= 3.5 mm, Dial Comparator 1003

Technical Data

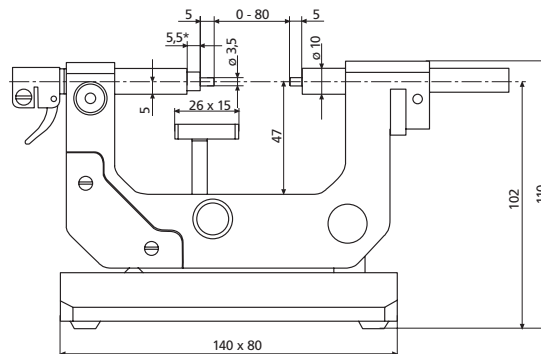

Measuring range**	Repeatability	Retraction	Measuring force	Measuring face	Mounting dia.	Order no.
mm (inch)	f_w μm	mm	N	Parallelism μm		
0 - 80 (0 - 4")	1	1.2	6.5	≤ 2	8 mm 8 mm .375"	4510030*** 4510031 + 4510035 +

* In initial position
+ Excludes indicating instrument, order indicating instrument separately.

** Depending upon which anvils are being used

*** Delivery with a different indicating instrument is available upon request

Accessories

Order no.

Standard TC-tipped anvils,
Pair dia. D= 3.5 mm

4510840

Interchangeable Anvils please refer to Pages 9--22 to 9-24
Thread Setting Plug Gages see Page 13-14

Indicating Thread Snap Gage 852



Features

- For measuring pitch, root and outside diameters of all kinds of external threads as well as serrations
- Rugged, forged steel frame with heat insulators
- Measuring spindle is mounted in long guide way with lever-controlled retraction
- Anvil spindle can easily be fine adjusted
- Measuring spindle and anvil spindle are both made of hardened stainless steel, with mounting bore for insertion of interchangeable anvils
- Adjustable center stop for automatic alignment
- Maximum wear resistance due to non-contact positioning
- Constant measuring force as a result of built-in spring, thus eliminating user influence
- Universally applicable and extremely versatile. each instrument spans a broad measuring range
- Supplied with: Steel flat contact points 903

Technical Data

Measuring range*		Repeatability f_w μm	Measuring force N	Order no.**	Order no. wooden case
mm	(inch)				
0 - 45	(0 - 1.77")	1	7.5	4510000	4510010
45 - 85	(1.77 - 3.34")	1	7.5	4510001	4510011
85 - 140	(3.34 - 5.51")	1	9	4510002	4510012
140 - 190	(5.51 - 7.48")	1	9	4510003	4510013

* Depending upon which anvils are being used, purchase separately

** Excludes indicating instrument and anvils

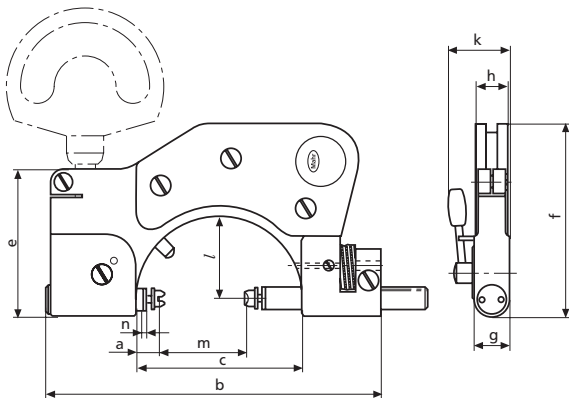

Meas. range m (mm)	0-45	45-85	85-140	140-190
Dist mov. anvil n (mm)	2	2.5	2.5	2.5
a*	13	8	10	6
b	140	193	258	316
c	68	110	162	212
e	60	60	70	75
f	77	103	141	171
g	13	14	16	16
h	13	13	12	12
k	25	28	31	31
l	34	59	87	112

a* = In initial position

Technical Data

Indicating Instruments

All indicating instruments that has a 8 mm mounting shank may be used. Recommended are:

Dial Comparator	Readings mm / inch	Order no. mm / inch
Compramess 1004 / 1004 Z	5 µm/ .0001"	4333000/4333900
Millimess 1003 / 1003 Z	1 µm/ .00005"	4334000/4334900
Millimess 1003 XL	2 µm	4334001
Supramess 1002 / 1002 Z	0.5 µm/ .00002"	4335000/4335900
Extramess 2000	0.2 µm/ .00001"	
	0.5 µm/ .00002"	4346000*
	1 µm/ .00005"	
Extramess 2001	0.2 µm/ .00001"	
	0.5 µm/ .00002"	4346100*
	1 µm/ .00005"	
µMaxµm	.0005 mm/ .00002"	EDI-20302*

Digital Indicators see Chapter 5

Electrical Indicating Instruments see Chapter 7

* 230 V, for 115 V please refer to page 6-5 ** requires contact 4360107



2000



1003

Accessories

Interchangeable Anvils please refer to Pages 9-19

Thread Setting Plug Gages see Page 13-14

Holder 840 Fk and **Stand 840 Ff** (for 0-45 mm) see Page 9-15

Indicating Thread Snap Gage 853 for taps



Features

- For pitch, root and outside diameters on taps in conjunction with interchangeable anvils
- Measuring spindle mounted in long guideway, lever-controlled retraction with mounting bore for interchangeable anvils
- Anvil spindle adjustable with thumbscrew via worm and rack, for mounting interchangeable support yokes
- Measuring spindle and anvil spindle are made of hardened stainless steel
- Further features are similar to the model 852; for details please refer to Page 9-16
- Supplied with: Steel flat contact points 903

Technische Daten

Measuring range		Repeatability f_w μm	Measuring force N	Order no.*	Order no. Wooden case
mm	(inch)				
1.2 - 35	(.04 - 1.37")	2	7.5	4511000	4511020
35 - 75	(1.37 - 3")	2	7.5	4511001	4511021

* Excludes indicating instrument and the support yokes 853 q

Interchangeable Support Yokes 853 q

Depending upon the number of flutes, allowance has to be made for a compensation factor when reading the result. See table below:

Cat. no.	No. of flutes of taps	For meas. range mm	Compens. factor**	Order no.
853 qk 3	3	1.2 - 35	x 1	4511024
853 qk 5	5	1.2 - 35	x 1.34	4511026
853 qk 7	7	1.2 - 35	x 1.42	4511028
853 qg 3	3	35 - 75	x 1	4511025
853 qg 5	5	35 - 75	x 1.34	4511027
853 qg 7	7	35 - 75	x 1.42	4511029

** Allowance is to be made for other compensation methods when using the Holder 840 Fk

Indicating Instruments

All indicating instruments that has a 8 mm mounting shank may be used. Recommended are:

		Readings	Order no.
MarCator	810S	0.001 mm	4311000
Compramess	1004/1004 Z	5 μm / .0001"	4333000/4333900
Zentimess	1010/1010 Z	0.01 mm / .0005"	4332000/4332900
MarCator	1087/1087 Z	1 μm / .00005"	4337060/4337070

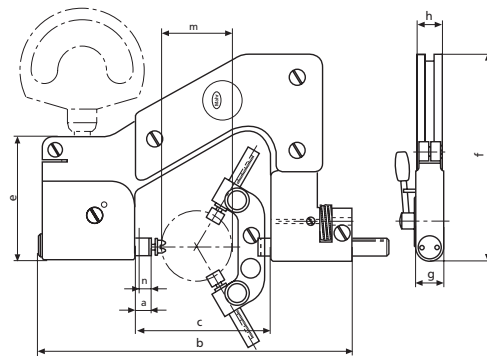

Meas. range m (mm)	1.2-35	35-75
Dist mov. anvil n (mm)	8	8
a*	12	11.5
b	152	192
c	66	110
e	60	65
f	98	125
g	14	14
h	11.5	14

a* = In initial position

Accessories

Dial Comparators see Page 9-1x
 Recommendations: 810 S (see Page 5-32), 1010, 1004
Interchangeable Anvils see from Pages 9-23 to 9-24
Thread Setting Plug Gages see Page 13-20

Interchangeable Anvils for 852, 852 TS and 853

For pitch, root and outside diameters. Special wear-resistant hardened steel. With cylindrical mounting shank and retainer ring which ensures locking while permitting rotation in bore of indicating snap gages.

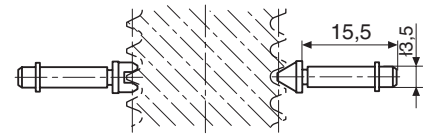

Sets consist of:

For pitch diameters

852 - 1 V-anvil and 1 blade
853 - 1 V-anvil and 2 radiused blades

For root diameters

852 - 1 V-anvil and 1 blade
853 - 1 V-anvil and 2 blades

For outside diameters

852 - 2 flat-face anvils
853 - 3 flat-face anvils

Anvils for pitch diameters for 852 and 852 TS

Pitch mm	Metric thread (60°)		Pitch range tpi	Whitworth thread (55°)		Pitch range tpi	American UST thread (60°)	
	V-anvil Order no.	Blade Order no.		V-anvil Order no.	Blade Order no.		V-anvil Order no.	Blade Order no.
0.2*	4173007	4173707	40 - 32	4173043	4173743	60 - 48	4173113	4173813
0.25*	4173008	4173708	32 - 24	4173044	4173744	48 - 40	4173114	4173814
0.3*	4173009	4173709	24 - 18	4173045	4173745	40 - 32	4173115	4173815
0.35*	4173010	4173710	18 - 14	4173046	4173746	32 - 24	4173116	4173816
0.4*	4173011	4173711	14 - 10	4173047	4173747	24 - 18	4173117	4173817
0.45*	4173012	4173712	10 - 7	4173048	4173748	18 - 14	4173118	4173818
0.5 - 0.7	4173000	4173700	7 - 4.5	4173049	4173749	14 - 10	4173119	4173819
0.7 - 1	4173001	4173701	4.5 - 3	4173050	4173750	10 - 7	4173120	4173820
1.25 - 2	4173002	4173702	3 - 2.5	4179408	4179410	7 - 4.5	4173121	4173821
2 - 3.5	4173003	4173703				4.5 - 3	4173122	4173822
3.5 - 5	4173004	4173704						
5 - 7	4173005	4173705						
7 - 9	4173006	4173706						

Anvils for pitch diameters for Indicating Thread Snap Gage 853

Pitch mm	Metric thread (60°)		Pitch range tpi	Whitworth thread (55°)		Pitch range tpi	American UST thread (60°)	
	V-anvil Order no.	Blade Order no.		V-anvil Order no.	Blade Order no.		V-anvil Order no.	Blade Order no.
0.2	4173051	4174007	40 - 32	4173043	4176043	60 - 48	4173124	4176113
0.25	4173052	4174008	32 - 24	4173044	4176044	48 - 40	4173125	4176114
0.3	4173053	4174009	24 - 18	4173045	4176045	40 - 32	4173115	4176115
0.35	4173054	4174010	18 - 14	4173046	4176046	32 - 24	4173116	4176116
0.4	4173055	4174011	14 - 10	4173047	4176047	24 - 18	4173117	4176117
0.45	4173056	4174012	10 - 7	4173048	4176048	18 - 14	4173118	4176118
0.5 - 0.7	4173000	4174000	7 - 4.5	4173049	4176049	14 - 10	4173119	4176119
0.7 - 1	4173001	4174001	4.5 - 3	4173050	4176050	10 - 7	4173120	4176120
1.25 - 2	4173002	4174002	3 - 2.5	4179408	4179411	7 - 4.5	4173121	4176121
2 - 3.5	4173003	4174003				4.5 - 3	4173122	4176122
3.5 - 5	4173004	4174004						
5 - 7	4173005	4174005						
7 - 9	4173006	4174006						

Carbide anvils for 852, 852TS and 853

1.25 - 2	4511105	4511104
2 - 3.5	4511108	4511107
3.5 - 5	4511140	4511139
5 - 7	4511142	4511141

* V-anvil covers 3 pitches

Interchangeable Anvils for 852, 852 TS and 853

For root diameters

Each pitch requires a separate V-anvil.
Blade can be used for several pitches.

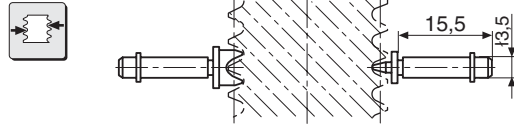

Anvils for root diameters

Metric thread (60°)			Whitworth thread (55°)			American UST-thread (60°) The same anvils are to be used as with the Whitworth-thread (55°).
Pitch mm	V-anvil Order no.	Blade Order no.	Pitch range tpi	V-anvil Order no.	Blade Order no.	
0.5	4173213	4173719	40	4173331	4173833	
0.6	4173214		36	4173321		
0.7	4173215		32	4173332		
0.75	4173216		28	4173333		
0.8	4173217		26	4173335		
0.9	4173218	4173723	24	4173336	4173840	
1	4173219		22	4173337		
1.25	4173221		20	4173338		
1.5	4173222		19	4173339		
1.75	4173223		18	4173340		
2	4173225	4173727	16	4173342	4173843	
2.5	4173226		14	4173343		
3	4173227		12	4173345		
3.5	4173229		11	4173346		
4	4173230		10	4173347		
4.5	4173231	4173731	9	4173349	4173851	
5	4173233		8	4173350		
5.5	4173234		7	4173451		
6	4173235		6	4173453		
7	4173237		5	4173454		
8	4173238	4173735	4.5	4173455	4173855	
9	4173239		4	4173457		
			3.5	4173458		
			3.25	4173459		
			3	4173460		

For outside diameters

Anvil 40 Za, flat

Measuring face dia. 7.5 mm
with 853 smallest
measurable O.D. dia. 5 mm

Hardened steel **Order no. 4173210**
Carbide tipped **Order no. 4511190**

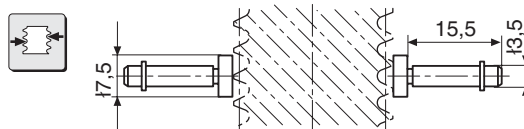

Interchangeable Anvils for 852 and 852 TS

Ball Anvils

For measuring gears and for special applications. Carbide ball. With cylindrical mounting shank and retainer ring.
For mounting into mounting bores of thread micrometers 40 Z and 852.

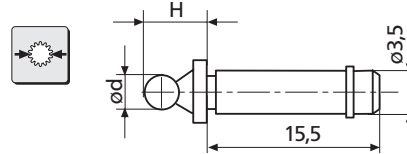

Shank dia. 3.5 mm
Shank length 15.5 mm
Manufacturing tolerance
Ball dia. $\pm 2 \mu\text{m}$

dia. d mm	H mm	Order no.	dia. d mm	H mm	Order no.	dia. d mm	H mm	Order no.
0.5	5.0	4179150	1.65	6.2	4179168	3.048	7.5	4179182
0.551	5.1	4179151	1.7	6.2	4179169	3.2	7.7	4170570
0.62	5.1	4179152	1.75	6.3	4170553	3.25	7.8	4170566
0.623	5.1	4179153	1.782	6.3	4179170	3.4	7.9	4179183
0.63	5.1	4179154	1.8	6.3	4179171	3.5	8.0	4170558
0.722	5.2	4179155	1.829	6.3	4179172	3.658	8.2	4179184
0.862	5.4	4179156	1.9	6.4	4179173	3.7	8.2	4170571
0.895	5.4	4179157	2	6.5	4170554	4	8.5	4170559
0.965	5.5	4179158	2.032	6.5	4170568	4.5	9.0	4170560
1	5.5	4170550	2.2	6.7	4170569	4.835	9.3	4179185
1.1	5.6	4179159	2.25	6.8	4170564	5	9.5	4170561
1.118	5.6	4179160	2.284	6.8	4179174	5.25	9.8	4179186
1.125	5.6	4179161	2.386	6.9	4179175	5.486	10.0	4179187
1.25	5.8	4170551	2.438	6.9	4179176	5.5	10.0	4170562
1.35	5.9	4179162	2.5	7.0	4170556	6	10.5	4170563
1.372	5.9	4179163	2.667	7.2	4179177	6.096	10.6	4179188
1.385	5.9	4179164	2.704	7.2	4179178	6.35	10.9	4179189
1.5	6.0	4170552	2.713	7.2	4179179	6.5	11.0	4170567
1.524	6.0	4179165	2.721	7.2	4179180	7	11.5	4170572
1.54	6.0	4179166	2.743	7.2	4179181	8	12.5	4170573
1.6	6.1	4179167	2.75	7.3	4170565	9	13.5	4170574
			3	7.5	4170557	10	14.5	4170575

Further sizes are available upon request (material: steel)

Roller Blades

For measuring gears and for special applications. The measuring roller is made of carbide.
To be mounted in the mounting bores of the 40 Z and 852.

Shank dia. 3.5 mm
Shank length 15.5 mm
Manufacturing tolerance
Ball dia. $\pm 2 \mu\text{m}$

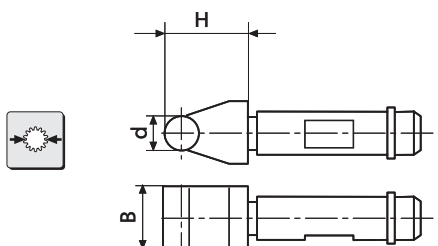

dia. d mm	Dimension H mm	Dimension B dia. mm	Order no.
1	5.5	5	4510200
1.25	5.8	5	4510201
1.5	6.0	5	4510202
1.75	6.3	5	4510203
2	6.5	5.5	4510204
2.5	7.0	5.5	4510206
3	7.5	5.5	4510207
3.5	8.0	5.5	4510208
4	8.5	5.5	4510209
4.5	9.0	5.5	4510210
5	9.5	6	4510211
5.5	10.0	6	4510212
6	10.5	6	4510213

Further sizes are available upon request (material: steel)

Portable Thickness Gages 22 P

Portable measurement of sheet materials and small parts

Features

- Indicator built into gage frame for maximum ruggedness.
- Lift-lever for one-hand operation.
- Continuous reading dials with revolution counter for absolute measurement of thin materials, plastic films, a small parts.
- 6.3 mm / .25" diameter, flat steel contacts.
- XLI Models (with μ Max μ m[®] XL Digital Indicator) can be Left/Right hand operated or front mounted and used with BA-26 Stand for bench applications.



22P-15



XLI-22P-20 with XLI-20000 μ Max μ m XL Digital Indicator (front mounted) and BA-26 Stand (Stand not included)



XLI-22P-20 with XLI-20000 μ Max μ m XL Digital Indicator

Technical Data

Metric	Inch	Capacity mm / <i>inch</i>	Throat Depth mm / <i>inch</i>	Graduation
22P-10M	22P-11	0 - 2.54 / 0-.10"	28.6 / 1.13"	.002 / .0001"
22P-15M	22P-15	0 - 12.70 / 0-.50"	50 / 2"	.01 / .001"
22P-20M	22P-20	0 - 25 / 0-1"	50 / 2"	.01 / .001"
XLI-22P-20		25 / 0-1"	50 / 2"	.001 / .00005" (Resolution)

Portable Thickness Gages 26 P



26P-7

Features

- Push-down movement.
- Molded body fits shape of hand; built-in indicator.
- Gage is normally open for easy part entry. Push-down button to close the contacts.
- Rugged and compact for roving inspection.
- 6.3 mm / .25" diameter, flat steel contacts.

Technical Data

Metric	Inch	Capacity mm / <i>inch</i>	Throat Depth mm / <i>inch</i>	Graduation mm / <i>inch</i>
26P-7M	26P-7	0-7.6 / 0-.30"	16 / .63"	.01 / .001"

Portable Thickness Gages 838

838 A



838 B



Features

- Rugged sturdy frame made from hard aluminum
- Built-in Digital or Dial Indicator
- With a lifting lever for the moveable upper measuring spindle
- Convenient heat insulated handle, open at one end
- Versions with a throat depth of 200 mm have a removable stand

Thickness Gage 838 A

- With flat measuring faces
- For measuring soft materials for example; foil, felt, rubber, paper and cardboard

Thickness Gage 838 B

- With spherical measuring faces
- For measuring hard materials for example; sheet metal, hardboard, wooden panels and panes of glass

Technical Data

	Throat depth		Measuring range		Measuring face dia.	Measuring face radius	Order no. with Indicator 810	Order no. with Indicator 1080	Order no. Wooden case
	mm	(inch)	mm	(inch)	mm	mm	0.01 mm Res	0.005/ .0001" Res	
838 A	50	(2")	0 - 20	(0 - .750")	11.3 = 1 cm ²	-	4495000	4495120	4495050
	100	(4")	0 - 20	(0 - .750")	11.3 = 1 cm ²	-	4495001	4495121	4495051
	200	(8")	0 - 20	(0 - .750")	11.3 = 1 cm ²	-	4495002	4495122	4495052
	50	(2")	0 - 20	(0 - .750")	20 = 3.14 cm ²	-	4495103	4495125	4495050
	100	(4")	0 - 20	(0 - .750")	20 = 3.14 cm ²	-	4495104	4495126	4495051
	200	(8")	0 - 20	(0 - .750")	20 = 3.14 cm ²	-	4495105	4495127	4495052
	50	(2")	0 - 20	(0 - .750")	30 = 7.06 cm ²	-	4495109	4495130	4495050
	100	(4")	0 - 20	(0 - .750")	30 = 7.06 cm ²	-	4495110	4495131	4495051
	200	(8")	0 - 20	(0 - .750")	30 = 7.06 cm ²	-	4495111	4495132	4495052
838 B	50	(2")	0 - 20	(0 - .750")	12	30	4495010	4495135	4495050
	100	(4")	0 - 20	(0 - .750")	12	30	4495011	4495136	4495051
	200	(8")	0 - 20	(0 - .750")	12	30	4495012	4495137	4495052

838 AB



Features

- Rugged sturdy frame made from hard aluminum
- Built-in Digital or Dial Indicator or Dial Comparator
- With a lifting lever for the moveable upper measuring spindle
- Convenient heat insulated handle, open at one end

Thickness Gage 838 AB

- Lower measuring face is flat
- Upper measuring face is spherical
- For measuring hard materials for example; sheet metal and hardboard

Technical Data

	Throat depth		Measuring range		Measuring face dia.		Measuring face radius		Order no.	Order no.	Order no.
	mm	(inch)	mm	(inch)	mm	mm	mm	mm	with Indicator 810	with Indicator 1080	Wooden case
838 AB flat / spherical	50	(2")	0 - 20	(0 - .750")	11.3 = 1 cm ²	30			4495504	4495140	4495050
	100	(4")	0 - 20	(0 - .750")	11.3 = 1 cm ²	30				4495141	4495051

	Throat depth		Measuring range		Measuring face dia.		Measuring face radius		Order no.	Order no.	Order no.
	mm	(inch)	mm	(inch)	mm	mm	mm	mm	with Indicator 1081	with Comparator 1003	Wooden case
838 AB flat / spherical	50	(2")	0 - 20	(0 - .750")	11.3 = 1 cm ²	30			4495145	4495519	4495050
	100	(4")	0 - 20	(0 - .750")	11.3 = 1 cm ²	30			4495146	4495517	4495051

Dead Load Thickness Gages 57B



XLI-57B-15

Features

- Solid casting with ribbed frame provides strength and rigidity for accurate measurements.
- 0.003 mm / .0001" parallelism with tables up to 19 mm / .75" diameter.
- 283 g / 10 oz. dead load weight for constant gaging pressure.
- 10 mm / .407" diameter flat upper 54.0 mm/ 2.125" lower contacts.
- Indicator mounts with adjustable back for quick positioning for each gaging requirement.
- Available with Dial Indicator or Digital Electronic Indicator.
- Gage is supplied with a lift lever so work can be easily placed between the table and contact.
- Four-inch throat depth for part clearance.

Technical Data

Metric	Order no.	Inch	Capacity mm / <i>inch</i>	Description
	57B-14M	57B-14	0-2.5 / 0-.10"	Dial Indicator readout with 2.5mm / .10" sensitive range and .002 mm / .0001" grads.
	57B-15M	57B-15	0-25 / 0-1"	Dial Indicator readout with 25mm / 1" sensitive range and .01 mm / .001" grads.
	XLI-57B-15			μMaxμm® XL Digital Indicator with 25mm / 1" range and .001 mm / .00005" resolution (Model XLI-50002).

*Alternate Indicators and contact points available upon request.
Contact Mahr Federal.*

Wire Insulation Thickness Gages 57B

For checking wall thickness of wire insulation and other small-diameter tubular parts



57B-13

Features

- Using the basic design of the Model 57B-13 (Model 57B-13M – Metric) Gage, the lower contact is PT-103, 1.10 mm / .043" diameter rod, mounted horizontally. The upper contact is a flat chisel contact, in line with the rod. By slipping tubular parts onto the lower contact, the gage can measure the thickness of the wall of the tube. An auxiliary weight on the Indicator provides a total dead-load weight of 25 grams. (Replacement lower rod: PS-43)

Technical Data

Metric	Order no.	Inch	Capacity mm / <i>inch</i>	Description
57B-13M	57B-13		7.62 / 0-.30"	Dial Indicator readout with 7.6 mm / .30" sensitive range and 0.01 mm / .0005" grads.
	XLI-57B-13			μ Max μ m® XL Digital Indicator with 25 mm / 1" range and 0.001 mm / .00005" resolution (Model XLI-50002).
Options				
	PT-2245			0.050 mm / .02" diameter Pin, Lower Contact Assembly

Measuring Compressible Materials

Compressible materials such as paper, plastics, rubber or fabrics must be measured under controlled conditions. Many materials have measurement standards specified by A.S.T.M., U.L., or other industry standards organizations. Measurement standards specify dead load weight, upper and lower contact configurations, and Indicator resolution.

Series 57B Gages are easily modified to meet most of these industry standards. Mahr Federal has on file designs for the measurement of paper, latex foam rubber, sponge rubber, vulcanized rubber, asbestos tape and cloth, sheet and roll felt, and many other materials. When inquiring, specify A.S.T.M. Specification Number, if possible.

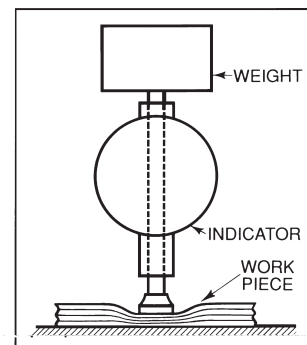

Thickness Gages 57B Bench Style



57B-12

Features

- Solid casting with ribbed frame provides strength and rigidity for accurate measurements.
- Gage is furnished with a lift lever so work can be easily placed between the contacts.
- Large 54 mm/ 2.125" diameter lower anvil provides convenient stage for small parts or flat materials.
- 4.75 mm/ .187" diameter radiused upper contact normally provided.
- 102 mm/ 4" throat depth for part clearance.
- Indicator mounts with adjustable back for quick positioning for each gaging requirement.
- Available with Dial Indicator or Digital Electronic Indicator.

Technical Data

Metric	Order no.	Inch	Capacity mm / <i>inch</i>	Description
	57B-11M	57B-11	0-25 / 0-1"	Dial Indicator readout with 25 mm / 1" sensitive range and .01 mm / .001" grads.
	XLI-57B-11			µMaxµm® XL Digital Indicator with 25 mm/ 1" range and .001 mm / .00005" resolution (Model XLI-50002).
	EMD-57B-11		0-21.5 / 0-.85"	Maxµm/// Digital Indicator with selectable range and resolution, 2033101.
	EDI-57B-11			µMaxµm Digital Indicator with 2 mm / .08" sensitive range, .0005 mm / .00002" resolution (Model EDI-20101).
	57B-12M	57B-12	0-12.5 / 0-.5"	Dial Indicator readout with 12.50 mm/ .50" sensitive range and .01 mm / .0005" grads.
	XLI-57B-12			µMaxµm® XL Digital Indicator with 12.50 mm / .50" range and .001 mm / .00005" resolution (Model XLI-10002).

*Alternate Indicators and contact points available upon request.
Contact Mahr Federal.*

Caliper Gages 49P

The most widely used gages for checking medium tolerance dimensions on patterns, castings, forgings, dies, sheet metal.



49P

Features

- The most widely used gages for checking medium tolerance dimensions on patterns, castings, forgings, dies, sheet metal.
- Generous clearance on jaws reaches over non-measured part protrusions for easy access to areas where thickness must meet critical dimensional specs.
- Retraction lever is conveniently located for one-hand operation.
- .02 mm or .1 mm / .01", .001", or 1/64" grads. available.
- Continuous reading dials with revolution counters normally provided.
- Cylindrical radius steel contact tips normally furnished.

Technical Data

Metric	Order no.	Inch	Capacity* mm / inch	Gaging Depth mm / inch	Minimum Graduation mm / inch	A	B
49P-17M	49P-17		0 - 50 / 0 - 2"	100 / 4"	0.02 / .001" grads.	1-1/4	1-1/4
49P-19M	49P-19		0 - 50 / 0 - 2"	200 / 8"	0.02 / .001" grads.	2-9/16	2
49P-1M	49P-1		0 - 75 / 0 - 3"	100 / 4"	0.1 / .01" grads.	1-1/4	1-1/4
49P-2M	49P-2		0 - 75 / 0 - 3"	200 / 8"	0.1 / .01" grads.	2-9/16	2

* Ordinarily this gage is used as a comparator. The actual measuring range of the instrument is 38 mm / 1.50".
If the gage is used for direct linear measurement, chordal errors may need to be corrected.
Contact Mahr Federal Technical Assistance for details.

Special Applications

Series 49P and 149P Caliper Gages have many design possibilities. Specially shaped arms of various lengths can be designed to reach inaccessible spots or get around obstructions to make measurements possible which might otherwise go unchecked. For alternate contact shapes or materials, alternate capacities and gaging depths, and special designs to meet your application contact Mahr Federal Technical Assistance.

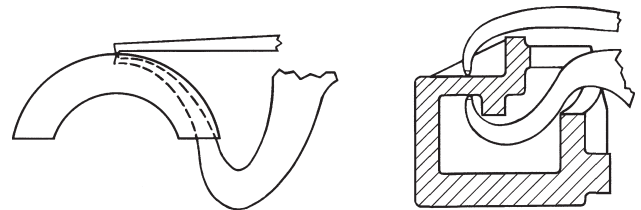

Gages (Metric) for External Measurement 838 TA to measure thickness and wall thicknesses

Features

- For measuring thicknesses and wall thicknesses
- Easy to operate, very habile and portable
- Easy to read tolerance markers
- Dust and splash waterproof
- Contact points are made from carbide
- Absolute measuring instrument
- Supplied with: Test certificate



Type A
Measuring range 0-20 mm, Order no. 4495551

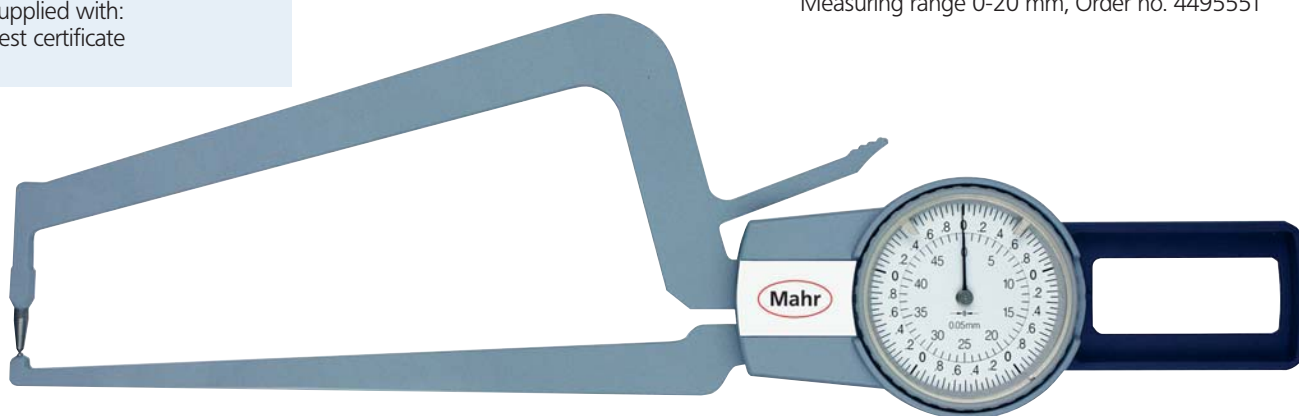

Type B with handle
Measuring range 0-50 mm, Order no. 4495554

Technical Data and Dimensions

			Type A			Type B	
Measuring range	Meb	mm	0 - 10	0 - 20	0 - 20	0 - 50	0 - 50
Readings	Skw	mm	0.005	0.01	0.01	0.05	0.05
Error limit	G	mm	0.015	0.03	0.03	0.05	0.05
Repeatability limit	r	mm	0.005	0.01	0.01	0.025	0.025
Measuring depth	L	mm	35	85	85	170	170
Contact point - length (move.)	Hb	mm	19.1	24.6	24.6	32	32
Contact point - length (fixed)	Hf	mm	18.6	24.6	2.5	32	1
Contact point - ball dia.	D	mm	1.5 ¹⁾	1.5 ¹⁾	1.5 ²⁾	2 ¹⁾	2 ²⁾
Measuring force	F	N	0.8 - 1.2	1.1 - 1.6	1.1 - 1.6	1.2 - 1.8	1.2 - 1.8
Protection class			IP65	IP65	IP65	-	-
Order no.			4495550	4495551	4495552	4495553	4495554

Applications

1)

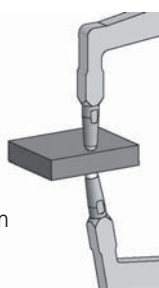

Ball dia. 1.5 mm
Ball dia. 2 mm
Ball dia. 3 mm

2)

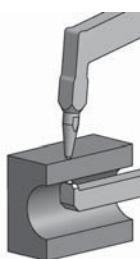

Ball dia. 1.5 mm
Ball dia. 2 mm
Ball dia. 3 mm

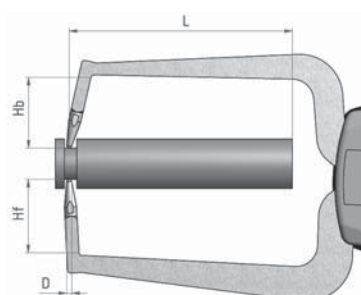

Gages (Inch) for External Measurement 838 TA to measure thickness and wall thicknesses

Features

- For measuring thicknesses and wall thicknesses
- Easy to operate, very habile and portable
- Easy to read tolerance markers
- Dust and splash waterproof
- Contact points are made from carbide
- Absolute measuring instrument
- Supplied with: Test certificate



Type A

Measuring range 0 - .80 inch, Order no. 4495951

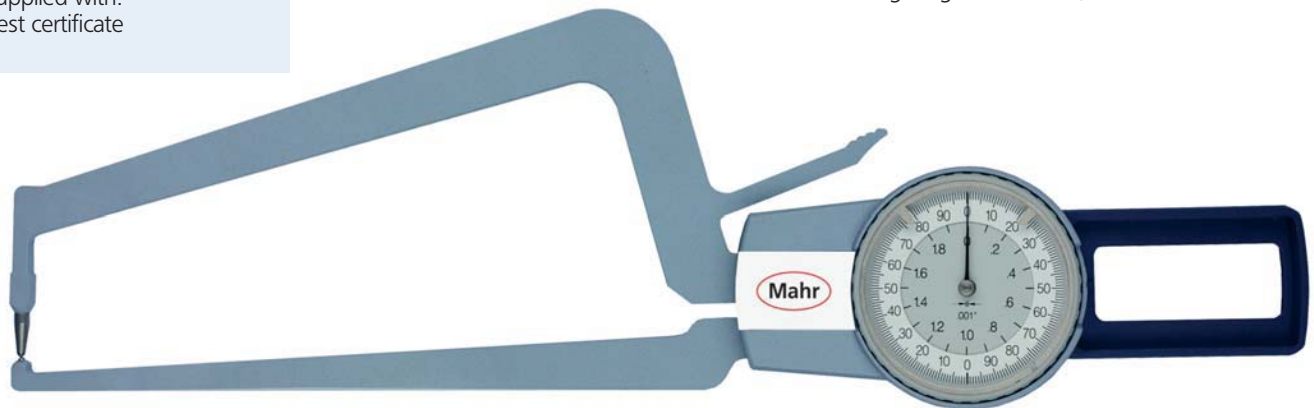

Type B with handle

Measuring range 0 - 2.0 inch, Order no. 4495954

Technical Data and Dimensions

			Type A			Type B	
Measuring range	Meb	inch	0 - .40	0 - .80	0 - .80	0 - 2.0	0 - 2.0
Readings	Skw	inch	.0002	.0005	.0005	.001	.001
Error limit	G	inch	.0008	.0015	.0015	.002	.002
Repeatability limit	r	inch	.0002	.0005	.0005	.001	.001
Measuring depth	L	inch	1.38	3.35	3.35	6.69	6.69
Contact point - length (move.)	Hb	inch	0.73	0.97	0.97	1.26	1.26
Contact point - length (fixed)	Hf	inch	0.73	0.97	0.09	1.26	0.04
Contact point - ball dia.	D	inch	0.05 ¹⁾	0.05 ¹⁾	0.05 ²⁾	0.08 ¹⁾	0.08 ²⁾
Measuring force	F	N	0.8 - 1.2	1.1 - 1.6	1.1 - 1.6	1.2 - 1.8	1.2 - 1.8
Protection class			IP65	IP65	IP65	-	-
Order no.			4495950	4495951	4495952	4495953	4495954

Applications

1)

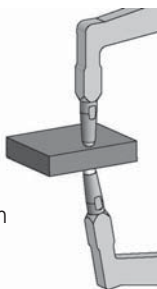

Ball dia. 1.5 mm
Ball dia. 2 mm
Ball dia. 3 mm

2)

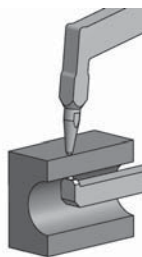

Ball dia. 1.5 mm
Ball dia. 2 mm
Ball dia. 3 mm

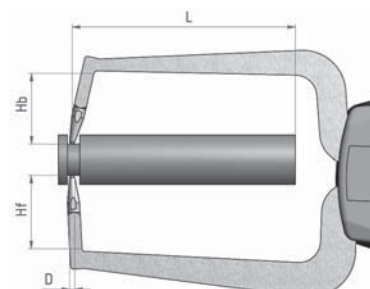

Electronic Gages for External Measurement 838 EA to measure thickness and wall thicknesses

Features

- High contrast analog and digital LCD
- Specified measuring programs according to application
- Absolute/Relative measuring program
- Tolerance is displayed with 2 LEDs
- mm/inch switchable
- Protection class IP67 or IP63 according to EN 60529
- Supplied with:
Test certificate
Battery



Type A
Measuring range 0-20 mm, Order no. 4495561

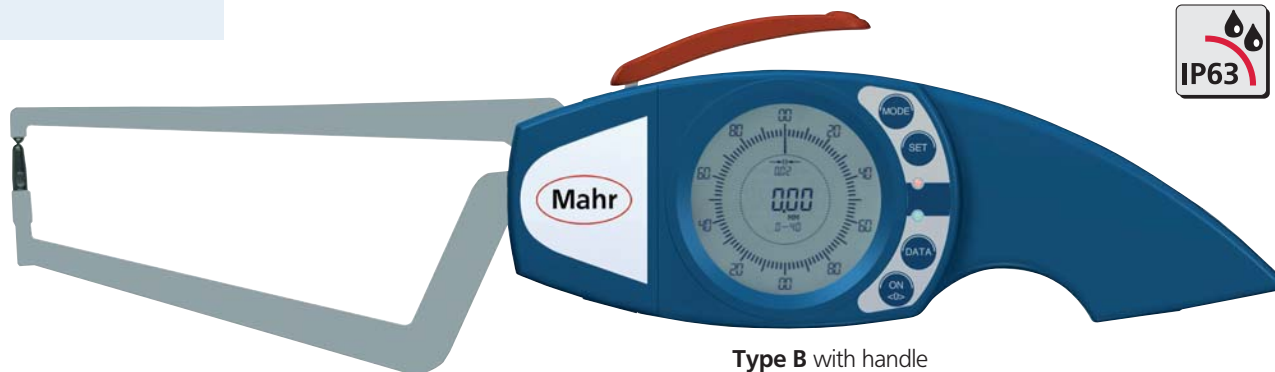

Type B with handle
Measuring range 0-40 mm, Order no. 4495167

Technical Data and Dimensions

			Type A			Type B	
Measuring range	Meb	mm	0 - 10	0 - 20	0 - 20	0 - 40	0 - 40
Resolution	Skw	mm	0.005	0.01	0.01	0.02	0.02
Error limit	G	mm	0.015	0.03	0.03	0.04	0.04
Repeatability limit	r	mm	0.005	0.01	0.01	0.02	0.02
Measuring depth	L	mm	35	85	85	115	115
Contact point - length (move.)	Hb	mm	19.1	24.6	24.6	25	25
Contact point - length (fixed)	Hf	mm	18.6	24.6	2.5	25	1
Contact point - ball dia.	D	mm	1.5 ¹⁾	1.5 ¹⁾	1.5 ²⁾	3 ¹⁾	3 ²⁾
Measuring force	F	N	0.8 - 1.2	1.1 - 1.6	1.1 - 1.6	1 - 1.5	1 - 1.5
Protection class			IP67	IP67	IP67	IP63	IP63
Order no.			4495560	4495561	4495562	4495059	4495167

Accessories

	Order no.
Digimatic interface incl. data connection cable for Type A	838 di 4495083
Digimatic interface incl. data connection cable for Type B	838 di 4495084
Battery Alkaline AAA 1.5 V for Type A*	4243073
Battery Alkaline AA 1.5 V for Type B	4243072

* 2 batteries are required

Electronic Gages for Internal Measurement 838 EI for measuring bores and internal grooves

Features

- High contrast analog and digital LCD
- Specified measuring programs according to application
- Absolute/Relative measuring program
- Tolerance is displayed with 2 LEDs
- mm/inch switchable
- Protection class IP67 or IP63 according to EN 60529
- Supplied with:
Test certificate
Battery



Type A

Measuring range 10-30 mm, Order no. 4495591



Type B with handle

Measuring range 15-55 mm, Order no. 4495596

Technical Data and Dimensions

			Type A						Type B	
			5 - 15	10 - 30	20 - 40	30 - 50	40 - 60	50 - 70	15 - 55	35 - 75
Measuring range	Meb	mm	5 - 15	10 - 30	20 - 40	30 - 50	40 - 60	50 - 70	15 - 55	35 - 75
Resolution	Skw	mm	0.005	0.01	0.01	0.01	0.01	0.01	0.02	0.02
Error limit	G	mm	0.015	0.03	0.03	0.03	0.03	0.03	0.04	0.04
Repeatability limit	r	mm	0.005	0.01	0.01	0.01	0.01	0.01	0.02	0.02
Measuring depth	L	mm	35	85	85	85	85	85	114	114
Groove depth	A	mm	2.3	5.2	7.0	7.0	8.3	8.3	4.5	8
Groove width	B	mm	0.8	1.2	1.2	1.2	1.2	1.2	2.5	3
Contact point - length (move.)	Hb	mm	2.5	5.4	7.3	7.3	12.2	12.2	6	8.5
Contact point - length (fixed)	Hf	mm	2.5	5.4	7.3	7.3	12.2	12.2	6	8.5
Contact point - ball dia.	D	mm	0.6	1	1	1	1	1	1.5	2
Measuring force	F	N	0.8 - 1.2	1.1 - 1.6	1.1 - 1.6	1.1 - 1.6	1.1 - 1.6	1.1 - 1.6	1.2 - 1.7	1.3 - 1.8
Protection class			IP67	IP67	IP67	IP67	IP67	IP67	IP63	IP63
Order no.			4495590	4495591	4495592	4495593	4495594	4495595	4495596	4495597

Accessories

	Order no.	Order no.
Digimatic interface incl. data connection cable for Type A	838 di 4495083	Battery Alkaline AAA 1.5 V for Type A* 4243073
Digimatic interface incl. data connection cable for Type B	838 di 4495084	Battery Alkaline AA 1.5 V for Type B 4243072
		* 2 batteries are required

Gages (Metric) for Internal Measurement 838 TI for measuring bores and internal grooves

Features

- For measuring bores and internal grooves
- Easy to operate, very stabile and portable
- Easy to read tolerance markers
- Dust and splash waterproof
- Contact points are made from carbide
- Absolute measuring instrument
- Supplied with: Test certificate



Type A
Measuring range 10-30 mm, Order no. 4495581

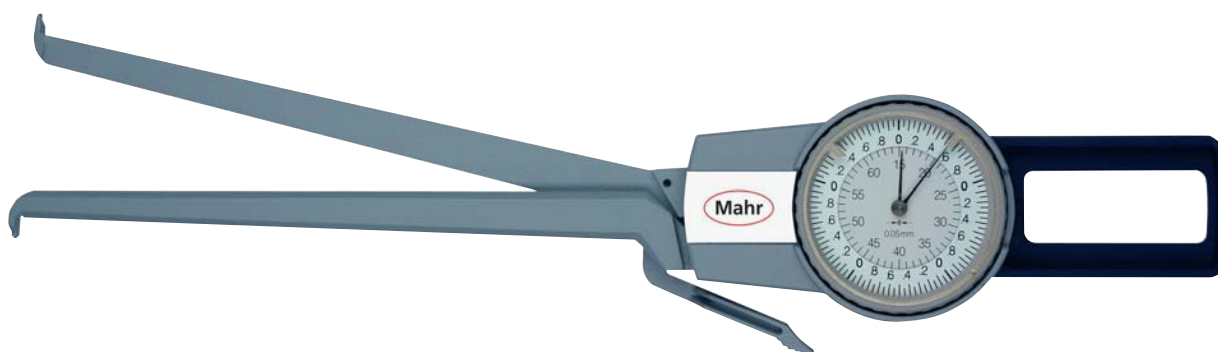

Type B with handle
Measuring range 15-65 mm, Order no. 4495076

Technical Data and Dimensions

			Type A						Type B	
Measuring range	Meb	mm	5 - 15	10 - 30	20 - 40	30 - 50	40 - 60	50 - 70	15 - 65	40 - 90
Readings	Skw	mm	0.005	0.01	0.01	0.01	0.01	0.01	0.05	0.05
Error limit	G	mm	0.015	0.03	0.03	0.03	0.03	0.03	0.05	0.05
Repeatability limit	r	mm	0.005	0.01	0.01	0.01	0.01	0.01	0.025	0.025
Measuring depth	L	mm	35	85	85	85	85	85	175	175
Groove depth	A	mm	2.3	5.2	7.0	7.0	8.3	8.3	4.5	8
Groove width	B	mm	0.8	1.2	1.2	1.2	1.2	1.2	2.5	2.5
Contact point - length (move.)	Hb	mm	2.5	5.4	7.3	7.3	12.2	12.2	5.3	8.5
Contact point - length (fixed)	Hf	mm	2.5	5.4	7.3	7.3	12.2	12.2	5.3	8.5
Contact point - ball dia.	D	mm	0.6	1	1	1	1	1	1.5	2
Measuring force	F	N	0.8 - 1.2	1.1 - 1.6	1.1 - 1.6	1.1 - 1.6	1.1 - 1.6	1.1 - 1.6	1.2 - 2	1.2 - 2
Protection class			IP65	IP65	IP65	IP65	IP65	IP65	-	-
Order no.			4495580	4495581	4495582	4495583	4495584	4495585	4495076	4495077

Application

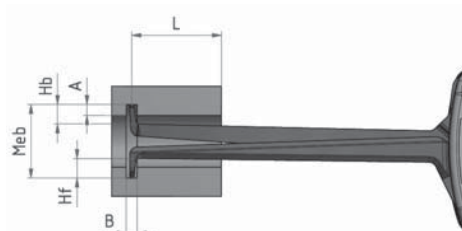

Gages (Inch) for Internal Measurement 838 TI for measuring bores and internal grooves

Features

- For measuring bores and internal grooves
- Easy to operate, very hable and portable
- Easy to read tolerance markers
- Dust and splash waterproof
- Contact points are made from carbide
- Absolute measuring instrument
- Supplied with: Test certificate



Type A

Measuring range 10-30 mm, Order no. 4495981

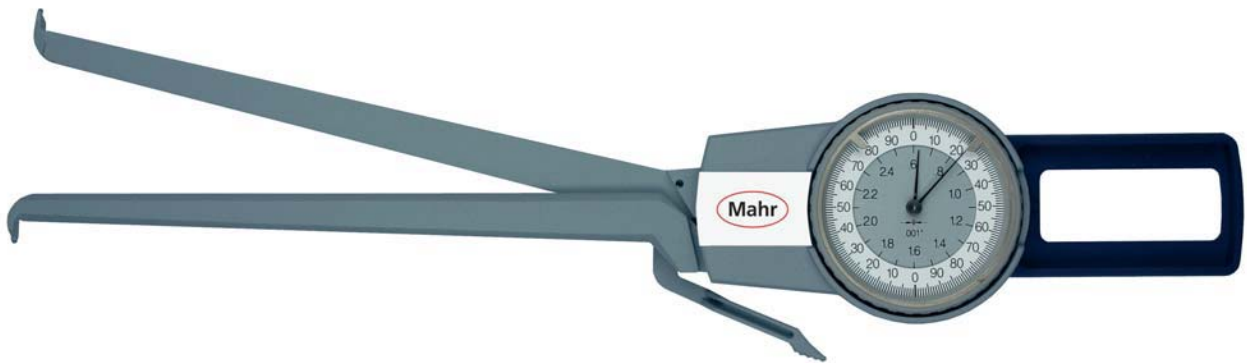

Type B with handle

Measuring range 15-65 mm, Order no. 4495476

Technical Data and Dimensions

			Type A						Type B	
Measuring range	Meb	inch	.20 - .60	.10 - 1.20	.80 - 1.60	1.20 - 2.00	1.60 - 2.40	2.00 - 2.80	.60 - 2.60	1.60 - 3.60
Readings	Skw	inch	.0002	.0005	.0005	.0005	.0005	.0005	.001	.001
Error limit	G	inch	0.015	0.03	0.03	0.03	0.03	0.03	0.05	0.05
Repeatability limit	r	inch	0.005	0.01	0.01	0.01	0.01	0.01	0.025	0.025
Measuring depth	L	inch	35	85	85	85	85	85	175	175
Groove depth	A	inch	2.3	5.2	7.0	7.0	8.3	8.3	4.5	8
Groove width	B	inch	0.8	1.2	1.2	1.2	1.2	1.2	2.5	2.5
Contact point - length (move.)	Hb	inch	2.5	5.4	7.3	7.3	12.2	12.2	5.3	8.5
Contact point - length (fixed)	Hf	inch	2.5	5.4	7.3	7.3	12.2	12.2	5.3	8.5
Contact point - ball dia.	D	inch	0.6	1	1	1	1	1	1.5	2
Measuring force	F	N	0.8 - 1.2	1.1 - 1.6	1.1 - 1.6	1.1 - 1.6	1.1 - 1.6	1.1 - 1.6	1.2 - 2	1.2 - 2
Protection class			IP65	IP65	IP65	IP65	IP65	IP65	-	-
Order no.			4495980	4495981	4495982	4495983	4495984	4495985	4495476	4495477

Application

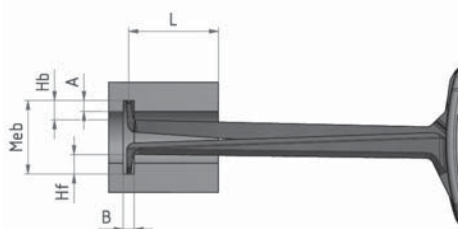

Definition of Terms Specifications for inspection and test acceptance procedure of mechanical and electronic caliper gages

1. Basics

The inspection only follows approximately the testing methods and procedures of the German standard DIN 878 for dial gages and the testing statements for caliper gages according to VDI/VDE/DGQ 2618 sheet 12.1 and 13.1. The gages are referred to without special reference as gages for 'absolute' measurements and adjustable zero point.

2. Definitions

Definitions of length checking techniques see DIN 2257 part 1 and part 2 (see Illustration).

2.1 Application range Awb

Application range Awb of a gage corresponds to the sum of adjusting and measuring range.

2.2 Measuring range Meb

The measuring range of an indicating gage represents the range of measuring values in which agreed error limits must not be exceeded.

2.3 Reading Zw

The reading Zw of a numerical interval of a numerical scale is the modification of the value of a measured variable that causes the modification of the indication by one interval. The numerical interval corresponds to the scale interval of a line scale and is indicated in the unity of the measured variable.

2.4 Scale interval Skw

The scale interval Skw is indicated on the scale, i.e. 0.01 mm. It corresponds to the measuring value between two scale graduation marks.

2.5 Deviation within the measuring range f_M

The deviation within the measuring range (range of deviation) f_M represents the distance of ordinates between the highest and the lowest position in the deviation diagram when the movable caliper arm closes. The **error limits** G for f_M is symmetrically positioned to the zero line and is indicated as ± f_{Mzul}.

The deviation in the partial measuring range f_i can only be determined by using electronic testing methods during the preparation of certificates of quality.

2.6 Repeatability f_w

Repeatability f_w is a characteristic value for deviations of the measured variable within the measuring range in the same motion direction of the movable caliper arm (usually n is 5).

The limits of error f_w are referred to with **repeatability limit r**.

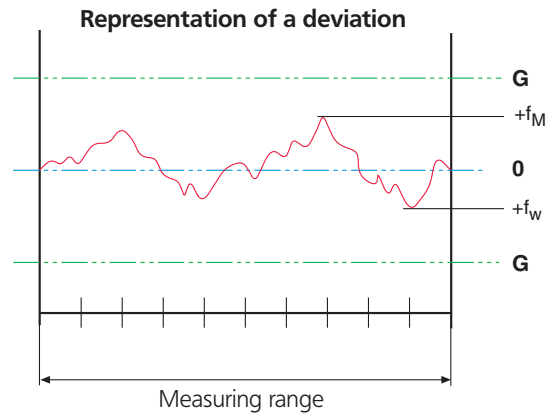

Measuring Capacity of Internal Measuring Instruments

Data listed in the table referring to groove depth A, groove width B and measuring depth L are only meant to be rough guidelines.

For each type of instrument there is dependence of these three values from each other and on the application range Awb. This is shown in the adjacent table of examples. For each inside measuring instrument this table is available upon request in connection with a detailed data sheet.

Groove depth A (mm)	Application range Awb (mm)										
	10	11	12	13	14	15	16	17	18	19	20
0	0/55	0/55	0/56	0/56	0/57	0/57	0/57	0/57	0/57	0/57	0/58
0.5		1.4/55	1.4/56	1.4/56	1.4/56	1.4/56	1.4/56	1.4/56	1.4/57	1.4/57	1.4/57
1			1.4/56	1.4/56	1.4/56	1.4/56	1.4/56	1.4/56	1.4/56	1.4/56	1.4/57
1.5				1.4/55	1.4/55	1.4/55	1.4/55	1.4/56	1.4/56	1.4/56	1.4/56
2					1.4/55	1.4/55	1.4/55	1.5/55	1.5/55	1.5/56	1.5/56
2.5						1.4/55	1.5/55	1.5/55	1.6/55	1.6/55	1.6/55
3							1.5/54	1.6/54	1.6/55	1.6/55	1.6/55
3.5								1.6/54	1.6/54	1.6/54	1.6/55
4									1.7/54	1.7/54	1.7/54
4.5										1.7/53	1.8/54

Relationship B/L

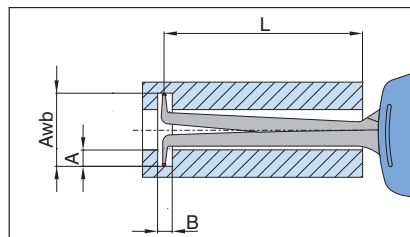

B = Min. groove depth (mm)
L = Max. usable caliper arm length (mm)

Example: Awb = 12 B = 1.4
 A = 0.5 L = 56

Indicating Depth Gage 65P-40, 75P-30 and 837

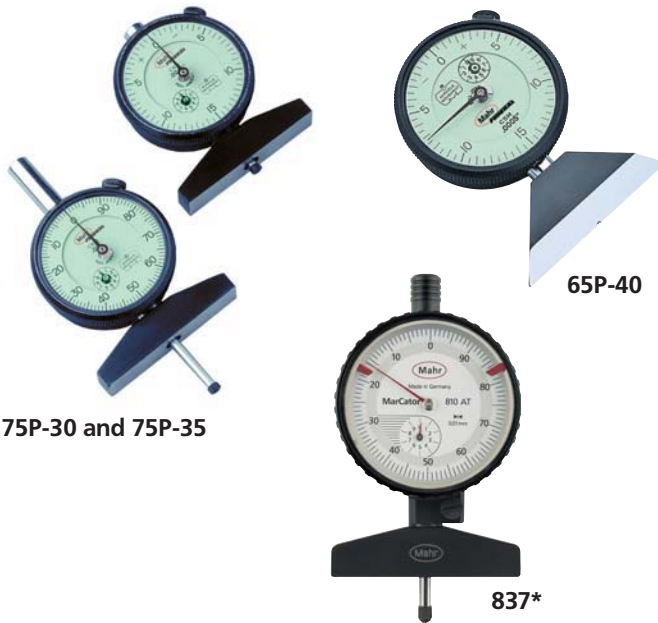

Features

- **65P-40** has a "V" shaped base and a needle contact. Movement is "Push-Down" style. Ideal for measuring etch depth, pits, or small, shallow recesses.
- **75P-30** Depth Gages have rectangular, flat base and a radiused contact point. 75P-30 is supplied with contact point, for measuring depths from the base as a reference. Contact points for other depths are available upon request.
- **75P-35** Depth Gages have three interchangeable contact points, allowing inspection of depths to 76 mm / 3". Check depths against a setting master.
- **837** has a large cross beam with hardened and ground contact surface as well as mounting clamp for dial indicator.

Technical Data

Order no. Metric	Order no. Inch	Capacity	Range of Sensitive	Graduation Contact	Base Dimensions	Contact Style/ Length
65P-40M	65P-40	0-2 mm / 0-.075"	0-2 mm / 0-.075"	0.01 mm / .0005"	64 mm / 2.50"	Needle
75P-30M	75P-30	0-4 mm / 0-.15"	0-4 mm / 0-.15"	0.01 mm / .0005"	64x14 mm / 2.5x.56"	radiused: 3 mm / .13"
75P-35M	75P-35	0-75 mm / 0-3"	0-75 mm / 0-3"	0.01 mm / .001"	64x14 mm / 2.5x.56"	(3) radiused: 3 mm / .13" 28 mm / 1.13" 54 mm / 2.13"

Model	Range	Range with Anvils (837v)	Beam length	Beam width	Mounting hole dia.	Order no.
837	0-10 mm	0-100 mm	60 mm	12 mm	8 mm	4494000*

* Indicator not included.

Indicating Instruments

All indicating instruments that has a 8 mm mounting shank may be used. However the Dial Indicator 810 AT is recommended due to its large measuring range.

Readings 0.01 mm
Measuring range 10 mm

Order no. 4311060

Other alternatives are Digital Indicators 1075 or 1086, please refer to Chapter 5 for more information.

Accessories

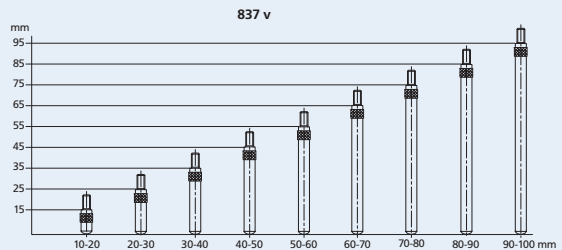

Anvil Set 837 v
Set of 9 anvils in increments of 10 mm. Spherical measuring faces, M 2.5 connection thread

Order no. 4494009

Wooden case
Accommodates the Depth Gage, a Dial Indicator and Anvils

Order no. 4494001

Depth Gages 75P-50



75P-52 with Setting Master

Features

- Modular depth gages for all applications.
- Single and multi-purpose bases with choice of Dial Indicator for comparative or direct measurement.
- Indicator collet mounting allows easy interchangeability of Indicators and bases — use one Indicator with several bases or change Indicators to meet range requirements.
- Family of contact points available to cover wide range of depth measurement applications.
- Setting masters available with anvil ground to specified depth (± 0.0025 mm / $\pm .0001$ " in accuracy).

Technical Data

• **For Comparative Measurement:** Unless otherwise specified, a comparative measurement Indicator will be furnished. Correct contact point will be furnished for the gaging depth specified.

Metric: Furnished with .01 mm grads. / 2.50 mm range, balance dial.

Inch: Furnished with .0005" grads. / .075" range, balanced dial.

• **For Direct Measurement:** (Special Order) Contact point for 0-25 mm / 0-1" depth will be furnished unless otherwise specified.

Metric: Model SP6IS (0.01 mm grads. / 25 mm range, continuous dial with revolution counter).

Inch: Model 281SN (.001" grads. / 1" range, continuous dial with revolution counter).

Digital: Model XLI-20000 (.001 mm/.00005" resolution, 25 mm / 1" range)

• For long range models contact Mahr Federal.

Base Dimensions (all bases are 15 mm / .59" high x 19 mm / .75" wide)

Order no.	Length	Width	Diameter	Measuring Positions	Base only Model*	
Metric	Inch	mm / inch	mm / inch			
75P-50M	75P-50	50 / 2"	19 / .75"	—	One	BA-42
75P-51M	75P-51	76 / 3"	19 / .75"	—	One	BA-43
75P-52M	75P-52	102 / 4"	19 / .75"	—	Two	BA-44
75P-53M	75P-53	152 / 6"	19 / .75"	—	Three	BA-45
75P-54M	75P-54	203 / 8"	19 / .75"	—	Three	BA-46
75P-55M	75P-55	—	—	19 / .75"	One	BA-47
75P-56 M	75P-56	—	—	32 / 1.25"	One	BA-76

Ordering Information

When ordering please specify:

1. Model Number.
2. Comparative or Direct Measurement.
3. Depth to be gaged.
4. Master Setting Block, if required.
5. Any special or optional features such as special contact points, Indicator Housing, or alternate Indicators.

* If base only is specified, it is supplied without the indicator holding collet, model AD-87.

Order collet separately if required.

Contact Points

To increase the versatility of any **75P-50** Series Depth Gage, additional contacts may be used to extend the capacity of the gage. Specify additional contact points required from the table at right.

To order the entire set of points, order by Model **PT-750** Contact Point Set.

Gaging Depth mm / <i>inch</i>	Contact Point model*	μ Max μ m
0.00 - 1.60 / 0 - .063"	PT-201	PT-564
1.60 - 4.80 / .063 - .188"	PT-232	PT-14
4.80 - 8 / .188 - .313"	PT-305	PT-564
8 - 11 / .313 - .438"	PT-565	PT-31
11 - 14 / .438 - .563"	PT-239	PT-201
14 - 17.50 / .563 - .688"	PT-50	PT-232
17.50 - 21 / .688 - .813"	PT-235	PT-305
21 - 24 / .813 - .938"	PT-241	PT-565
24 - 27 / .938 - 1.063"	PT-100	PT-239
27 - 30 / 1.063 - 1.188"	PT-51	PT-50
30 - 33.40 / 1.188 - 1.313"	PT-243	PT-235
33.4 - 37 / 1.313 - 1.438"	PT-696	PT-241
37 - 40 / 1.438 - 1.563"	PT-101	PT-100
40 - 43 / 1.563 - 1.688"	PT-245	PT-51
43 - 46 / 1.688 - 1.813"	PT-102	PT-243
46 - 49 / 1.813 - 1.938"	PT-566	PT-696
49 - 52.4 / 1.938 - 2.063"	PT-247	PT-101

* For "C" size dial indicators, "EDI-" and "XLI-" μ Max μ m Digital Indicators.

Semi-finished Model

0-25 mm/ 0-1"	25-50 mm/ 1-2"	Gaging Positions	Used with Model	"A"	"B"	"C"	"D"
MR-501	MR-502	One	75P-50, 75P-30/35	25 mm/ 1"	25 mm/ 1"	—	—
MR-511	MR-512	One	75P-51	38 mm/ 1.5"	38 mm/ 1.5"	—	—
MR-521	MR-522	Two	75P-52	50 mm/ 2"	25 mm/ 1"	25 mm/ 1"	—
MR-531	MR-532	Three	75P-53	75 mm/ 3"	25 mm/ 1"	25 mm/ 1"	25 mm/ 1"
MR-541	MR-542	Three	75P-54	102 mm/ 4"	25 mm/ 1"	25 mm/ 1"	25 mm/ 1"
MR-551	MR-552	One	75P-55, 75P-56	17 mm/ .68"	17 mm/ .68"	—	—

Six different setting masters are available for Series 75P Models. Setting masters are available in two styles: Finished (ground to final size) and Semi-finished (assembled but not ground to final size). Finished depths available from 0 - 50 mm / 0 - 2". Unground Anvil can be purchased separately. Specify **Model AL-89**.

For multi-position masters, please specify the anvil location. Protective Housings for the Dial Indicator are available, see page 5-23.

For Series 75P-50 style depth gages with alternate Indicators, greater gaging depth, alternate contact configurations or other modifications, contact Mahr Federal Technical Assistance.

For master finished to size, specify size and add suffix "F". Example: MR-502F, size 1.265" (Master for 75P-50 set to 1.265").

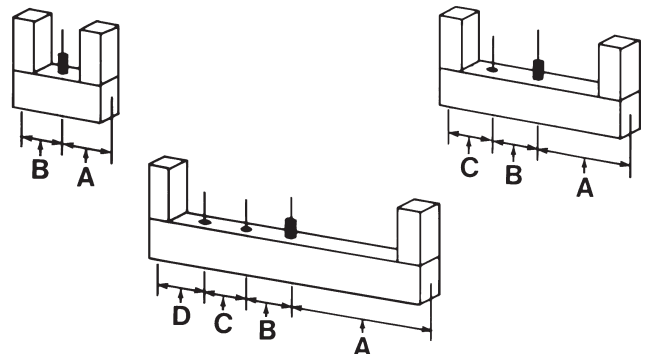

Bench Depth Gages 75B-1

For inspecting small parts



75B-1

Features

- Available with Dial Indicator (75B-1 Models) or Maxµm® III and µMaxµm Digital Electronic Indicators (EMD-75B and XLI-75B Models).
- Two contact points provided, 6 mm / .25" and 32 mm / 1.25" to check features up to 50 mm / 2" deep.
- 89 x 102 mm / 3.50 x 4" hardened, ground work surface provides excellent reference surface.
- Four #10-32 tapped holes provided for mounting part location fixturing.
- Indicator adjustable vertically over 32 mm / 1.25".

Technical Data

Order no. Metric	Inch	Indicator Range / Graduation or Resolution
75B-1M	75B-1	25 mm / .01 mm (1" / .001") graduation Dial Indicator.
EMD-75B-1		Maxµm III Digital Indicator with selectable range and resolution, 2033201.
XLI-75B-1		µMaxµm XL Digital Indicator, 25 mm / 1" range, .001 mm / .00005" resolution
XLI-75B-2		µMaxµm XL Digital Indicator, 12 mm / .50" range, .001 mm / .00005" resolution

To specify Digital Output on EMD-75B Models, add suffix "D". Example = EMD-75B-1D.
Output is standard with XLI and EDI models.

Dimentron® Plug Inside Diameter Gages



Thru-hole and Blind Hole
Dimentron Plugs

Features

- Designed for high production I.D. gaging.
- High chrome content; hardened stainless steel bodies ground precisely for specified size measurement.
- Plug tooling interchangeable for quick changeover.
- Measuring is easy – just insert plug into diameter and read. No rocking needed.
- Set to nominal dimension with a single master ring.
- Long life: Tungsten carbide contacts and vee rod ensure durable motion transfer.
- Three styles of plugs available – Thru-hole, Blind Hole and Super-blind.
- Open design rinses clean easily.
- Explore bores for taper, barrel shape, bell-mouth and 2-point out-of-round.
- Stop Collars available for all standard sizes.
- Captive vee rod design.

Technical Data

Blind Hole Plugs***

Use Dimension "A" below. Dimension "B" is 4 mm / .157".

Super-blind Plugs

Use Dimension "A" below. Dimension "B" is 2 mm / .08", for 5.5 mm / .217" & up .108" for 3.2 mm / .125" to 5.5 mm / .217"

Super-Super blind Plugs

Use Dimension "A" below. Dimension "B" is 0.79 mm / .031". (4.500" to 9.00" are not available with this model.)

Dimentron Plug Dimensions

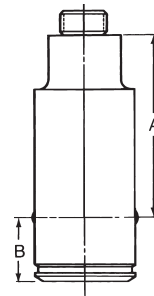

Blind Hole Plugs



Thru-hole Plugs

Sizes above mm / inch	To and include mm / inch	A mm / inch	B mm / inch	Group*
3.2 / .125"	5.5 / .217"	30.4 / 1.2"	6.4 / .25"	no group**
5.5 / .217"	8.2 / .322"	34.8 / 1.37"	6.5 / .256"	5
8.2 / .322"	9.5 / .375"	34.8 / 1.37"	6.5 / .256"	6
9.5 / .375"	12.7 / .50"	35.4 / 1.39"	13 / .512"	8
12.7 / .50"	19.05 / .75"	35.4 / 1.39"	13 / .512"	8
19.05 / .75"	25 / 1"	48.3 / 1.90"	16 / .63"	12
25 / 1"	38 / 1.50"	48.3 / 1.90"	16 / .63"	12
38 / 1.50"	63 / 2.50"	46.7 / 1.84"	19 / .748"	12
63 / 2.50"	114.3 / 4.5"	46.7 / 1.84"	19 / .748"	12
114.3 / 4.50"	228.6 / 9.0"	46.7 / 1.84"	9.5 / .375"	12

* Group Number specifies thread size on gaging plugs. Threaded bushings are provided with each plug to allow mounting to Maxum® Adaptor or Electronic Handle Assembly.

** Only available as Thru- and Blind Hole Small Bore Probe. For larger or smaller plugs, alternate contact materials, extended gaging depths, more clearance, or other plug modifications - contact Mahr Federal Technical Assistance.

*** A blind-hole, Dimentron Plug Gage with µMaxum® Digital Electronic Indicator makes a compact, lightweight portable hand tool.

Dimetron® Plug Inside Diameter Gages



Dimetron Plug Assembly
shown with Maxum®III Indicator,
Housing and Handle

Ordering Information

When ordering specify:

1. Diameter
2. Tolerance
3. Gaging depth
4. Plug style
5. Contact type — polished chrome steel or tungsten carbide
6. Stop collar

Gaging Range:

Dimetron Plugs are ground to one of four measuring ranges, based on part tolerance.

Technical Data

Sizes above	To and include	Metric M01	M02	Maximum Part Tolerance		
				Inch 050	100	M05
mm / inch	mm / inch	mm / inch	mm / inch	mm / inch	mm / inch	mm / inch
3.18 / .1250"	3.62 / .1426"	±0.025 / ±.0010"	±0.038 / ±.0015"			
3.62 / .1426"	5.52 / .2171"	±0.025 / ±.0010"	±0.046 / ±.0018"	±0.076 / ±.0030"		
5.50 / .2171"	7.94 / .3125"	±0.025 / ±.0010"	±0.046 / ±.0018"	±0.069 / ±.0027"	±0.102 / ±.0040"	
7.94 / .3125"	9.50 / .375"	±0.030 / ±.0012"	±0.051 / ±.0020"	±0.069 / ±.0027"	±0.127 / ±.0050"	
9.50 / .3750"	12.7 / .500"	±0.038 / ±.0015"	±0.058 / ±.0023"	±0.086 / ±.0034"	±0.137 / ±.0054"	
12.7 / .5000"	19.05 / .750"	±0.038 / ±.0015"	±0.069 / ±.0027"	±0.102 / ±.0040"	±0.165 / ±.0065"	
19.05 / .750"	25.4 / 1.000"	±0.038 / ±.0015"	±0.076 / ±.0030"	±0.127 / ±.0050"	±0.180 / ±.0071"	
25.4 / 1.000"	38 / 1.500"	±0.038 / ±.0015"	±0.076 / ±.0030"	±0.152 / ±.0060"	±0.221 / ±.0087"	
38 / 1.500"	114.3 / 4.50"		±0.076 / ±.0030"	±0.152 / ±.0060"	±0.254 / ±.0100"	
114.3 / 4.5"	229 / 9.00"			±0.152 / ±.0060"	±0.254 / ±.0100"	

Order Maxum Indicator and Accessories separately.

Maxum III Indicator

Inch: Specify **2033101** (**2033111** if Digital Output is required) for .00005" resolution, .0001" grad., and "0" on the Indicator in the 12 o'clock position.
For "0" at 6 o'clock position, specify **2033201**.

Metric: Specify **2033101** (**2033111** if Digital Output is required) for 0.001 mm resolution, 0.001 mm grad., and "0" at 12 o'clock.
For "0" at 6 o'clock position, specify **2033201**.

EKT-1120-W1 is required to mount the Maxum III Indicator to Dimetron Plugs. (Specify **EKT-1120-W2** for Maxum III Indicators with 8 mm stems). This adaptor kit includes mounting adaptor, hex wrench, and flat-end, carbide faced contact point for the Indicator.

Other models include:

- EKT-1120-W3** — EDI/Dial .375" stem — 4-48 thread
- EKT-1120-W4** — EDI/Dial 8 mm stem — 2.5 thread
- EKT-1120-W6** — 1002 - 1010 8 mm stem — 2.5 thread

Protective Housings for Plugs over 50 mm/ 2"

EHG-1172 For Maxum III Indicators without Output. Requires in-line or pistol style grip Handle (**HA-88** Handle and **AT-124** Adaptor).
EHG-1198 For Maxum III Indicators with Output. Requires pistol style grip Handle (**HA-88** and **AT-124** Adaptor).

B-12668 For Maxum III Indicators with Output. Complete with in-line style handle. **AT-125** Bench Stand Adaptor permits the Maxum Indicator in a Protective Housing to be clamped in **BA-26** Bench Stand. (See pages 9-5 and 9-7)

Dimentron® Plug Inside Diameter Gages

With Electronic Gage Heads

Gage heads are mounted to Dimentron Plugs using HA-88 and AD-140 Adaptor. Electronic Gage Heads can be ordered separately. The following Handle Assemblies include Adaptor, Wrenches and Gage Head:

Handle Assemblies

Order no.	Description
EHA-1146	Flat Contact 3 m / 11 ft, coiled cable
EHA-1145	Flat Contact 1.5 m / 5 ft, straight cable

Accessories

Base, BA-100

Heavy cast base has tooling plate allowing plug to be mounted vertically or horizontally. Can be used with Electronic Gage Heads or Maxµm Remote Transducers or Maxµm/// Digital Transducers.

Stop Collars

Stop collars are available for all Dimentron Plugs.



Right Angle Adaptor
AT-155

Extensions

Extensions for Dimentron Plugs are available for Plugs over 9.5 mm / .375". See table below:

Group 8 Plugs 9.3 mm/.366" O.D.	Group 12 Plugs 16 mm/.63" O.D.	Extension Length
EX-204	EX-210	50 mm/ 1.97"
EX-205	EX-211	100 mm/ 3.94"
EX-206	EX-212	200 mm/ 7.87"

Consists of 1280P Indicator and Handle Assembly with stocked adaptor:

	Order no.		Minimum graduation
Inch	550P-10	Dial Indicator	.0001"
Metric	550P-20	Dial Indicator	.002 mm
	EDI-550P-10	(with EDI-50102*)	.00005"/.001 mm
	EDI-550P-20	(with EDI-20102)	.00002"/.0005 mm

* no output



EDI-550P-10



Remote Maxµm Transducer or Maxµm///
Digital Transducer Dimentron Plug
Handle/ Adaptor: HA-141



BA-100 (Dimentron Plug
not included)

Dimentron® Plug Inside Diameter Gages

This table depicts available readouts for Dimentron Plug Inside Diameter Gages. After making a Plug selection, follow the chart for all the components needed to make up a gaging system suited to your application.

Dimentron Plug Gage	Adaptors	Handles	Readout	Housing Housings	Handle
---------------------	----------	---------	---------	------------------	--------

Dimentron Plug

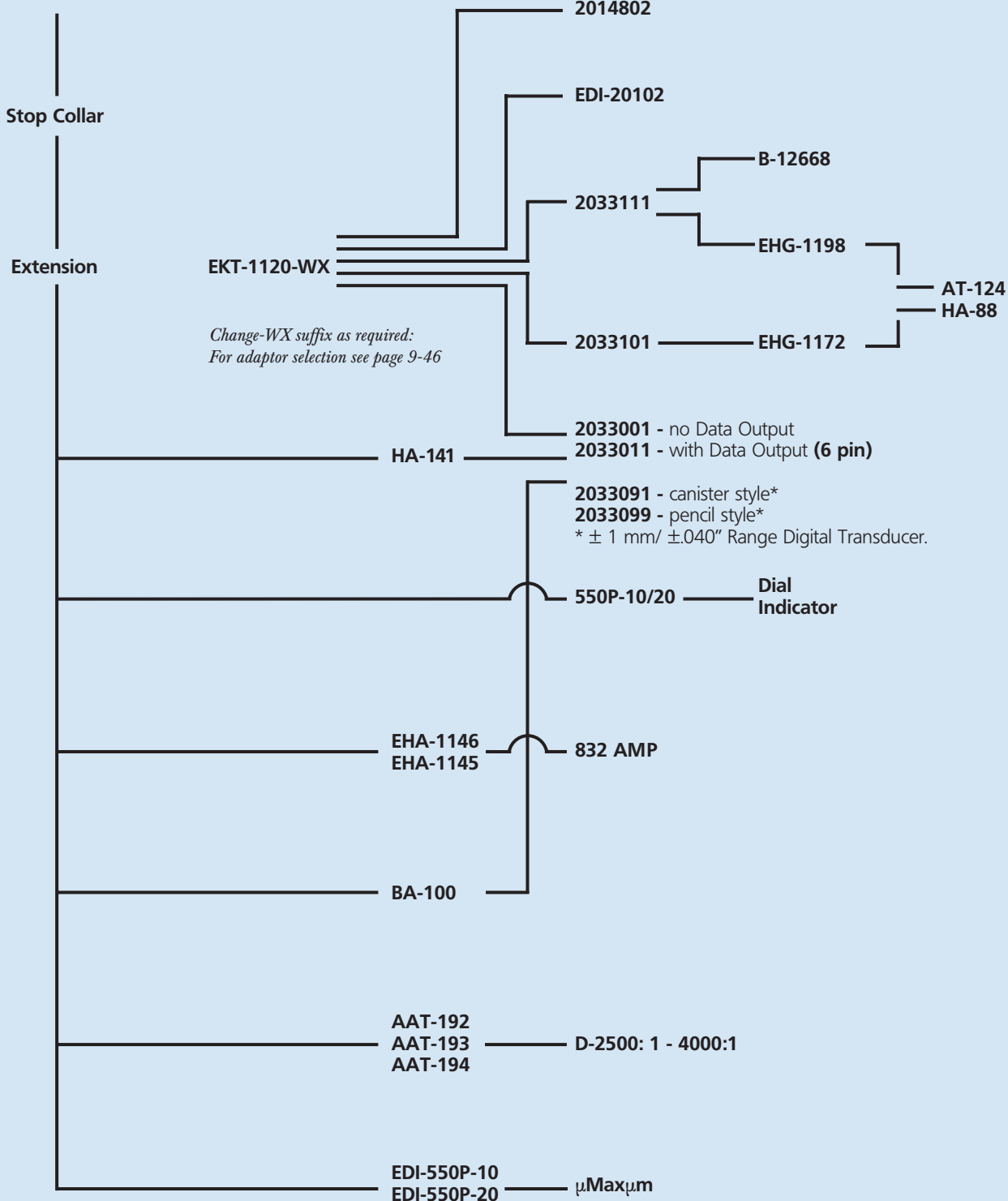

Indicating Plug Gages 844 D



Features

- For the rapid testing of diameter, roundness and conicity of bores
- Especially suitable for testing batches with tight tolerances
- No rocking in the bore is required to determine the reversal point
- Therefore ideal for use in conjunction with a digital indicating instrument and for subsequent processing of measured values
- Measuring head has a hardened chromium plated guide cylinder and carbide tipped anvils
- The carbide expanding pin transfers radial movement to indicating instrument
- Constant measuring force as a result of built-in spring, thus eliminating user influence
- Measuring head, holder, depth extension, right angle attachments and depth stops are part of an extensive modular system

Technical Data of the Measuring Heads

Nominal diameter of the bore	Measuring range starting from the minimum bore dimension to be measured			
	844 Dk/844Dkr		844 Dks (from 4 mm)	
2.98 - 8 mm	= -0.02	+0.1 mm	= -0.02	+0.1 mm
over 8 - 16 mm	= -0.02	+0.15 mm	= -0.02	+0.15 mm
over 16 - 32 mm	= -0.02	+0.2 mm	= -0.02	+0.15 mm
over 32 - 70 mm	= -0.03	+0.2 mm	= -0.03	+0.15 mm
over 70 - 200 mm	= -0.04	+0.2 mm	= -0.04	+0.15 mm

When placing an order please quote the nominal diameter and tolerances, for example:

Bore diameter	Tolerance	
	35 D7	+ 80
35 H7	+ 0	+25 μm
35 R7	- 50	-25 μm

The diameter of the guide cylinder is produced between 0.02 and 0.07 mm smaller than the minimum dimension of the bore to be checked.

Example:

Plug Gage 844 Dk for bore 35 D7
 Nominal diameter: 35 mm
 Minimum dimension: 35.080 mm
 Maximum dimension: 35.105 mm
 Meas. range: 35.050 - 35.280 mm

Accuracy

Hysteresis	f_u	$\leq 0.4 \mu\text{m}$
Repeatability	f_w	$\leq 1 \mu\text{m}$
Linearity		$\leq 1 \%$
Linearity 844 Dks >16 mm		$\leq 2 \%$

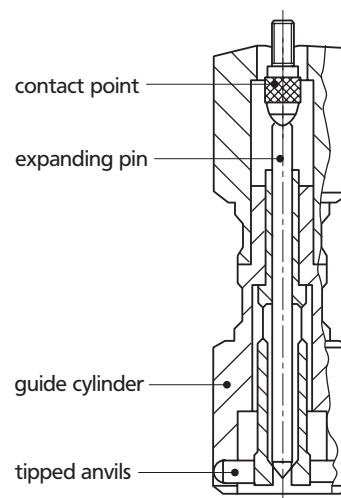

Plug Gages

Measuring Head 844 Dk, Standard version

	Nominal ^① diameter		Manufacturing ^② tolerance	Meas. range ^③ dia. d	Order no.
	mm	mm	mm		
over	2.98 - 3.99		-0.02/-0.04	0.1	4480184* 4478200*
	3.99 - 8		-0.02/-0.04	0.1	
over	8	- 16	-0.02/-0.04	0.15	4478201
over	16	- 25	-0.02/-0.05	0.2	4478202 4478204 4478205
over	25	- 32	-0.02/-0.05	0.2	
over	32	- 44	-0.02/-0.06	0.2	
over	44	- 50	-0.03/-0.06	0.2	4478206 4478207 4478208
over	50	- 60	-0.03/-0.06	0.2	
over	60	- 70	-0.03/-0.06	0.2	
over	70	- 80	-0.04/-0.07	0.2	4478209 4478210 4478211 4478212 4478213 4478214 4478215 4478216 4478217 4478218 4478219 4478220 4478221
over	80	- 90	-0.04/-0.07	0.2	
over	90	-100	-0.04/-0.07	0.2	
over	100	-110	-0.04/-0.07	0.2	
over	110	-120	-0.04/-0.07	0.2	
over	120	-130	-0.04/-0.07	0.2	
over	130	-140	-0.04/-0.07	0.2	
over	140	-150	-0.04/-0.07	0.2	
over	150	-160	-0.04/-0.07	0.2	
over	160	-170	-0.04/-0.07	0.2	
over	170	-180	-0.04/-0.07	0.2	
over	180	-190	-0.04/-0.07	0.2	
over	190	-200	-0.04/-0.07	0.2	

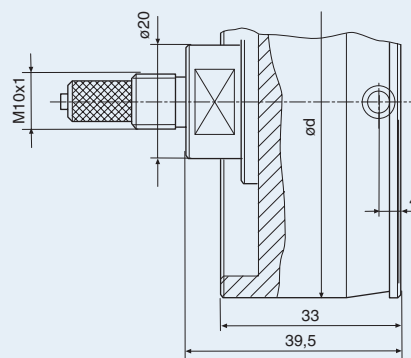
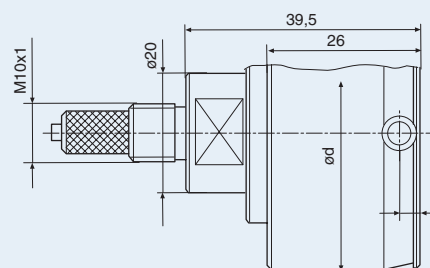
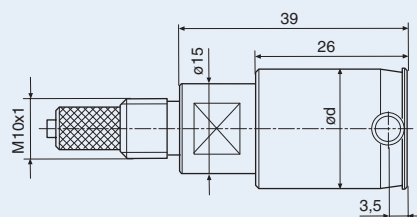
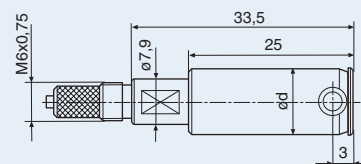
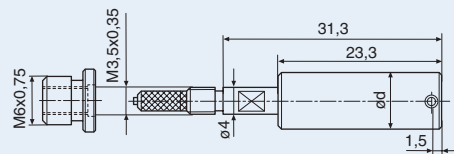

① Nominal diameter = smallest bore diameter
② dia. d in reference to the smallest bore diameter

③ Measuring range refers to the nominal diameter
* With Adaptor for connection to the holder

Plug Gages

Measuring Head 844 Dks, for blind holes, to measure almost to the base of a bore

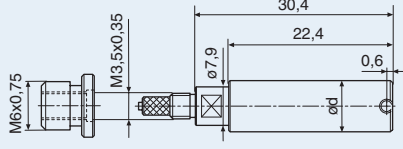
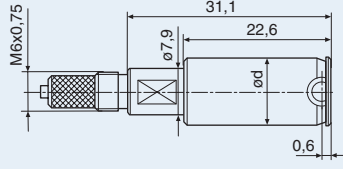
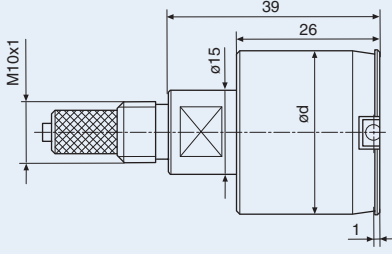
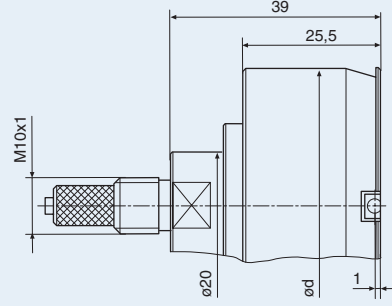
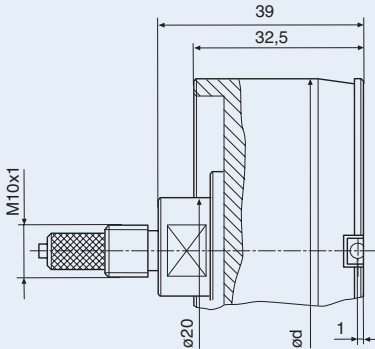
	Nominal ^① diameter mm	Manufacturing ^② tolerance mm	Meas. range ^③ dia. d mm	Order no.	
	4 - 8	-0.02/-0.04	0.10	4478285*	
over	8 - 16	-0.02/-0.04	0,15	4478245	
over	16 - 25	-0.02/-0.05	0.15	4478230	
over	25 - 32	-0.02/-0.05	0.15	4478232	
over	32 - 44	-0.02/-0.06	0.15	4478233	
over	44 - 50	-0.03/-0.06	0.15	4478234	
over	50 - 60	-0.03/-0.06	0.15	4478235	
over	60 - 70	-0.03/-0.06	0.15	4478236	
over	70 - 80	-0.04/-0.07	0.15	4478237	
over	80 - 90	-0.04/-0.07	0.15	4478238	
over	90 - 100	-0.04/-0.07	0.15	4478239	
over	100 - 110	-0.04/-0.07	0.15	4478240	
over	110 - 120	-0.04/-0.07	0.15	4478241	
over	120 - 130	-0.04/-0.07	0.15	4478242	
over	130 - 140	-0.04/-0.07	0.15	4478243	
over	140 - 150	-0.04/-0.07	0.15	4478244	

① Nominal diameter = smallest bore diameter

② dia. d in reference to the smallest bore diameter

③ Measuring range refers to the nominal diameter

* With adaptor for connection to the holder

Plug Gages

Measuring Head 844 Dkr, with an extended guide cylinder to measure through holes from the edge of a bore, ideal for narrow parts

	Nominal ^① diameter mm	Manufacturing ^② tolerance mm	Meas. range ^③ dia. d mm	Order no.	
over	2.98 - 3.99	-0.02/-0.04	0.1	4478272*	
	3.99 - 8	-0.02/-0.04	0.1	4478250*	
over	8 - 16	-0.02/-0.04	0.15	4478251	
over	16 - 25	-0.02/-0.05	0.2	4478252	
over	25 - 32	-0.02/-0.05	0.2	4478254	
over	32 - 44	-0.02/-0.06	0.2	4478255	
over	44 - 50	-0.03/-0.06	0.2	4478256	
over	50 - 60	-0.03/-0.06	0.2	4478257	
over	60 - 70	-0.03/-0.06	0.2	4478258	
over	70 - 80	-0.04/-0.07	0.2	4478259	
over	80 - 90	-0.04/-0.07	0.2	4478260	
over	90 - 100	-0.04/-0.07	0.2	4478261	
over	100 - 110	-0.04/-0.07	0.2	4478262	
over	110 - 120	-0.04/-0.07	0.2	4478263	
over	120 - 130	-0.04/-0.07	0.2	4478264	
over	130 - 140	-0.04/-0.07	0.2	4478265	
over	140 - 150	-0.04/-0.07	0.2	4478266	
over	150 - 160	-0.04/-0.07	0.2	4478267	
over	160 - 170	-0.04/-0.07	0.2	4478268	
over	170 - 180	-0.04/-0.07	0.2	4478269	
over	180 - 190	-0.04/-0.07	0.2	4478270	
over	190 - 200	-0.04/-0.07	0.2	4478271	

① Nominal diameter = smallest bore diameter

② dia. d in reference to the smallest bore diameter

③ Measuring range refers to the nominal diameter

* With adaptor for connection to the holder

Modular Unit System 844 D

Standard Holder 844 Kg/844 Dg - Standard version

With locking clamp for an indicating instrument and a connecting thread for a measuring head. Heat insulated handle. The model 844 Dg is made from **Invar steel**.

Cat. no.	Connecting thread g	Length L mm	Handle dia. D mm	Order no.
844 Kg	M6 x 0.75	50	14	4470851
844 Dg	M10 x 1	150	26	4478851

Short Holder 844 Dgk - Short version

With locking clamp for an indicating instrument and a connecting thread for a measuring head. Heat insulated handle.

Cat. no.	Connecting thread g	Length L mm	Handle dia. D mm	Order no.
844 Dgk	M10 x 1	61	26	4478050

Holder 844 Dge for Inductive Measuring Probes

With long sleeve for shock and waterproof mounting of inductive measuring probes. Strain relief clamp for probe cable. Threaded connection for measuring heads. Heat insulated handle.

Cat. no.	Connecting thread g	Length L mm	Handle dia. D mm	Order no.
844 Dge	M6 x 0.75	195	33	4478020
	M10 x 1	195	33	4478021

Right Angle (Elbow) Attachment

For measuring difficult to reach bores, e.g. in tight spaces, on a machine tool or when work piece bores are inconveniently located. For screwing in between holder and measuring head.

Cat. no.	Connecting thread g mm	Elbow		Order no.
		Length L mm	Height H mm	
844 Kw	M6 x 0.75	26.5	22.5	4470110
844 Dw	M10 x 1	36.7	17	4478110

844 Kg / 844 Dg

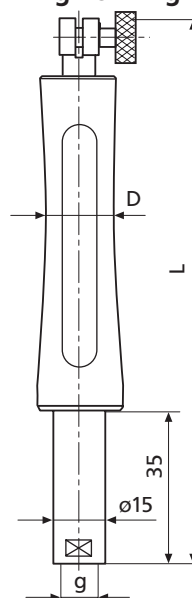

844 Dgk

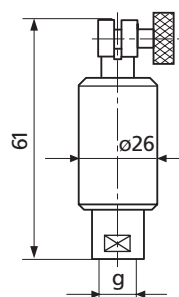

844 Dge

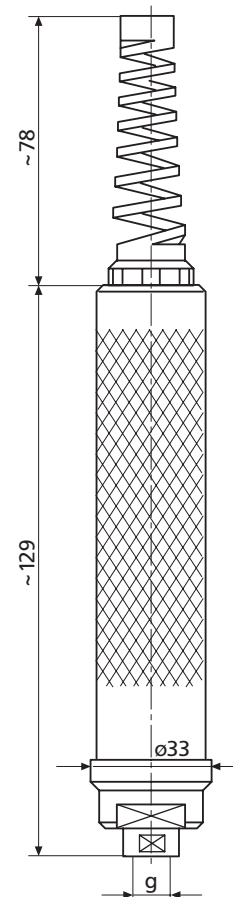

844 Kw / 844 Dw

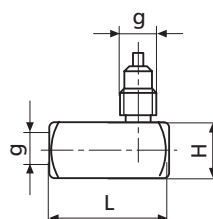

Modular Unit System 844 D

Extensions

For extra-deep bores. Screws in between holder and measuring heads. Several extensions can be screwed together as of 8 mm. Models 844 Dv and 844 Dvk made of **Invar steel**.

Cat. no.	Connecting thread g	Length L mm/inch	dia. D mm/inch	Order no.
844 Dvk	M6x0.75/M3.5x0.35	64/ 2.5"	3.8 / .15"	4478080
844 Kv	M6 x 0.75	64/ 2.5"	8 / .32"	4470070
844 Dv	M10 x 1	64/ 2.5"	15 / .6"	4478070
844 Dv	M10 x 1	80/ 3"	15 / .6"	4478071
844 Dv	M10 x 1	100/ 4"	15 / .6"	4478072
844 Dv	M10 x 1	125/ 5"	15 / .6"	4478073
844 Dv	M10 x 1	250/10"	15 / .6"	4478074
844 Dv	M10 x 1	500/20"	15 / .6"	4478075

Depth Stops

For limiting depth of insertion of measuring head in bore. Can be attached to Extensions 844 Kv or 844 Dv. With clamping screw.

Cat. no.	Mounting hole dia. d mm/inch	Stop surface dia. A mm/inch	Order no.
844 Kt	8 / .32"	24 / 1"	4470115
844 Dt	15 / .6"	45 / 1.8"	4478115
844 Dt	15 / .6"	75 / 3"	4478116
844 Dt	15 / .6"	110 / 4.3"	4478117
844 Dt	15 / .6"	160 / 6.3"	4478118
844 Dt	15 / .6"	220 / 8.6"	4478119

Depth Stop Rings

For limiting depth of insertion of measuring head in bore. Clamped onto the measuring head.

Cat. no.	Mounting hole dia. d mm	Stop surface dia. A mm/inch	Height h mm/inch	Order no.
844 Dtr	3 - 5	27 / 1.1"	10 / .4"	4478130
	5 - 8	30 / 1.2"	10 / .4"	4478130
	8 - 11	33 / 1.3"	10 / .4"	4478130
	11 - 15	37 / 1.5"	10 / .4"	4478130
	15 - 20	42 / 1.7"	10 / .4"	4478130
20 - 25	51 / 2.0"	12 / .5"	4478131	
25 - 30	56 / 2.2"	12 / .5"	4478131	
30 - 35	61 / 2.4"	12 / .5"	4478131	
35 - 40	66 / 2.6"	12 / .5"	4478131	
40 - 44	71 / 2.8"	12 / .5"	4478131	
44 - 50	76 / 2.9"	12 / .5"	4478132	
50 - 60	86 / 3.4"	12 / .5"	4478132	
60 - 70	96 / 3.8"	12 / .5"	4478132	
70 - 80	106 / 4.1"	12 / .5"	4478132	
80 - 90	116 / 4.6"	12 / .5"	4478133	
90 - 100	126 / 4.9"	12 / .5"	4478133	

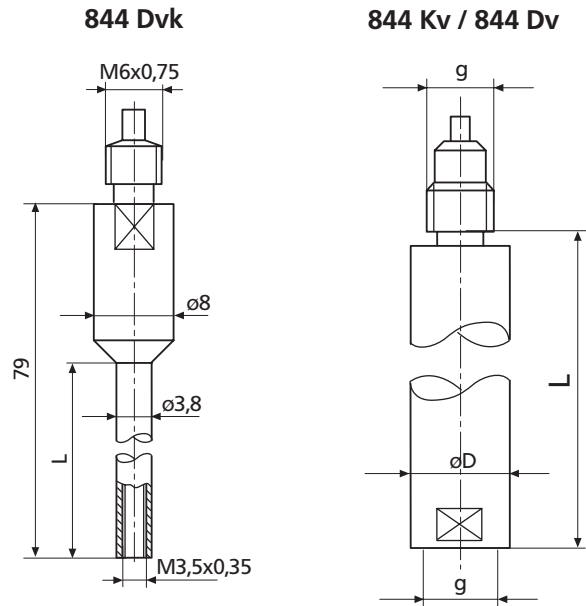

844 Kt / 844 Dt

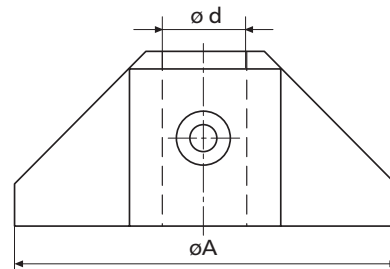

844 Dtr

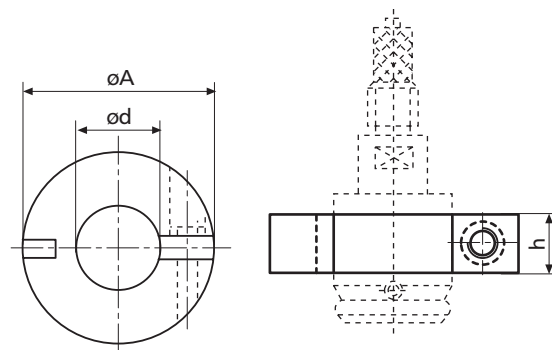

Modular units	Diameter of Measuring Heads		
	2.98 - 8 mm	8 - 16 mm	over 16 mm
844 Kg	4470851		
844 Dg	4478851		
844 Dgk	4478050		
844 Dge	4478020		4478021
844 Dvk 844 Kv 844 Dv	4478080	4470070	4478070 to 4478076
844 Kt 844 Dt		4470115	4478115 to 4478119
844 Kw 844 Dw	4470110		4478110
844 Dk 844 Dks 844 Dkr			
355 E	see page 9-44		

Modular unit	Diameter of Measuring Heads			
	2.98 - 20 mm	20 - 44 mm	44 - 80 mm	80 - 100 mm
844 Dtr	4478130	4478131	4478132	4478133

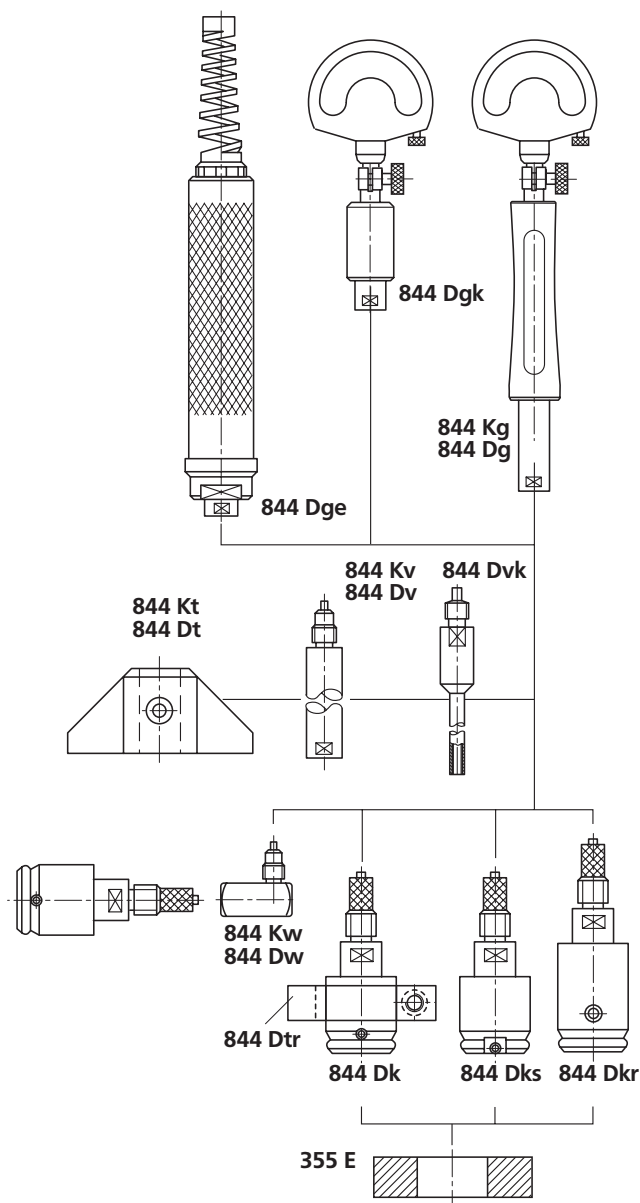

Indicating Instruments

All indicating instruments that has a 8 mm mounting shank may be used. Recommended are:

Indicator	Readings	Order no.
Compramess 1004	5 μm	4333000
Millimes 1003	1 μm	4334000
Supramess 1002	0.5 μm	4335000
Extramess 2000	0.2 μm , 0.5 μm , 1 μm	4346000
Extramess 2001	0.2 μm , 0.5 μm , 1 μm	4346100
Millimar C 1208	± 3 , 10, 30, 100, 300, 1000 μm	5312080
Millimar S 1840	± 10 , 30, 100, 300, 1000 μm	5330001
	3000 μm , 10000 μm	

Digital Indicators see Chapter 5

Electrical Indicating Instruments see Chapter 7

Adjustment of Plug Gages 844 D

Ring Gage 355 E:

Special wear-resistant gage steel. Hardened and lapped. With actual deviation engraved.

Dimensions: DIN 2250, type C
 Manufacturing tolerance: DIN 2250
 Available diameters: 0.5-200 mm

Self-Centering Dial Bore Gages 844 K Intramess



Features

- Measuring the diameter, roundness and conicity of bores
- Spring-loaded halves of measuring probe are split via expanding pin with precision lapped taper. This movement is transferred to indicating instrument
- Maximum wear-resistance due to hard chrome plating. From 4 mm alternatively with carbide tipped available on request
- Constant measuring force as a result of built-in spring thus eliminating user influence
- Highly versatile, each gage covers a large range. Within the respective limits, quickly and easily adjustable to any size and any type of measuring application
- Measuring probe, holder, depth extensions, right-angle attachments and depth stops are part of an extensive modular system
- Supplied with: Holder, probe, expanding pin and a wooden case, excludes an indicating instrument

Technical Data

Complete Instrument

- 844 K** Measuring heads hard chrome plated, expanding pin made of stainless steel
- 844 KH** Measuring heads carbide tipped on both sides, carbide expanding pin
- 844 KS** Blind hole measuring heads hard chrome plated, expanding pin made of stainless steel

Accuracy

Deviation of linearity

- ≤ 2 % measuring ranges 0.47-1.55 mm
- ≤ 1 % measuring ranges 1.5-18.6 mm

Repeatability

- 1 μm manual measurement
- ≤ 0.5 μm measurement with Stand 844 Kst and Floating Holder 844 Ksts

Catalog no.	Measuring range mm	Number of meas. probes	Order no.*
844 K	0.47 - 0.97	6	4470000
	0.95 - 1.55	5	4470001
	1.5 - 4.2	10	4470002
	3.7 - 7.3	7	4470003**
	6.7 - 10.3	7	4470004**
	9.4 - 18.6	9	4470005**
844 KH	1.5 - 4.2	10	4471002
	3.7 - 7.3	7	4471003**
	6.7 - 10.3	7	4471004**
	9.4 - 18.6	9	4471005**
844 KS	1.5 - 4.2	10	4482163
	3.7 - 7.3	7	4482164**
	6.7 - 10.3	7	4482165**
	9.4 - 18.6	9	4482166**

Indicating Instruments

All indicating instruments that has a 8 mm mounting shank may be used. Recommended are:

Indicators	Readings	Order no.
Compramess 1004	5 μm	4333000
Millimess 1003	1 μm	4334000
Millimess 1003 XL	2 μm	4334001
Supramess 1002	0.5 μm	4335000
Extramess 2000	0.2 μm, 0.5 μm, 1 μm	4346000
Extramess 2001	0,2 μm, 0.5 μm, 1 μm	4346100
MarCator 1087 B	1 μm, 2 μm, 4 μm, 10 μm	4337062

* Excludes an indicating instrument

** Additionally includes measuring force spring 4470828 and disk 4470821

Digital Indicators see Chapter 5
Electrical Indicating Instruments see Chapter 7

Modular Unit System for 844 K Standard Measuring Probes

In addition complete Dial Bore Gages 844 K, modular units area available for assembly as required to suit an individual measuring task and or application.

Measuring Probe 844 Kk, Expander Pin, individual Ring Gage for 844 Ke

Nominal dimension mm	Measuring range mm	Measuring depth mm	Measuring probe hard chrome plated	Expanding pin steel	Measuring probe carbide tipped	Expander pin carbide	Ring gage	
0.50	0.47 - 0.53	1.25	4470586	4470801			4482300	
0.55	0.52 - 0.58	1.5	4470587				4482301	
0.60	0.57 - 0.67	1.7	4470588	4470802			4482302	
0.70	0.65 - 0.77	2.2	4470589				4482303	
0.80	0.75 - 0.87	2.55	4470590				4482304	
0.90	0.85 - 0.97	2.65	4470591				4482305	
1.00	0.95 - 1.15	10.5	4470592	4470803			4482306	
1.10	1.07 - 1.25	10.5	4470593				4482307	
1.20	1.17 - 1.35	10.5	4470594				4482308	
1.30	1.27 - 1.45	10.5	4470595				4482309	
1.40	1.37 - 1.55	10.5	4470596				4482310	
1.75	1.50 - 1.90	16	4470597				4470804	4471234
2.00	1.80 - 2.20	16	4470598	4471206	4482312			
2.25	2.05 - 2.45	16	4470599	4470805	4471813	4471819	4482313	
2.50	2.30 - 2.70	21	4470600				4482314	
2.75	2.55 - 2.95	21	4470601				4471814	4482315
3.00	2.80 - 3.20	21	4470602				4471208	4482316
3.25	3.05 - 3.45	21	4470603	4470806	4471815	4471200	4482317	
3.50	3.30 - 3.70	21	4470604				4471816	4482318
3.75	3.55 - 3.95	21	4470605				4471817	4482319
4.00	3.80 - 4.20	21	4470606				4471204	4482320
4.00	3.70 - 4.30	38	4470607	4470806	4471607	4471200	4482320	
4.50	4.20 - 4.80	38	4470608				4471608	4482321
5.00	4.70 - 5.30	38	4470609				4471609	4482322
5.50	5.20 - 5.80	38	4470610				4471610	4482323
6.00	5.70 - 6.30	38	4470611				4471611	4482324
6.50	6.20 - 6.80	38	4470612				4471612	4482325
7.00	6.70 - 7.30	38	4470613				4471613	4482326
7.50	7.20 - 7.80	38	4470615				4471615	4482327
8.00	7.70 - 8.30	38	4470616				4471616	4482328
8.50	8.20 - 8.80	45	4470617				4471617	4482329
9.00	8.70 - 9.30	45	4470618	4471618	4482330			
9.50	9.20 - 9.80	45	4470619	4471619	4482331			
10.00	9.70 - 10.30	45	4470620	4471620	4482332			
10.00	9.40 - 10.60	45	4470621	4470808	4471621	4471202	4482332	
11.00	10.40 - 11.60	45	4470622				4471622	4482333
12.00	11.40 - 12.60	45	4470623				4471623	4482334
13.00	12.40 - 13.60	45	4470624				4471624	4482335
14.00	13.40 - 14.60	45	4470625				4471625	4482336
15.00	14.40 - 15.60	45	4470626				4471626	4482337
16.00	15.40 - 16.60	80	4470627				4471627	4482338
17.00	16.40 - 17.60	80	4470628				4471628	4482339
18.00	17.40 - 18.60	80	4470629				4471629	4482340

Nominal dimension
mm

L
mm

H 1
mm

0.50	19.50	0.25
0.55	19.50	0.27
0.60	19.50	0.29
0.70	19.50	0.31
0.80	19.50	0.33
0.90	19.50	0.35
1.00	19.50	0.60
1.75	25.30	0.90
2.50	30.60	1.20
4.00	47.30	2.00
10.00	48.50	3.30

Minimum measurement height

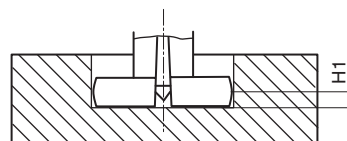

Modular Unit System for 844 KS Blind Hole Measuring Probes

In addition to complete Dial Bore Gages 844 KS, modular units are available for assembly as required to suit a individual measuring task and or application.

Blind Hole Measuring Probe 844 Kk, Blind Hole Expander Pin

Nominal dimension	Measuring range	Measuring depth	Blind hole measuring probe hard chrome plated	Blind hole expander pin steel
mm	mm	mm		
1.75	1.50 - 1.90	16	4482228	4482176
2.00	1.80 - 2.20	16	4482229	
2.25	2.05 - 2.45	16	4482230	
2.50	2.30 - 2.70	21	4470301	
2.75	2.55 - 2.95	21	4482227	
3.00	2.80 - 3.20	21	4482178	
3.25	3.05 - 3.45	21	4482179	4482177
3.50	3.30 - 3.70	21	4470300	
3.75	3.55 - 3.95	21	4482188	
4.00	3.80 - 4.20	21	4482180	
4.00	3.70 - 4.30	38	4482057	
4.50	4.20 - 4.80	38	4482162	
5.00	4.70 - 5.30	38	4482056	4482028
5.50	5.20 - 5.80	38	4470953	
6.00	5.70 - 6.30	38	4482140	
6.50	6.20 - 6.80	38	4482055	
7.00	6.70 - 7.30	38	4482108	
7.50	7.20 - 7.80	38	4482204	
8.00	7.70 - 8.30	38	4482054	4482192
8.50	8.20 - 8.80	45	4482206	
9.00	8.70 - 9.30	45	4482170	
9.50	9.20 - 9.80	45	4482182	
10.00	9.70 - 10.30	45	4470375	
10.00	9.40 - 10.60	45	4482205	
11.00	10.40 - 11.60	45	4482042	4482112
12.00	11.40 - 12.60	45	4482112	
13.00	12.40 - 13.60	45	4482102	
14.00	13.40 - 14.60	45	4482181	
15.00	14.40 - 15.60	45	4482202	
16.00	15.40 - 16.60	80	4482021	
17.00	16.40 - 17.60	80	4482203	4482113
18.00	17.40 - 18.60	80	4482113	

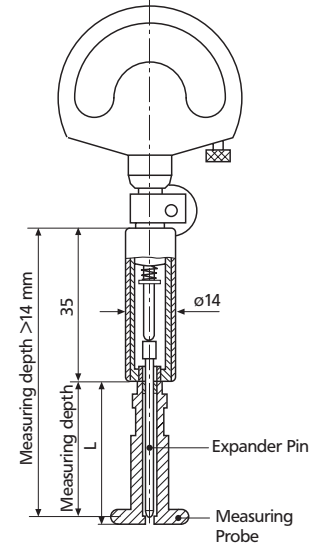

844 Kk

Minimum measurement height

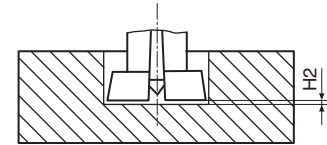

Nominal dimension	L	H/2
mm	mm	mm
0.50	19.50	
0.55	19.50	
0.60	19.50	
0.70	19.50	
0.80	19.50	
0.90	19.50	
1.00	1.40	19.50
1.75	2.25	25.30
2.50	4.00	30.60
4.00	10.00	47.30
10.00	18.00	48.50
		1.00

Ring Gage Sets 844 Ke

For setting Dial Bore Gages 844 K, 844 KH and 844 KS. Supplied in sets to match the measuring ranges of these instruments. Can be stored in the wooden case of the bore gages.

Diameter tolerance $\pm 1 \mu\text{m}$

Ring Gages 844 Ke are only available with the diameters shown in the table.

For all other dimensions, Ring Gages 355 E with dimensions as per DIN 2250 and with actual deviation engraved are available.

For Meas. range	Diameter	Order no.
mm	mm	
0.47 - 0.97	0.5/0.55/0.6/0.7/0.8/0.9	4470160
0.95 - 1.55	1/1.1/1.2/1.3/1.4	4470161
1.5 - 4.2	1.75/2/2.25/2.5/2.75/ 3/3.25/3.5/3.75/4	4470162
3.7 - 7.3	4/4.5/5/5.5/6/6.5/7	4470163
6.7 - 10.3	7/7.5/8/8.5/9/9.5/10	4470164
9.4 - 18.6	10/11/12/13/14/15/ 16/17/18	4470165

Modular Unit System for 844 K

Holder 844 Kg

With locking clamp for an indicating instrument and a connecting thread for a **Measuring Head 844 Kk**. Heat insulated handle

Order no. 4470851

Extensions 844 Kv

For extra-deep bores. Screws in between Holder 844 Kg and Measuring Head 844 Kk for measuring range 10-18 mm. Length 64 mm, \varnothing 8 mm,

Order no. 4470070

Right Angle Attachment 844 Kw

For measuring bores which are difficult to reach, e.g. in tight spaces, on machine tools or when work piece bores are inconveniently located. For screwing in between Holder 844 Kg and Measuring Head 844 Kk

Order no. 4470110

Lifter 954

Facilitates insertion of measuring probe in bore by lifting measuring spindle of dial comparator.

Order no. 4372030

Depth Stop 844 Kt

For checking diameter of bores at prescribed depth. Only to be used with Extension 844 Kv.

Order no. 4470115

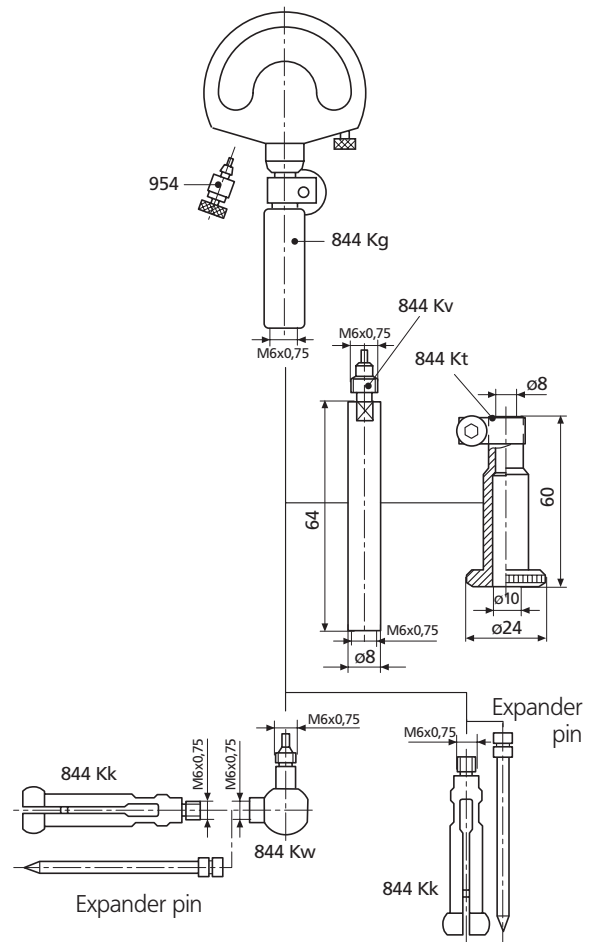

Measuring Probes for Special Applications

For measurement of blind holes, diameters of recesses, distances between plane-parallel surfaces, etc. special models of measuring probes are available on request.

1. Measurement of the diameter of recesses

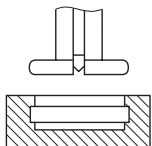

2. Measurement of plane-parallel surfaces

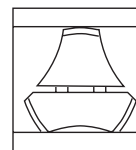

3. Measurement of polygon bores

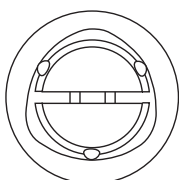

4. Measurement of inside serrations, see 844 Z Page 9-46

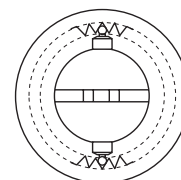

Accessories

Stand 844 Kst



Floating Holder 844 Ksts



Features

For quick checks of bores in small work pieces. Hardened table plate can be raised with lever, thus moving test piece into position. Plate can be clamped at any height for checking eccentricity. Particularly suited to use with digital indicators, where appropriate in conjunction with data printers or computer equipment, in cases where the determination of the reversal point is inappropriate.

Table dia.	58 mm
Throat depth of arm	45 mm
Table stroke	30 mm
Max. work piece height	ca. 100 mm

Order no. 4470100

Features

For use in conjunction with Stand 844 Kst. Enables measuring probe to find common axis of bore and measuring instrument quickly and easily on insertion into hole, thus providing optimum measuring speed and high accuracy. Particularly suitable for small diameters, as measuring confidence is considerably enhanced.

Order no. 4470105

Angle Stop 844 Ka

Facilitates positioning of cylindrical work pieces under measuring instrument. For clamping to Stand 844 Kst.

Order no. 4470120

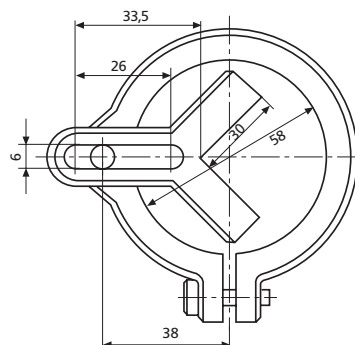

Adjustable Bore Gages 1280 P

Superior Accuracy for Production and Inspection.



1282P-3W2 and 1280P-1W1

Features

- Rugged construction for long life and low maintenance: Stainless steel gaging head, one piece centralizing yoke with replaceable tungsten carbide balls.
- Heavy duty housing protects Indicator.
- Flow-through design makes Series 1280P Bore Gages swish clean, no disassembly required.
- Outstanding stability: Holds mastered value.
- Furnished with either Dial Indicator or Maxµm^{III} Digital Electronic Indicator.
- Digital bore gages with output are provided with Maxµm^{III} Indicators. The Dynamic memory of the Maxµm^{III} greatly simplifies operation and assures repeatable readings with a single sweep of the diameter being measured.
- Output available for Statistical Quality Control requirements.

Technical Data

With Dial Indicator

Range of Sensitive Contact: 0.63 mm / **.025"**,
0.002 mm / **.0001"** grad.

With Maxµm^{III} Indicators

Range of Sensitive Contact: 0.39 mm / **.020"**.
Resolution: 0.001 mm / **.00005"** resolution,
0.001 mm / **.001"** grad.

If gage capacity is 25 mm / 1" or greater, the Maxµm^{III} Indicator is covered with a cast aluminum protective housing. If under 25 mm / 1" capacity, the protective housing is not normally furnished.

With Dial Indicator	With Digital Output	Capacity mm/ <i>inch</i>	Gaging Depth mm/ <i>inch</i>	End of Head to Contact mm/ <i>inch</i>
1280P-1W1	1282P-1W1	12 - 25 / .50 - 1"	76 / 3"	2.77 / .11"
1280P-2W2	1282P-2W2	25 - 50 / 1 - 2"	152 / 6"	4.37 / .17"
1280P-3W2	1282P-3W2	50 - 203 / 2 - 8"	152 / 6"	7.92 / .31"
1280P-1W2	1282P-1W2	12 - 25 / .50 - 1"	152 / 6"	2.77 / .11"
1280P-2W3	1282P-2W3	25 - 50 / 1 - 2"	305 / 12"	4.37 / .17"
1280P-3W3	1282P-3W3	50 - 203 / 2 - 8"	305 / 12"	7.92 / .31"

See matrix on next page.

Note: Model numbers do not include extensions.

Series 1280P Adjustable Bore Gages are normally furnished with adjusting wrenches. Reference contacts for particular measurement sizes must be specified separately (see table on following page). If not specified, T.C. contacts will be furnished. For alternate gaging depths, contact materials, and other modifications are available.

Example: **1282P-3MW3** with **PT-156** and **EX-224** specifies an Adjustable Bore Gage with tungsten carbide reference contact and an extension to cover the range from 75 mm / 3" to 89 mm / 3.5".

The Gage is furnished with a Metric Maxµm^{III} Indicator, **2033119** (which has selectable resolution, units and includes Digital Output).

Adjustable Bore Gages 1280 P

Ordering Information

To order the correct bore gage to suit your measurement application, start with the base Model Number: **128XP-XXXX** and substitute the X with the appropriate number or letter from the boxes below:

128 X P - X X X X

Indicator

- 0 – Dial Indicator
- 2 – Maxµm®/III with Output

Capacity

- 1 – 12.50 - 25 mm / **.50 - 1"** gaging depth to 305 mm / **12"**
- 2 – 25 - 50 mm / **1 - 2"** gaging depth to 610 mm / **24"**
- 3 – 50 - 200 mm / **2 - 8"** gaging depth to 1220 mm / **48"**

Units

- Omit for Inch
- M** – Metric

Configuration

- W** – Gage only
- S** – Complete kit with steel contacts*
- T** – Complete kit with T.C. contacts*

* Each kit is complete with components needed for capacity ranging from 12.70 - 203 mm / .50 - 8". A fitted case is furnished for all models with a gaging depth 150 mm / 6" or under. It contains a Dial or Maxµm/III Indicator with each tube assembly and all contacts, extensions, extenders, locknuts and necessary wrenches.

Gaging Depth

- 1 – 76 mm / **3"**
- 2 – 150 mm / **6"**
- 3 – 300 mm / **12"**
- 4 – 450 mm / **18"**
- 5 – 600 mm / **24"**
- 6 – 760 mm / **30"**
- 7 – 910 mm / **36"**
- 8 – 1220 mm / **48"**

Example: If you chose **1282P-3S5** as your model number, you would have chosen an Inside Diameter gage with Maxµm/III Indicator, 50 - 200 mm / 2 - 8" capacity, inch units, having a complete kit with steel contacts and a gaging depth of 600 mm / 24". Metric equivalent Model would be: **1282P-3MS5**.

Handles / Housing

All 1280P gages have a removable handle as a part of the Indicator Housing.

All 1282P gages can be equipped with a handle which projects at 90° to the gage housing.

1282P gages with capacity 12-25 mm / .50-1" are not normally furnished with a protective housing. Handles and Housings may be ordered separately.

For Handles order **HA-88** with **AT-124** Adaptor. For Housings order **EHG-1198**.

Gaging Extensions

Specify the Reference Contact Gaging Extensions required from the table below. For all diameters below 50 mm / 2" the Reference Contact is integral with each Extension. For diameters over 50 mm / 2" the Reference Contact is separate and interchangeable among Extension Sets.



1282P-1W1
(Output Cable not included)

Technical Data

Diameter to be measured mm/ <i>inch</i>	Extension Required		Used on Gage Model Numbers
	Carbide	Steel	
12 - 16 / .50 - .625"	PT-562	PT-558	1280P-1xxx
16 - 19 / .625 - .75"	PT-567	PT-559	
19 - 22 / .75 - .875"	PT-568	PT-560	1282P-1xxx
22 - 25 / .875 - 1"	PT-557	PT-561	
25 - 32 / 1 - 1.25"	PT-554	PT-555	1280P-2xxx
32 - 38 / 1.25 - 1.50"	PT-553	PT-556	
38 - 45 / 1.50 - 1.75"	PT-552	PT-569	1282P-2xxx
45 - 50 / 1.75 - 2"	PT-550	PT-551	

For the gaging diameters listed below, select one Contact Point and at least one Extension Set.

Contact Point:	Extension Required	Used on Gage Models
Carbide	PT-156	1280P-3XXX
Steel	PT-2224	1282P-3XXX

Extension Sets:	Diameter to be Measured mm/ <i>inch</i>	Extension Sets	Used on Gage Models
	50 - 64 / 2 - 2.5"	EX-222	
	64 - 76 / 2.5 - 3"	EX-223	
	76 - 89 / 3 - 3.5"	EX-224	1280P-3XXX
	89 - 100 / 3.5 - 4"	EX-225	
	100 - 127 / 4 - 5"	EX-223 with EX-226	1282P-3XXX
	127 - 152 / 5 - 6"	EX-225 with EX-226	
	152 - 178 / 6 - 7"	EX-223 with EX-228	
	178 - 200 / 7 - 8"	EX-225 with EX-228	

Self-Centering Dial Bore Gages 844 N / 844 NH Intramess

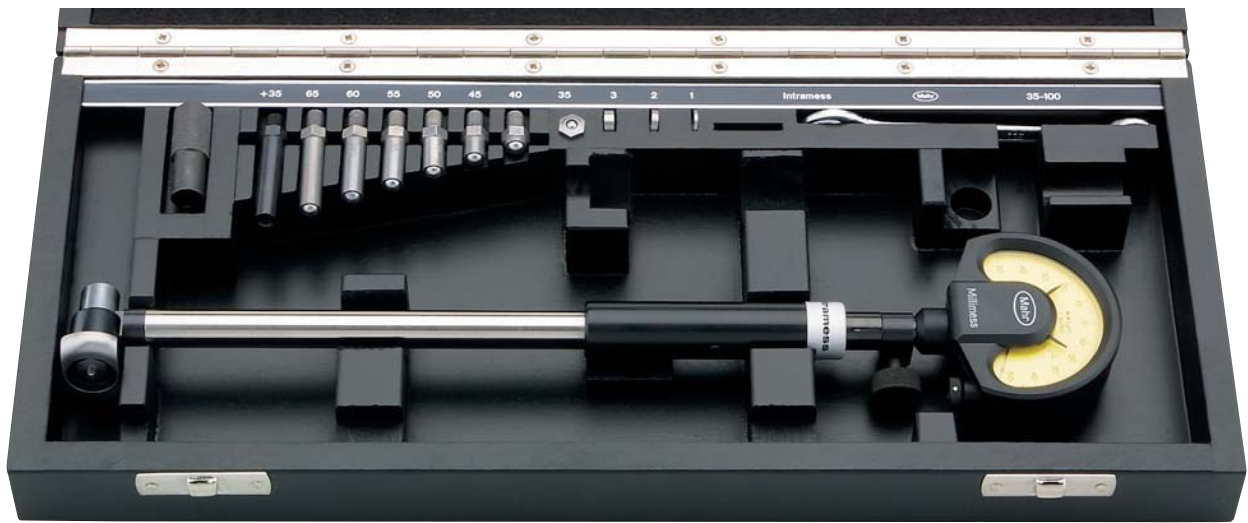

Features

- Measuring the diameter, roundness and conical form of a bore as well as the distances of plane-parallel surfaces
- Measuring head consists of a carbide-tipped moving anvil and an interchangeable stationary anvil which has a hardened steel ball; alternatively a carbide ball is available
- Transmission lever system transfers movement of the movable anvil to indicating instrument
- The broad centering bridge ensures automatic centering in the bore
- Insensitive to temperature due to both the shank and transfer rod being made from heat resistant **Invar steel**
- Highly resistant to wear and tear due to the carbide tipped moving anvil
- Constant measuring force due to built-in spring thus eliminating user influence
- Universally applicable and extremely versatile as every instrument spans a broad measuring range, within this range it is quick and easy to adjust to any size
- Measuring head, holder, extensions, right-angle attachments and depth stops are all part of this extensive modular system
- Supplied with: Holder, measuring head, stationary anvil, wooden case, excludes an indicating instrument

The comparison between Invar and Standard steel

Invar steel has a particularly low expansion coefficient and thus makes the instrument totally insensitive to any kind of heat. Body heat from the user, increases in ambient temperature have no influence on the measuring results.

The graph on the right compares the Invar steel version to a standard type. Both gages were hand-held and thus influenced by body heat. The deviation when using Invar steel is negligible.

Change in length due to heat

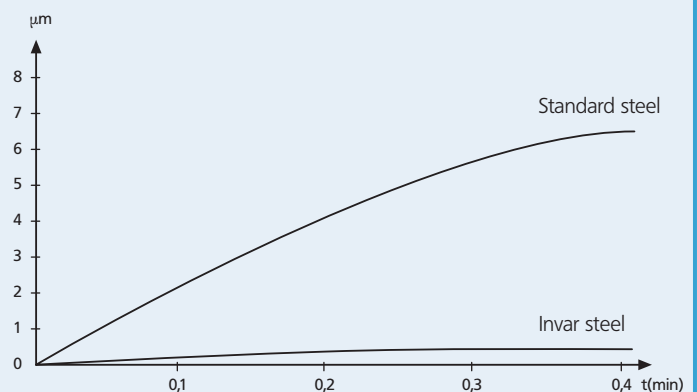

Technical Data Daten

Measuring range		Error limit	Repeatability	Hysteresis	Order no* 844 N	Order no* 844 NH
mm	(inch)	G_e μm	f_w μm	f_u μm		
18 - 50	(.7 - 2")	2	0.5	2.5	4474000	4475000
35 - 100	(1.4 - 4")	2	0.5	2.5	4474001	4475001
100 - 250	(4 - 10")	2	0.5	2.5	4474002	4475002
250 - 400	(10 - 16")	3	1.5	3.5	4474003	4475003
400 - 800	(16 - 32")	3	1.5	3.5	4474004	4475004
250 - 800	(10 - 32")	3	1.5	3.5	4474005	4475005

* Excludes indicating instrument

Complete Instrument

844 N Carbide-tipped moving anvil;
stationary anvil with steel ball

844 NH Moving anvil **and** stationary anvil are carbide-tipped

Measuring range	a	b	c	d	e
mm (inch)					
18 - 50 (.7 - 2")	5.35	8	115	63	22
35 - 100 (1.4 - 4")	8.5	12	148	80	22
100 - 250 (4 - 10")	11.5	18	230	100	25
250 - 400 (10 - 16")	16	24	366	110	28
400 - 800 (16 - 32")	17.5	24	366	110	28

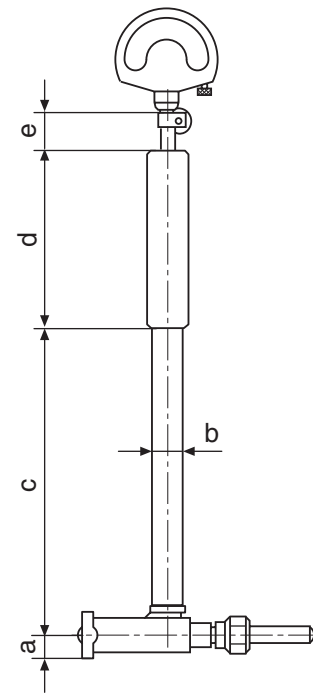

Indicating Instruments

All indicating instruments that has a 8 mm mounting shank may be used. Recommended are:

Indicator	Readings mm / inch	Order no. mm / inch
Compramess 1004 / 1004 Z	5 μm / .0001"	4333000/4333900
Millimess 1003 / 1003 Z	1 μm / .00005"	4334000/4334900
Millimess 1003 XL	2 μm	4334001
Supramess 1002 / 1002 Z	0.5 μm / .00002"	4335000/4335900
Extramess 2001	0.2 μm / .00001"	
	0.5 μm / .00002"	4346100*
	1 μm / .00005"	
$\mu\text{Max}\mu\text{m}$.0005mm / .00002"	EDI-20302**
Marcator 1087 B	.001mm / .00005"	
	.002mm / .0001"	4337062
	.004mm / .0005"	
	.010mm / .001"	



2001



1003

Digital Indicators see Chapter 5

Electrical Indicating Instruments see Chapter 7

* 230 V, for 115 V please refer to page 6-5

** requires contact 4360045

Accessories to set and adjust Dial Bore Gages

1. Setting Device

Uses standard gage blocks for setting any bore diameter and any tolerance. Replaces ring gages and is universally applicable.

2. Ring Gage 355 E

Special wear-resistant gage steel. Hardened and lapped. With actual deviation engraved

Dimensions: DIN 2250, type C
 Manufacturing tolerance: DIN 2250
 Available diameters: 0.5 - 200 mm



355 E

Components

Measuring Jaw 844 em

Measuring range mm	Dimensions (inch)	Dimensions mm/inch	Order no.
18 - 800	(.7 - 32")	60 x 9.5 x 9 / 2.36 x .37 x .35"	4470095

Setting Bridge 844 Neb

Measuring range mm	Width (inch)	Width mm/inch	Height mm/inch	Order no.
18 - 250	(.7 - 10")	70 / 2.75"	12 / .47"	4474080
18 - 400	(.7 - 16")	165 / 6.49"	17 / .67"	4474081
18 - 800	(.7 - 32")	320 / 12.59"	20 / .78"	4474082

Gage Block Holder 420 h

Clamping range mm	Clamping range (inch)	Order no.
0 - 70	(0 - 2.75")	4800120
0 - 120	(0 - 4.72")	4800121
100 - 220	(4 - 8.66")	4800122
100 - 420	(4 - 16.53")	4800123
400 - 820	(16 - 32.28")	4800124

Stand 844 ef

For mounting setting device up to 420 mm

Order no. 4470098

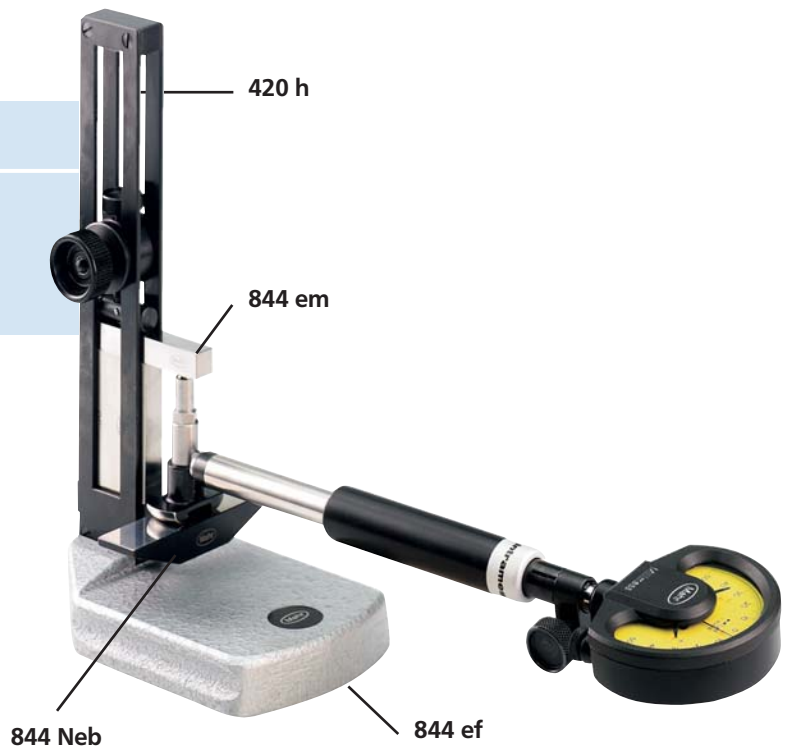

Modular Unit System 844 N

In addition to complete Dial Bore Gages 844 N, modular units can also be compiled as required to suit a individual measuring task and or application.

Measuring Head 844 Nk, steel

Measuring Head 844 NHk, carbide

With built-in lever transmission system, carbide-tipped anvil and extra-wide centering bridge. With interchangeable stationary anvil. Threaded connection for Holders 844 Ng and 844 Ngk.

Measuring range mm	(inch)	Order no. 844 Nk	Order no. 844 NHk
18 - 50	(.7 - 2")	4474151	4474156
35 - 100	(1.37 - 4")	4474152	4474157
100 - 250	(4 - 10")	4474153	4474158
250 - 400	(10 - 16")	4474154	4474159
400 - 800	(16 - 32")	4474155	4474160

Extension Set 844 Nes

For extending range of Measuring Head 844 Nk/NHk from 250-400 mm to 800 mm. Consists of additional centering bridge and two extensions.

Order no.: 4474010

Holder 844 Ng

Shank and transfer rod made of heat-resistant Invar steel. With a locking clamp for indicator.

For meas. range mm (inch)	L mm/inch	d1 mm/inch	d2 mm/inch	Order no.
18 - 50 (.7 - 2")	200/ 8"	14/ .6"	8/ .3"	4474040
35 - 100 (1.37 - 4")	250/ 10"	18/ .7"	12/ .5"	4474041
100 - 250 (4 - 10")	350/ 14"	26/ 1.0"	18/ .7"	4474042
250 - 800 (10 - 32")	500/ 20"	30/ 1.2"	24/ .9"	4474043

Short Holder 844 Ngk

Shank and transfer rod made of heat-resistant Invar steel. With a locking clamp for an indicator.

For meas. range mm (inch)	L mm/inch	d1 mm/inch	d2 mm/inch	Order no.
18 - 50 (.7 - 2")	120/ 5"	14/ .6"	8/ .3"	4474050
35 - 100 (1.37 - 4")	120/ 5"	18/ .7"	12/ .5"	4474051
100 - 250 (4 - 10")	150/ 6"	26/ 1.0"	18/ .7"	4474052
250 - 800 (10 - 32")	250/ 10"	30/ 1.2"	24/ .9"	4474053

Right Angle Attachment 844 Nw

For measuring difficult to reach bores, e.g. in tight spaces, inconveniently located or on machine tools. For screwing in between 844 Ng or 844 Ngk and 844 Nk/NHk.

For meas. ranges mm	(inch)	Length* L mm/inch	Bore depth mm/inch	Order no.
18 - 50	(.7 - 2")	66/2.6"	45/1.8"	4474070
35 - 100	(1.37 - 4")	80/3.1"	55/2.2"	4474071
100 - 250	(4 - 10")	105/4.1"	70/2.8"	4474072

* With measuring heads 844 Nk/NHk

Extension 844 Nv

For extra deep bores. For screwing in between 844 Ng and 844 Nk/NHk. Shank and transfer rod made of Invar steel.

For instruments mm	(inch)	Length L (mm/inch)	Order no.
18 - 50	(.7 - 2")	250 / 9.8"	4474066
35 - 100	(1.37 - 4")	250 / 9.8"	4474060
100 - 250	(4 - 10")	250 / 9.8"	4474061
		500 / 19.7"	4474062
250 - 800	(10 - 32")	250 / 9.8"	4474063
		500 / 19.7"	4474064

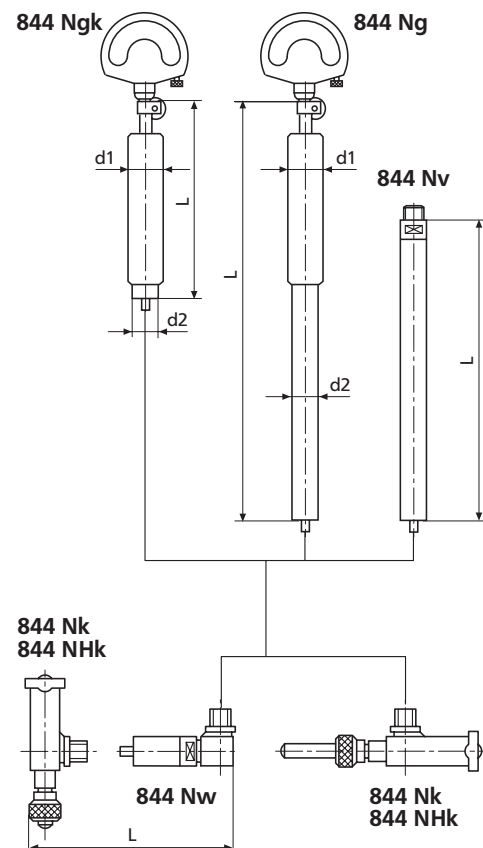

Dial Bore Gage for Internal Serrations 844 Z



Dial Bore Gage 844 Z
 Diametrical two ball measurement "M_{dk}" from 3.5 - 333 mm

Modular Unit Parts 844 Kk
 "M_{dk}" from 3.5 - 26.1 mm
 (see table below)

Modular Unit Parts 844 Z
 "M_{dk}" 26 - 333 mm (see table on opposite page)

Modular Unit Parts:

Diametrical two ball measurement „M_{dk}“ from 3.5 - 26.1 mm

Ball dimen. M _{dk} (mm)	Order no. ball dia. 1-5 graduation 0.5	Ball dia. according to table	Order no. ball dia. 7.5-10 graduation 0.5	Expander pin Steel
3.5 - 4.1	4482450	4482550		4470806
4.0 - 4.6	4482451	4482551		
4.5 - 5.1	4482452	4482552		
5.0 - 5.6	4482453	4482553		
5.5 - 6.1	4482454	4482554		
6.0 - 6.6	4482455	4482555		
6.5 - 7.1	4482456	4482556		
7.0 - 7.6	4482457	4482557		
7.5 - 8.1	4482458	4482558		
8.0 - 8.6	4482459	4482559		
8.5 - 9.1	4482460	4482560		
9.0 - 9.6	4482461	4482561		
9.3 - 10.6	4482462	4482562	4482662	4470808
10.3 - 11.6	4482463	4482563	4482663	
11.3 - 12.6	4482464	4482564	4482664	
12.3 - 13.6	4482465	4482565	4482665	
13.3 - 14.6	4482466	4482566	4482666	
14.5 - 16.1	4482467	4482567	4482667	
15.5 - 17.1	4482468	4482568	4482668	
16.5 - 18.1	4482469	4482569	4482669	
17.5 - 19.1	4482470	4482570	4482670	
18.5 - 20.1	4482471	4482571	4482671	
19.5 - 21.1	4482472	4482572	4482672	
20.5 - 22.1	4482473	4482573	4482673	
21.5 - 23.1	4482474	4482574	4482674	
22.5 - 24.1	4482475	4482575	4482675	
23.5 - 25.1	4482476	4482576	4482676	
24.5 - 26.1	4482477	4482577	4482677	

Table (Sizes in mm)

0.500 - 0.551 - 0.620 - 0.623 - 0.630 - 0.722 - 0.862 - 0.895 - 0.965 - 1.100 - 1.118 - 1.125 - 1.250
 1.350 - 1.372 - 1.385 - 1.524 - 1.540 - 1.600 - 1.650 - 1.700 - 1.750 - 1.782 - 1.800 - 1.829 - 1.900
 2.032 - 2.250 - 2.284 - 2.386 - 2.438 - 2.667 - 2.704 - 2.713 - 2.721 - 2.743 - 2.750 - 3.048 - 3.250
 3.400 - 3.658 - 4.835 - 5.250 - 5.486 - 5.500 - 6.000 - 6.096 - 6.350 - 6.500 - 7.000

Features

- For diametrical two ball measurement M_{dk}, to obtain the pitch diameter and conical form of internal gears in any position and at any depth
- For ball dimensions from 3.5 to 26.1 mm use the 844 Kk with carbide ball anvils and in conjunction with an expander pin
- For ball dimensions >26 mm the measuring heads 844 z1 or 844 z2 with the appropriate modular units are to be employed
- Maximum wear resistance due to carbide ball anvils
- Constant measuring force due to built-in spring thus eliminating user influence
- Anvils, measuring heads, holder, spacer (intermediate piece) and depth extensions form a very comprehensive modular system which can rapidly be converted to measure further gear sizes

Lifting Knob 954

enables the dial bore gage to gently guided into the serration. The measuring spindle of the indicating instrument can also be lifted.

Order no. 4372030

Holder 844 Kg

with a clamping device for the indicating instrument. The mounting bore diameter 8 mm

Order no. 4470851

Extension 844 Kv

for measuring in depth bores; length 64 mm

Order no. 4470070

844 Kk Anvil

for internal serrations. ball dimension „M_{dk}“ from

3.5 - 26.1 mm

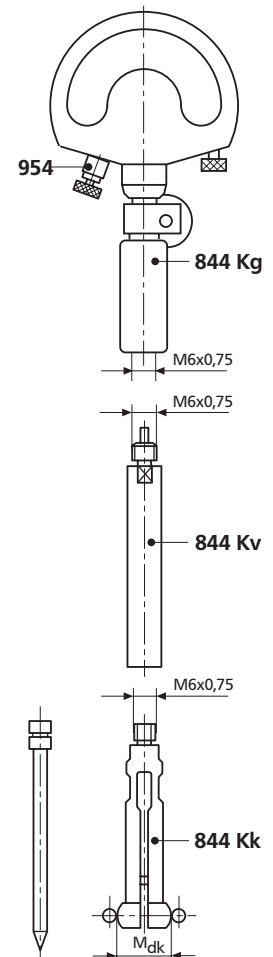

Modular Unit Parts

Diametrical two ball measurement from M_{dk} 26-333 mm

Measuring Heads

844 z1, for M_{dk} 26 - 130,5 mm

844 z2, for M_{dk} 48.5 - 333 mm

Order no.

4485000

4485001

Floating Ball Anvils with carbide ball

	Grad. (mm)	Ball dia. mm	
844 z3 Meas. range 3 mm, for Meas. Head 844 z1	0.5	1.0 - 5.0	4488300
		acc. to table	4488301
	0.5	7.5 - 10	4488302
844 z4 Meas. range 3 mm, for Meas. Head 844 z2	0.5	1.0 - 5.0	4488310
		acc. to table	4488311
	0.5	7.5 - 10	4488312

Ball Anvils with carbide ball

844 z5 , Length 2.5 mm	0.5	1.0 - 5.0	4488320
		acc. to table	4488321
	0.5	7.5 - 10	4488322
844 z6 , Length 5.0 mm	0.5	1.0 - 5.0	4488330
		acc. to table	4488331
	0.5	7.5 - 10	4488332
844 z7 , Length 7.5 mm	0.5	1.0 - 5.0	4488340
		acc. to table	4488341
	0.5	7.5 - 10	4488342
844 z8 , Length 10.0 mm	0.5	1.0 - 5.0	4488350
		acc. to table	4488351
	0.5	7.5 - 10	4488352
844 z15 , Length adjustable from 24-34 mm	0.5	1.0 - 5.0	4488360
		acc. to table	4488361
	0.5	7.5 - 10	4488362

Spacer (intermediate piece)

	Length (mm)	
844 z9	10	4486501
844 z10	20	4486502
844 z11	40	4486503
844 z12	80	4486504
844 z13	100 *	4486505

Wooden case

4485013

* Only for 844 z2

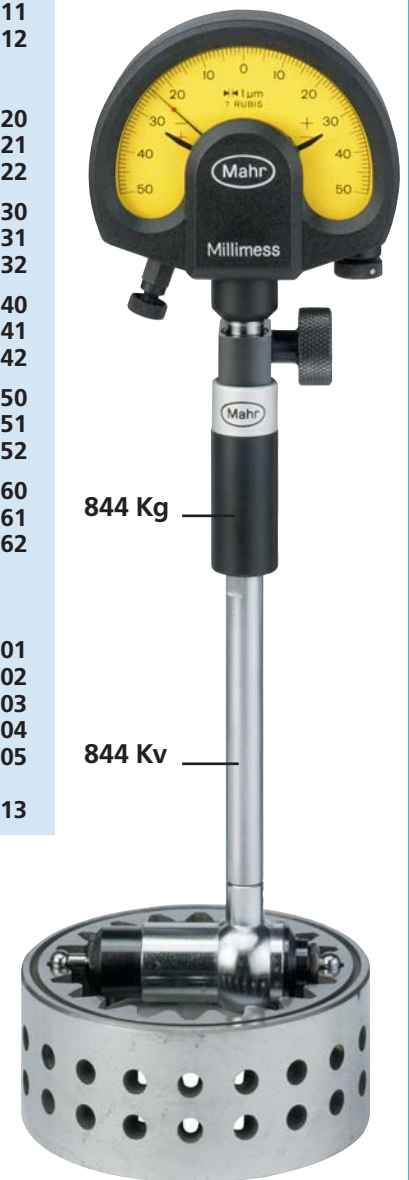
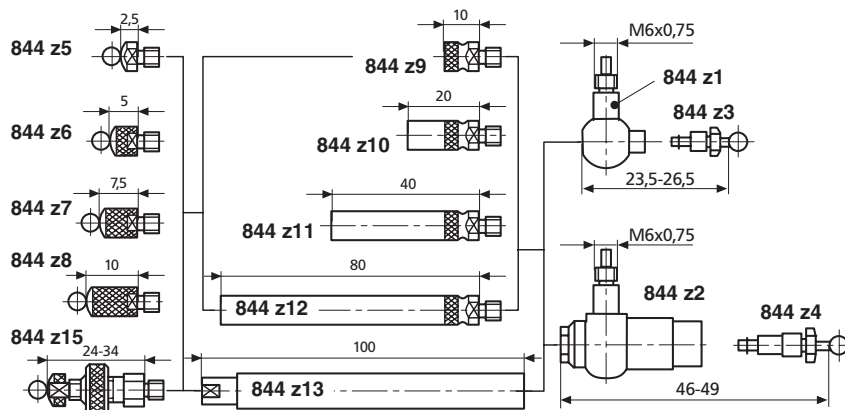

Dial Bore Gage for Internal Serrations 844 Z

Selecting Modular Unit Parts Measuring Head 844 z1 and Floating Ball Anvil 844 z3

M _{dk} in mm	844 z5	844 z6	844 z7	844 z8	844 z15	844 z9	844 z10	844 z11	844 z12	844 z13
26.0 - 29.0	x									
28.5 - 31.5		x								
31.0 - 34.0			x							
33.5 - 36.5				x						
36.0 - 39.0	x					x				
38.5 - 41.5		x				x				
41.0 - 44.0			x			x				
43.5 - 46.5				x		x				
46.0 - 49.0	x						x			
47.5 - 60.5					x					
48.5 - 51.5		x					x			
51.0 - 54.0			x				x			
53.5 - 56.5				x			x			
56.0 - 59.0	x					x	x			
57.5 - 70.5					x	x				
58.5 - 61.5		x				x	x			
61.0 - 64.0			x			x	x			
63.5 - 66.5				x		x	x			
66.0 - 69.0	x							x		
67.5 - 80.5					x		x			
68.5 - 71.5		x						x		
71.0 - 74.0			x					x		
73.5 - 76.5				x				x		
76.0 - 79.0	x					x		x		
77.5 - 90.5					x	x	x			
78.5 - 81.5		x				x		x		
81.0 - 84.0			x			x		x		
83.5 - 86.5				x		x		x		
86.0 - 89.0	x						x	x		
87.5 - 100.5					x			x		
88.5 - 91.5		x					x	x		
91.0 - 94.0			x				x	x		
93.5 - 96.5				x			x	x		
96.0 - 99.0	x					x	x	x		
97.5 - 110.5					x		x	x		
98.5 - 101.5		x				x	x	x		
101.0 - 104.0			x			x	x	x		
103.5 - 106.5				x		x	x	x		
107.5 - 120.5					x		x	x		
117.5 - 130.5					x		x	x		

Example:

Diametrical two ball meas. M_{dk} 73.0 mm
Ball dia. 5.486 mm

When placing an order please quote the ball diameter of the modular unit system for 844 z3 - 844 z8, as well as 844 z15. On the basis of the above specified example above result several combinations that are possible to choice from is dependent upon the work piece. For further details please refer to the illustration on Page 9-43.

The measuring application can be solved with either one of the following 4 versions:

Type	Description	Ball dia. mm	Length mm	Order no.
Version 1				
844 z1	Meas. Head		23.5-26.5	4485000
844 z3	Floating Ball Anvil	5.486		4488301
844 z7	Ball Anvil	5.486	7.5	4488341
844 z11	Spacer		40.0	4486503
Meas. range			71.0-74.0	
Version 2				
844 z1	Meas. Head		23.5-26.5	4485000
844 z3	Floating Ball Anvil	5.486		4488301
844 z15	Ball Anvil	5.486	24.0-34.0	4488361
844 z10	Spacer		20.0	4486502
Meas. range			67.5-80.5	
Version 3				
844 z2	Meas. Head		46.0-49.0	4485001
844 z4	Floating Ball Anvil	5.486		4488311
844 z6	Ball Anvil	5.486	5.0	4488331
844 z10	Spacer		20.0	4486502
Meas. range			71.0-74.0	
Version 4				
844 z2	Meas. Head		46.0-49.0	4485001
844 z4	Floating Ball Anvil	5.486		4488311
844 z15	Ball Anvil	5.486	24.0-34.0	4488361
Meas. range			70.0-83.0	

Determination of setting values

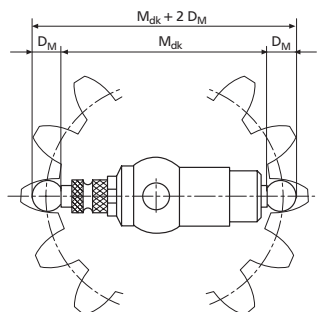

D_M = Ball diameter of the ball anvil

M_{dk} = Diametrical two ball measurement

$M_{dk} + 2 D_M$ = Setting value (length of the gage block required for setting)

Indicating Instruments

All indicating instruments that has a 8 mm mounting shank may be used. Recommended are:

Dial Comparator	Readings mm / inch	Order no. mm / inch
Compress 1004/1004 Z	5 µm / .0001"	4333000/4333900
Millimes 1003/1003 Z	1 µm / .00005"	4334000/4334900

Digital Indicators see Chapter 5
Electrical Indicating Instruments see Chapter 7

DO YOU HAVE DIVERSE MEASURING TASKS? MULTIMAR MASTERS THEM WITH FLYING COLORS.



The latest information on MULTIMAR products can be found on our website:
www.mahr.com, WebCode 10281

▶ | Regardless of whether gears, threads, cones or grooves are to be measured; the versatility of Multimar Universal Measuring Instruments combined with a broad range of accessories ensures a perfect solution for nearly all your internal and external measuring requirements.



▶ | Multimar. Universal Measuring Instruments

Multimar 25 ES

Digital Universal Caliper

10- 2

Multimar 844 T

Universal Measuring Instrument for Comparison Measurements

10- 4

Accessories for Multimar 25 ES / 844 T

10- 6

Multimar 36 B

Indicator Gage for Internal (I.D.) and External (O.D.) Measurements

10-21

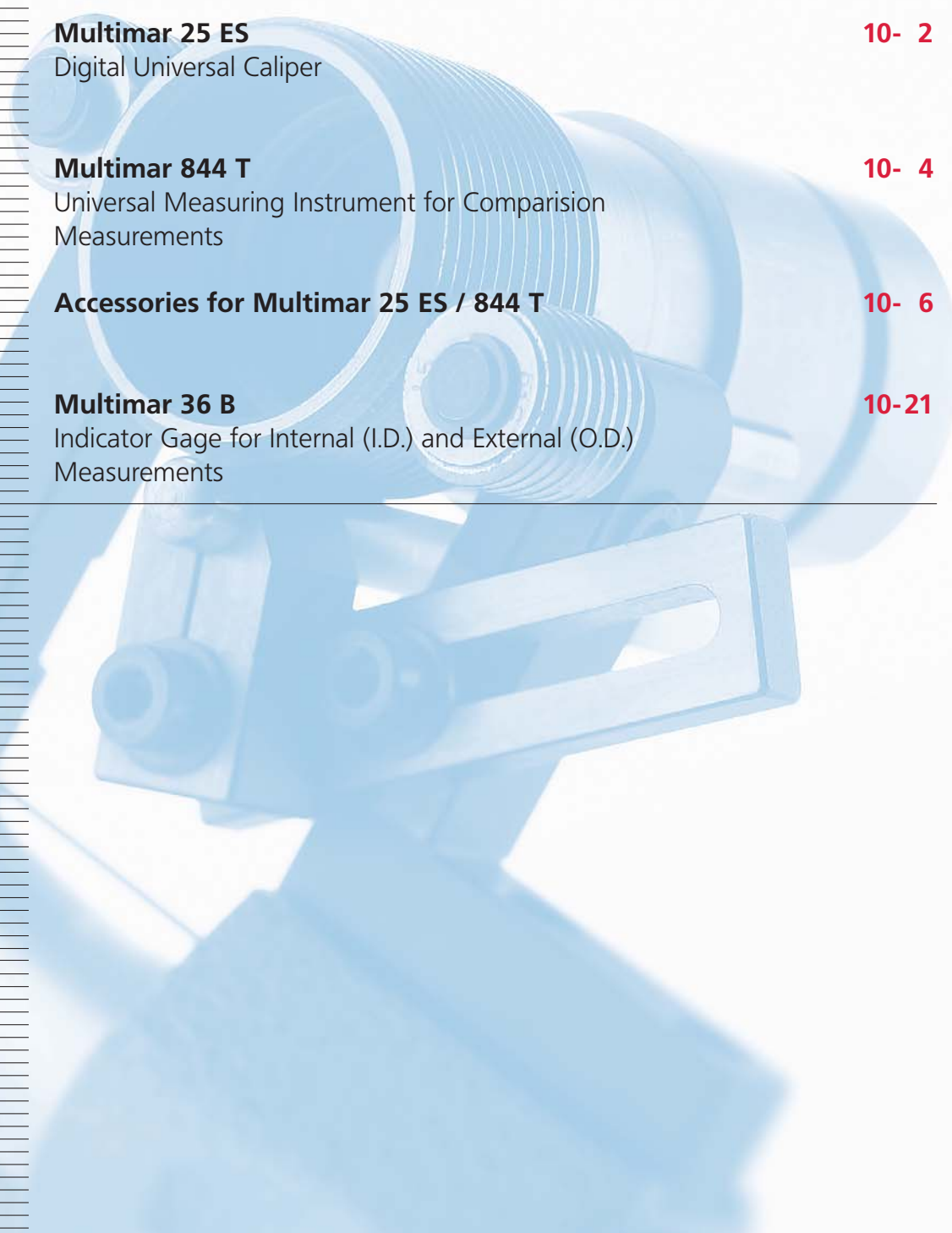

Digital Universal Caliper 25 ES Varimeter



Applications

- For measuring:
 - Outside and inside dimensions
 - Centering shoulders
 - Narrow collars
 - External and internal tapers
 - Dovetails
- Grooves
- Distances between hole centers
- For scribing of work pieces

Illustration is shown with accessories, these are sold separately

Features

Functions:

- ON/OFF
- RESET (zero setting) mm/inch
- HOLD (Storage of measuring values)
- DATA (Data transmission)
- PRESET (for entering a numerical value)
- TOL (Tolerance display)

- Capacitive measuring system, life of the battery ca. 2 years
- Max measuring speed: 1.5 m/s (60"/s)
- Data output: Opto RS232C via data connection cable
- High contrast 6 mm Liquid Crystal Display
- Interchangeable measuring arms

- Due to the patented mounting fixture of the measuring arms and or measuring attachments provided on both the upper and lower longitudinal face of the arm holders, the digital display is always in the operator's line of vision
- The application range can be easily extended by reversing the measuring arms

- Both measuring arms can be moved along the beam thus having a well balanced weight distribution even with small dimensions
- Slide and beam are made of hardened stainless steel
- Supplied with: Battery

Technical Data

Measuring range*		Resolution	Error limit (DIN 862)	Weight	Order no.	Order no. wooden case
outside mm	inside mm					
0 - 300 (0 - 12")	25 - 325 (1 - 13")	0.01/ .0005"	0.03/ .0015"	770/ 1.7	4118700	4118750
0 - 300 (0 - 12")	25 - 325 (1 - 13")	0.01/ .0005"	0.03/ .0015"	750/ 1.6	4118701**	4118750
0 - 600 (0 - 24")	25 - 625 (1 - 25")	0.01/ .0005"	0.03/ .0015"	1050/ 2.3	4118702	4118751
0 - 1000 (0 - 40")	25 - 1025 (1 - 41")	0.01/ .0005"	0.04/ .0020"	1470/ 3.2	4118703	4118752

* Dependent upon which accessories are being used the measuring range can be extended by a further 75 mm (2.95") by reversing the measuring arms 844 Te/Tx

** Without fine adjustment

Accessories

	Order no.
Setting Gage, hardened steel, screwed in to wooden case	25 Eel 4118520
Battery 3V, Type CR 2032	4102520
Data Connection Cable RS232C (2 m), SUB-D-jack 9-pin	16 ESv 4102510

Accessories for Data Processing see Chapter 11

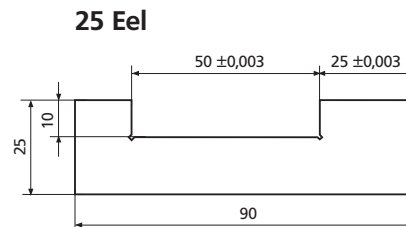

Multimar. Universal Gage 844 T for external and internal dimensions

OVERVIEW

► | The Universal Gage **Multimar** 844 T. Easy to use and versatile; ideal for all your measuring requirements in dimensional metrology. | ◀

Applications

- External and internal dimensions
- External and internal threads
- Centering shoulders
- Narrow collars, recesses and grooves
- External and internal tapers
- External and internal tooth profiles / gears
- and lots more

All indicating instruments with an 8 mm mounting shank can be used

Constant measuring force due to the built-in measuring force spring



The moveable measuring arm holder is mounted in a highly precision ball guide to eliminate both play and friction; it also has an extreme measuring sensitivity and accuracy due to the optimal stability and ease of movement

Technical Data

Application range*		Extended range of application mm/ <i>inch</i>	Distance of movable anvil mm/ <i>inch</i>	Weight g/lbs	Order no.**	Order no. Wooden case
mm	(<i>inch</i>)					
25 - 110	(1 - 4.33")	25 - 185 / 1 - 7.28"	10/ .4"	775 / 1.71	4500001	4500010
100 - 260	(4 - 10.24")	100 - 335 / 4 - 13.18"	10/ .4"	1010 / 2.23	4500002	4500011
250 - 610	(10 - 24.02")	250 - 685 / 10 - 26.96"	10/ .4"	1580 / 3.48	4500003	4500012
600 - 1010	(24 - 39.75")	600 - 1085 / 24 - 42.71"	10/ .4"	2225 / 4.91	4500004	4500013
1000 - 1500	(39.37 - 59.06")	1000 - 1575 / 39.37 - 62.01"	10/ .4"	2460 / 5.42	4500005***	-
1500 - 2000	(59.06 - 78.74")	1500 - 2075 / 59.06 - 81.69"	10/ .4"	2620 / 5.78	4500006***	-
2000 - 2500	(78.74 - 98.43")	2000 - 2575 / 78.74 - 101.38"	10/ .4"	2800 / 6.17	4500007***	-

* These application ranges only apply to internal measurements. For external measurements the range of application is reduced by 25 mm (1"). The extension of the application range takes place when the measuring elements are rotated through 180°.

All application ranges depend upon which anvil is being used.

From 1000 mm (range of application) a lightweight CRP tube is used.

** Excludes indicating instrument

*** Includes a transport and storage case

The basic Multimar 844 T gage is made from a rugged, ground and hard chrome plated column

The direction of the measuring force can be changed with an Allen key for either external or internal dimensions

The stationary measuring arm holder can be moved along the column for coarse adjustment

Adjustable stops for setting the measuring depth

The measuring arms for measurement of external and internal dimensions. By simply reversing the measuring arms the application range can be extended

Innovative lightweight construction of the basic body, made from carbon fiber reinforced plastic (CRP) tube, for measuring range 1000-1500 mm.



Indicating Instruments

All indicating instruments with a 8 mm mounting shank can be used. Recommended are:

Indicating Instrument	Readings mm/ <i>inch</i>	Order no. mm/ <i>inch</i>
MarCator 810 S	0.01 mm	4311000
Zentiness 1010 / 1010 Z	0.01 mm / .0005"	4332000/ 4332900
Compramess 1004 / 1004 Z	5 μm / .0001"	4333000/ 4333900
Digital Indicator MarCator 1087 B	0.001 mm* / .00005"	4337062
μMaxμm XL (XLI-30000)	1 μm / .00005^{μ*}	XLI-30000

* Resolution
For further digital indicators please refer to Chapter 5

Overview. Measuring Arms, Stops, Mounting Attachments and Anvils

Dimensions

Range of application		a
mm	(inch)	mm/inch
25 - 110	(1 - 4.33")	245 / 9.6"
100 - 260	(4 - 10.24")	395 / 15.5"
250 - 610	(10 - 24.02")	745 / 29.3"
600 - 1010	(24 - 39.75")	1145 / 45.0"
1000 - 1500	(39.37 - 59.06")	1675 / 65.9"
1500 - 2000	(59.06 - 78.74")	2175 / 85.6"
2000 - 2500	(78.74 - 98.43")	2675 / 105.3"

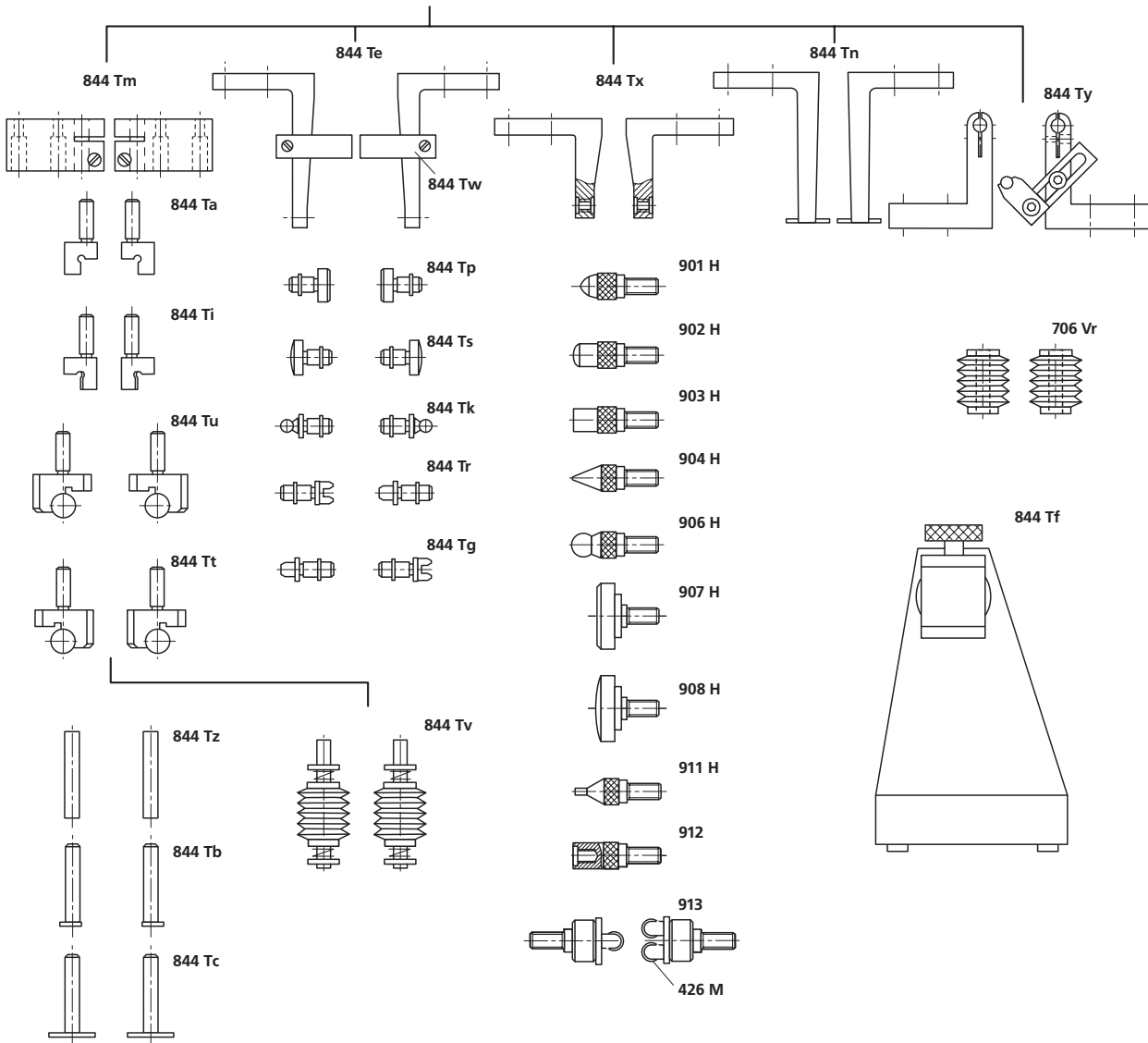
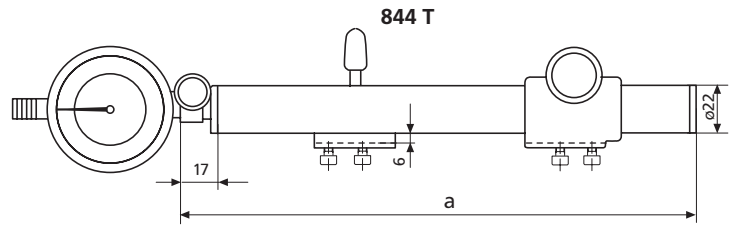

Overview. Measuring Arms, Stops and Mounting Attachments

Mounting Attachments 844 Tm

- Accommodates the following anvils 844 Ta, 844 Ti, 844 Tu, 844 Tt, 844 Tz, 844 Tb und 844 Tc
- Faces can also be used as stops
- Reversible arm holders for extending measuring range

Order no. **4500030**

Measuring Arms 844 Te

- For external and internal diameters
- With a 3.5 mm (0.138") diameter mount, accommodates the interchangeable anvils 844 Tp, 844 Ts, 844 Tk, 844 Tr and 844 Tg
- Reversible arm holders for extending measuring range

Throat depth a in mm	25	50	100*
Order no.	4500020	4500021	4500022

* Not suitable for Digital Caliper 25 ES

Stops 844 Tw

- To set the measuring depth limit. Can be attached and relocated on the following measuring arms 844 Te, 844 Tn, 844 Tx. Reversible for external and internal measurements

Order no. **4500109**

Measuring Arms 844 Tn

- Hardened steel
- To measure external and internal diameters on recesses and grooves at a greater measuring depth

Throat depth a in mm	100
Order no.	4500036*

* Not suitable for Digital Caliper 25 ES

Measuring Arms 844 Tx

- With an M 2.5 connection thread to screw in interchangeable anvils
- For internal and external dimensions on specially formed work pieces
- Measuring arms in conjunction with the measuring arms holder is reversible thus extending the range of measurement / application

Throat depth a in mm	25	50	100
Order no.	4500080	4500081	4500082*

* Not suitable for Digital Caliper 25 ES

Holder for Measuring Rollers 844 Ty

- With location bolts for the Measuring Rollers 706 Vr, plus a stop and stop pin

Order no. **4502463**

844 Tm

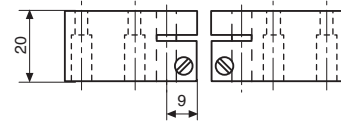

844 Te

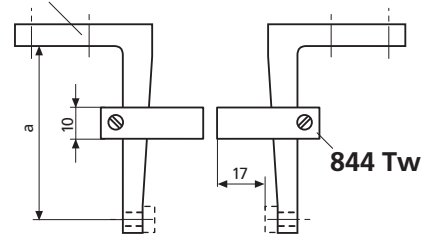

844 Tn

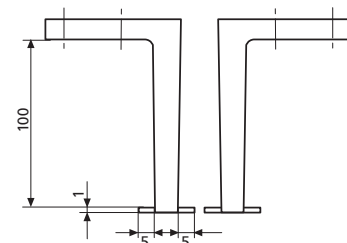

844 Tx

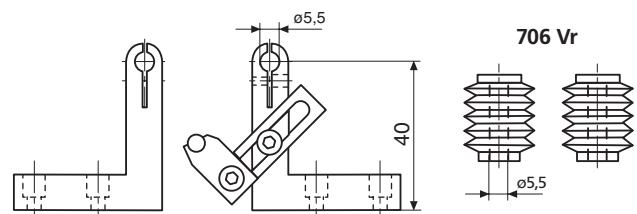
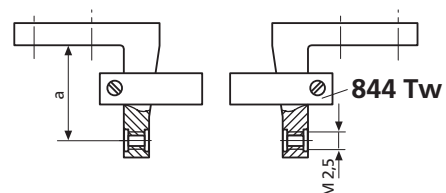

Measuring external and internal dimensions

Anvils for Measuring Arms 844 Te

- Hardened steel
- With a cylindrical mounting shank and retainer ring that allows free rotation in the bore of measuring arms 844 Te

Cat. no.

Order no.

844 Tp Flat; for external diameters, distance and widths

4500040*

844 Ts Spherical; for internal diameters

4500045*

* 2 pieces are required

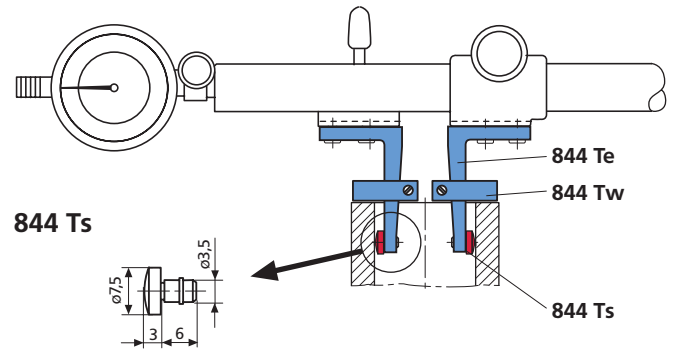
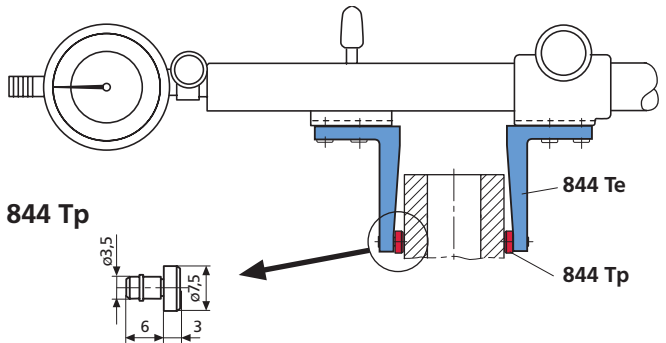

Shoulder anvils for mounting attachments 844 Tm

- Made from hardened steel
- For measuring narrow collars such as centering shoulders and other similar measuring tasks
- With cylindrical mounting shaft to attach into the mounting attachments 844 Tm

Cat. no.

Order no.

844 Ta Flat; for external diameters

4500050

844 Ti Semi-cylindrical, for internal diameters

4500055

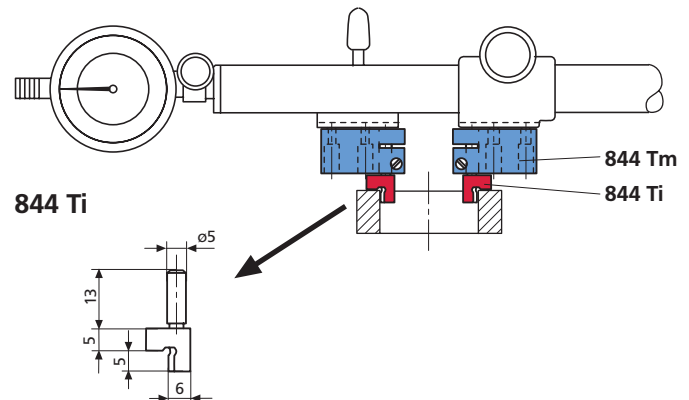
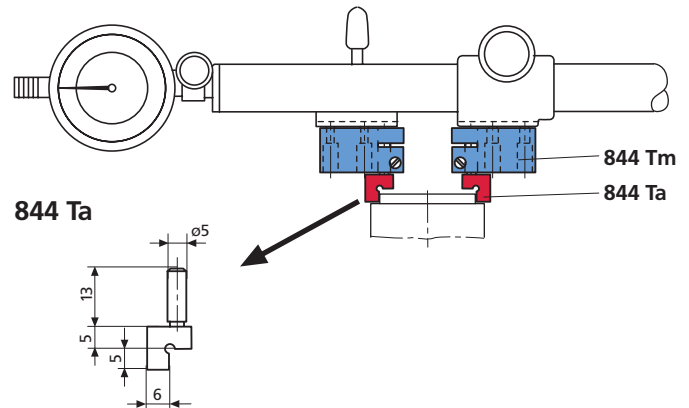

Measuring tapers and distances

Roller Anvils 844 Tu* for Mounting Attachments 844 Tm

- To measure the diameter of **outside tapers and dovetail guides**
- Roller is made of hardened steel

Cat. no.			Order no.
844 Tu*	Roller dia.	8 mm	4500047
	Roller length	14 mm	
	Distance of the roller to the stop face	5 mm ± 3 μm	

Ball Anvils 844 Tt* for Mounting Attachments 844 Tm

- To measure the diameter of **inside tapers** with a distance of 5 mm from the taper face
- Ball is made of hardened steel

Cat. no.			Order no.
844 Tt*	Ball dia.	8 mm	4500046
	Distance of the ball to the stop face	5 mm ± 3 μm	

* Outer and inner surfaces that are parallel to one another a combination sets (pair) consisting of a Roller Anvil 844 Tu and a Ball Anvil 844 Tt, are recommended.

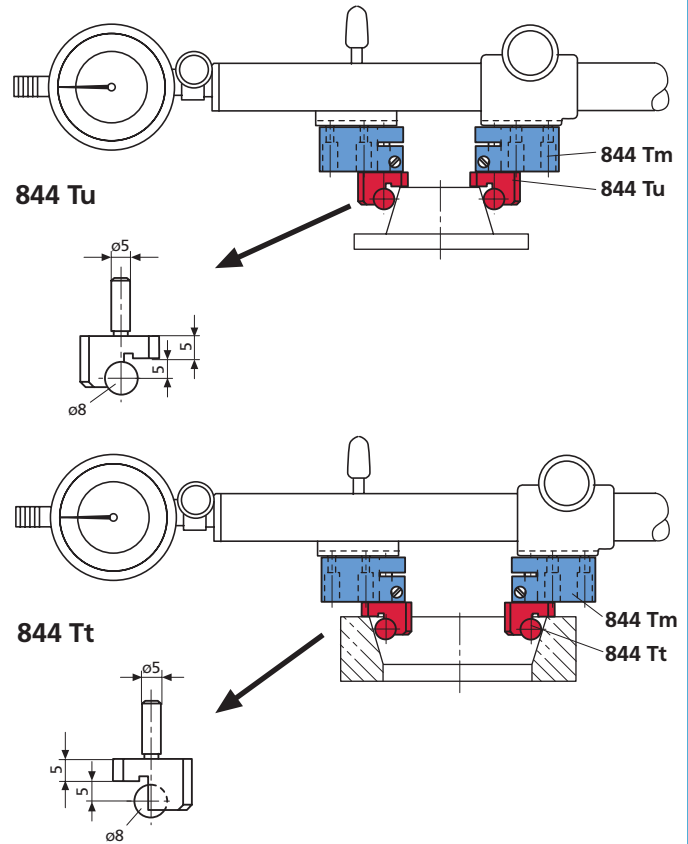

Measuring recesses

Anvils with Measuring Blades for Mounting Attachments 844 Tm

- For measuring centering shoulders and recesses on internal and external diameters; consists of a pin type holder, which is be moved to set the measuring depth in Mounting Attachment 844 Tm and a mounted measuring blade
- The face of the Mounting Attachment 844 Tm serves as stop

844 Tb

- With round measuring blades
- Ideal for workpieces that have a recess up to 2 mm in depth

844 Tc

- With long measuring blades
- Ideal for workpieces that have a recess up to 7.5 mm in depth

Cat. no.	Blade Length	Blade dia.	Range of adjustment	Order no.
mm	mm	mm		
844 Tb	–	9	0 – 10	4500015*
844 Tc	20	–	0 – 10	4500114*
	20	–	40 – 50	4500115*

* 2 pieces are required

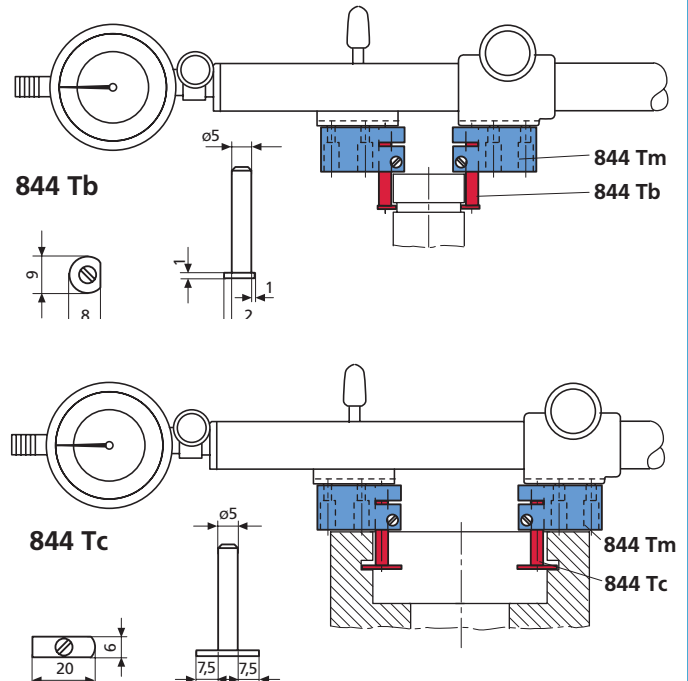

Measuring external and internal tooth profiles

Ball Anvils 844 Tk

Use in conjunction with Measuring Arms 844 Te

- Made of carbide. With cylindrical mounting shank and retainer ring which allows **free rotation inside the bore of Measuring Arms 844 Te.**

Especially suited for the measurement of internal or external helical gear wheels.

Shank dia. 3.5 mm
 Shank length 6 mm
 Manufacturing tol. ball dia. $\pm 2 \mu\text{m}$

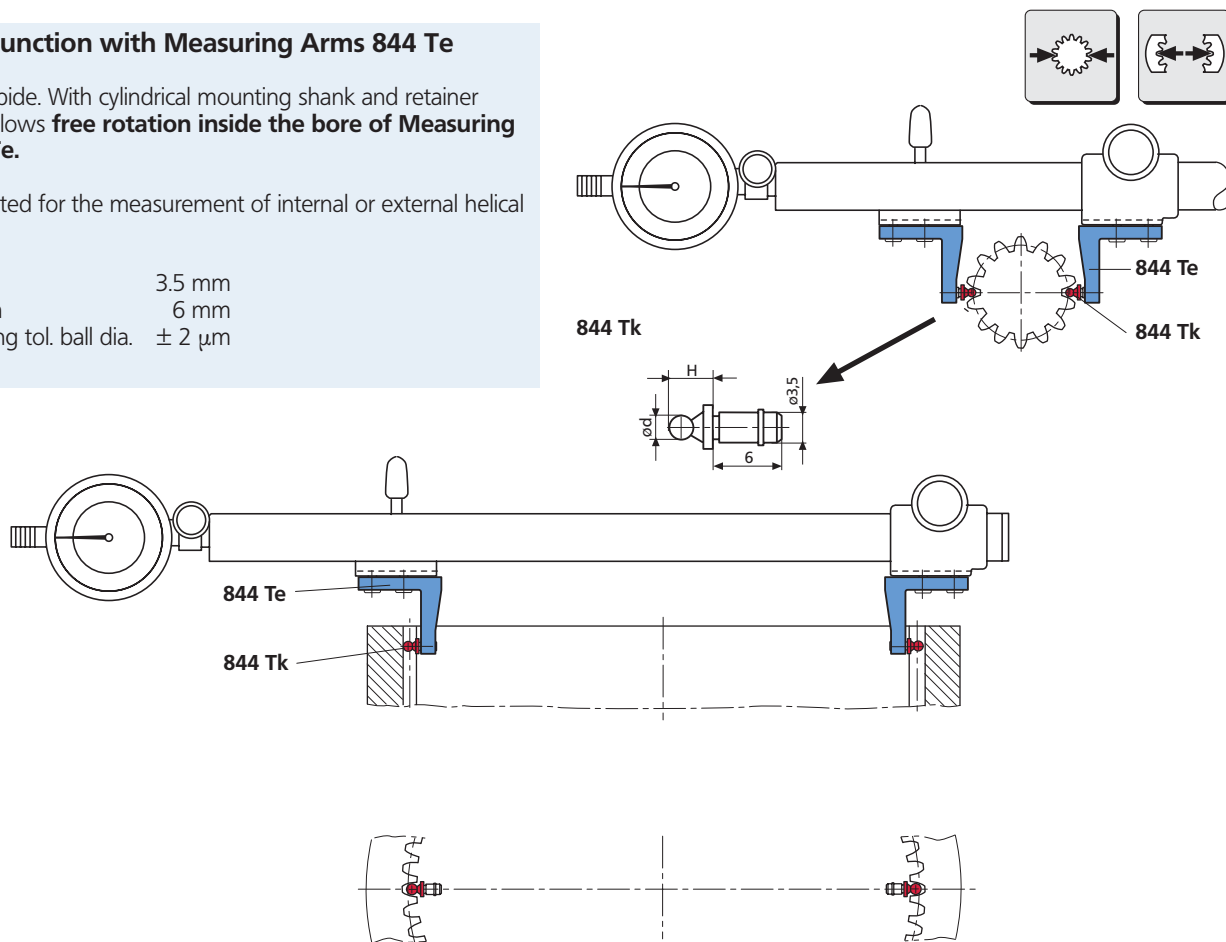

dia. d mm	H mm	Order no.*	dia. d mm	H mm	Order no.*	dia. d mm	H mm	Order no.*	dia. d mm	H mm	Order no.*
0.5	3.0	4502620	1.5	4.0	4500352	2.438	4.9	4502646	4.5	7.0	4500360
0.551	3.1	4502621	1.524	4.0	4502635	2.5	5.0	4500356	4.835	7.3	4502655
0.62	3.1	4502622	1.54	4.0	4502636	2.667	5.2	4502647	5	7.5	4500361
0.623	3.1	4502623	1.6	4.1	4502637	2.704	5.2	4502648	5.25	7.8	4502656
0.63	3.1	4502624	1.65	4.2	4502638	2.713	5.2	4502649	5.486	8.0	4502657
0.722	3.2	4502625	1.7	4.2	4502639	2.721	5.2	4502650	5.5	8.0	4500362
0.862	3.4	4502626	1.75	4.3	4500353	2.743	5.2	4502651	6	8.5	4500363
0.895	3.4	4502627	1.782	4.3	4502640	2.75	5.3	4500618	6.096	8.6	4502658
0.965	3.5	4502628	1.8	4.3	4502641	3	5.5	4500357	6.35	8.9	4502545
1	3.5	4500350	1.829	4.3	4502642	3.048	5.5	4502652	6.5	9.0	4502542
1.1	3.6	4502629	1.9	4.4	4502643	3.25	5.8	4502541	7	9.5	4502547
1.118	3.6	4502630	2	4.5	4500354	3.4	5.9	4502653	8	10.5	4502548
1.125	3.6	4502631	2.032	4.5	4502543	3.5	6.0	4500358	9	11.5	4502549
1.25	3.8	4500351	2.25	4.8	4502540	3.658	6.2	4502654	10	12.5	4502550
1.35	3.9	4502632	2.284	4.8	4502644	4	6.5	4500359			
1.372	3.9	4502633	2.3	4.8	4502544						
1.385	3.9	4502634	2.386	4.9	4502645						

* 2 pieces are required

Further sizes are available upon request (material: Steel)

Measuring external and internal tooth profiles

Cylindrical Measuring Pins 844 Tz

Use in conjunction with Mounting Attachments 844 Tm

- Made from steel, with shank for mounting into the Mounting Attachment 844 Tm.

Manufacturing tol. $\pm 2 \mu\text{m}$

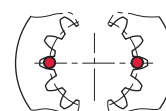
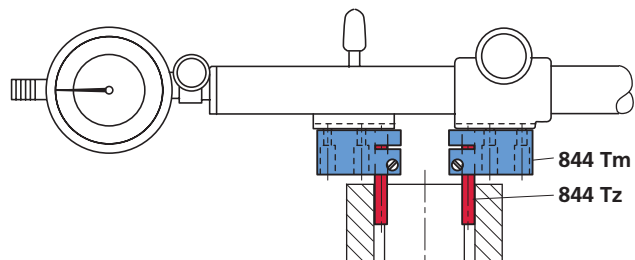
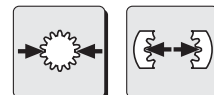

dia. D_M mm	Length l mm	Length L mm	Order no.
1	6	19.5	4500500
1.25	6	19.5	4500501
1.5	6	19.5	4500502
1.75	10	23.5	4500503
2	10	23.5	4500504
2.5	10	23.5	4500506
3	15	28.5	4500507
3.5	15	28.5	4500508
4	15	28.5	4500509
4.5	20	33.5	4500510
5	20	33.5	4500511
5.5	20	33.5	4500512
6	20	33.5	4500513

Further sizes are available upon request (material: Steel)

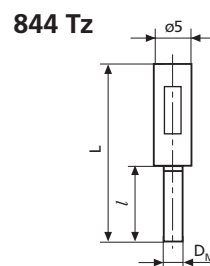

Measuring external threads

Interchangeable Anvils 844 Tr

Used in conjunction with Measuring Arms 844 Te

- Pair consists of V-anvil and blade

For pitch diameters

Shank dia. 3.5 mm
Shank length 6 mm

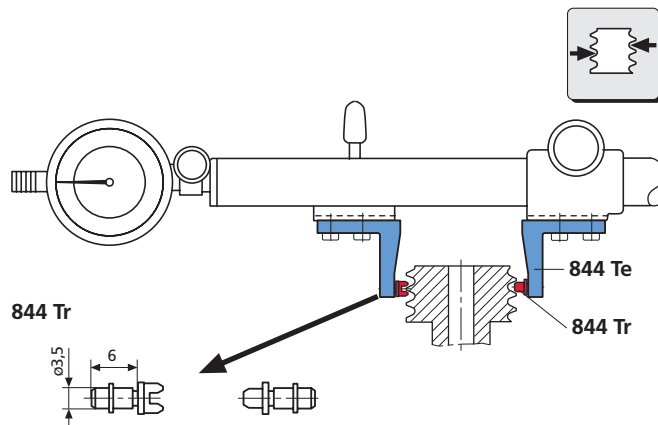

Metric external thread (60°)			Whitworth external thread (55°)			American UST external thread (60°)		
Pitch	V-anvil	Blade	Pitch range	V-anvil	Blade	Pitch range	V-anvil	Blade
mm	Order no.	Order no.	tpi	Order no.	Order no.	tpi	Order no.	Order no.
0.5 - 0.7	4501000	4501200	40 - 32	4501007	4501207	40 - 32	4501018	4501418
0.7 - 1	4501001	4501201	32 - 24	4501008	4501208	32 - 24	4501019	4501419
1.25 - 2	4501002	4501202	24 - 18	4501009	4501209	24 - 18	4501020	4501420
2 - 3.5	4501003	4501203	18 - 14	4501010	4501210	18 - 14	4501021	4501421
3.5 - 5	4501004	4501204	14 - 10	4501011	4501211	14 - 10	4501022	4501422
5 - 7	4501005	4501205	10 - 7	4501012	4501212	10 - 7	4501023	4501423
7 - 9	4501006	4501206	7 - 4.5	4501013	4501213	7 - 4.5	4501024	4501424
			4.5 - 3	4501014	4501214	4.5 - 3	4501025	4501425
			3 - 2.5	4501015	4501215			

For pitch diameters

Trapezoid external thread acc. to DIN 103

Pitch	V-anvil	Blade
mm	Order no.	Order no.
1	4501150	4501350
1.5	4501151	4501351
2	4501152	4501352
3	4501153	4501353
4	4501154	4501354
5	4501155	4501355
6	4501156	4501356
7	4501157	4501357
8	4501158	4501358
9	4501159	4501359
10	4501160	4501360

Measuring external threads

Interchangeable Anvils 844 Tr

Used in conjunction with Measuring Arms 844 Te

- Pair consists of V-anvil and blade
- Each pitch requires a separate V-anvil
- Blade can be used for several pitches

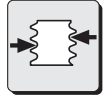

For root diameters

Shank dia. 3.5 mm
Shank length 6 mm

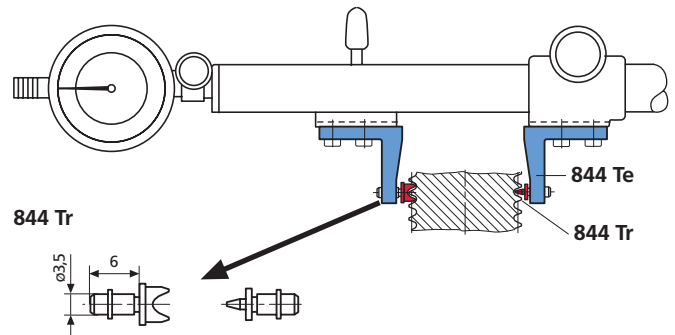

Metric external thread (60°)			Whitworth external thread (55°) American UST external thread (60°)		
Pitch	V-anvil	Blade	Pitch	V-anvil	Blade
mm	Order no.	Order no.	range tpi	Order no.	Order no.
0.5	4501026	4501232	40	4501083	4501284
0.6	4501027		36	4501108	
0.7	4501028		32	4501084	
0.75	4501029		28	4501085	
0.8	4501030	26	4501086		
0.9	4501031	24	4501087		
1	4501032	22	4501088	4501290	
1.25	4501033	20	4501089	4501293	
1.5	4501034	19	4501090		
1.75	4501035	18	4501091		
2	4501036	16	4501092	4501296	
2.5	4501037	14	4501093		
3	4501038	12	4501094	4501299	
3.5	4501039	11	4501095		
4	4501040	10	4501096	4501302	
4.5	4501041	9	4501097		
5	4501042	8	4501098		
5.5	4501043	7	4501099	4501306	
6	4501044	6	4501100		
7	4501045	5	4501101		
8	4501046	4.5	4501102		
9	4501047	4	4501103		
		3.5	4501104		
		3.25	4501105		
		3	4501106		

Measuring internal threads

Interchangeable Anvils 844 Tg

Used in conjunction with Measuring Arms 844 Te

- Pair consists of V-anvil and tapered anvil.

For pitch diameter

Shank dia. 3.5 mm
Shank length 6 mm

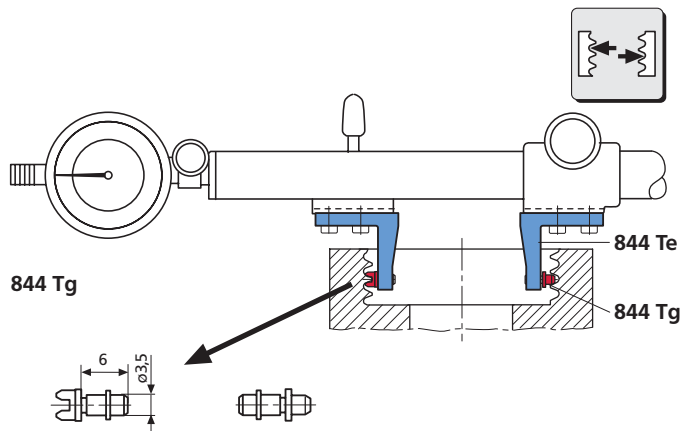

Metric internal thread (60°)			Whitworth internal thread (55°)			American UST internal thread (60°)		
Pitch	V-anvil	Tapered anvil	Pitch range	V-anvil	Tapered anvil	Pitch range	V-anvil	Tapered anvil
mm	Order no.	Order no.	tpi	Order no.	Order no.	tpi	Order no.	Order no.
0.5 - 0.7	4174300	4174600	40 - 32	4174343	4174643	40 - 32	4174415	4174615
0.7 - 1	4174301	4174601	32 - 24	4174344	4174644	32 - 24	4174416	4174616
1.25 - 2	4174302	4174602	24 - 18	4174345	4174645	24 - 18	4174417	4174617
2 - 3.5	4174303	4174603	18 - 14	4174346	4174646	18 - 14	4174418	4174618
3.5 - 5	4174304	4174604	14 - 10	4174347	4174647	14 - 10	4174419	4174919
5 - 7	4174305	4174605	10 - 7	4174348	4174648	10 - 7	4174420	4174620
7 - 9	4174306	4174606	7 - 4.5	4174349	4174649	7 - 4.5	4174421	4174621
			4.5 - 3	4174350	4174650	4.5 - 3	4174422	4174622
			3 - 2.5	4174351	4174651			

Trapezoid external thread acc. to DIN 103

Pitch	V-anvil	Tapered anvil
mm	Order no.	Order no.
1	4501830	4501831
1.5	4501832	4501833
2	4501834	4501835
3	4501836	4501837
4	4501838	4501839
5	4501840	4501841
6	4501842	4501843
7	4501844	4501845
8	4501846	4501847
9	4501848	4501849
10	4501850	4501851

Measuring internal threads

Interchangeable Anvils 844 Tg

Used in conjunction with Measuring Arms 844 Te

- Pair consists of V-anvil and pointed anvil
- Each pitch requires a separate V-anvil
- Pointed anvil can be used for several pitches.

For external diameters

Shank dia. 3.5 mm
Shank length 6 mm

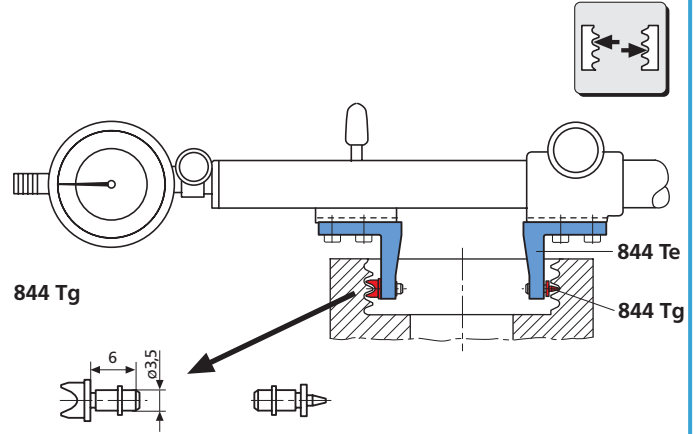

Metric internal thread (60°)			Whitworth internal thread (55°) American UST internal thread (60°)		
Pitch mm	V-anvil Order no.	Pointed anvil Order no.	Pitch range tpi	V-anvil Order no.	Pointed anvil Order no.
0.5	4174313	4174619	40	4174431	4174632
0.6	4174314		36	4174427	
0.7	4174315		32	4174432	
0.75	4174316		28	4174433	
0.8	4174317	26	4174435		
0.9	4174318	24	4174436		
1	4174319	22	4174437	4174939	
1.25	4174321	20	4174438		
1.5	4174322	19	4174439	4174943	
1.75	4174323	18	4174440		
2	4174325	16	4174442	4174947	
2.5	4174326	14	4174443		
3	4174327	12	4174445	4174949	
3.5	4174329	11	4174446		
4	4174330	10	4174447	4174949	
4.5	4174331	9	4174449		
5	4174333	8	4174450	4174655	
5.5	4174334	7	4174451		
6	4174335	6	4174453	4174660	
7	4174337	5	4174454		
8	4174338	4.5	4174455		
9	4174339	4	4174457		
		3.5	4174458		
		3.25	4174459		
		3	4174460		

Measuring external and internal threads

Interchangeable Measuring Rollers 844 Tv

Used in conjunction with Mounting Attachment 844 Tm

- Mounting shank fits into Mounting Attachment 844 Tm
- Each has two springs to alleviate the positioning on the correct pitch thread

Mounting Shank dia.: 5 mm

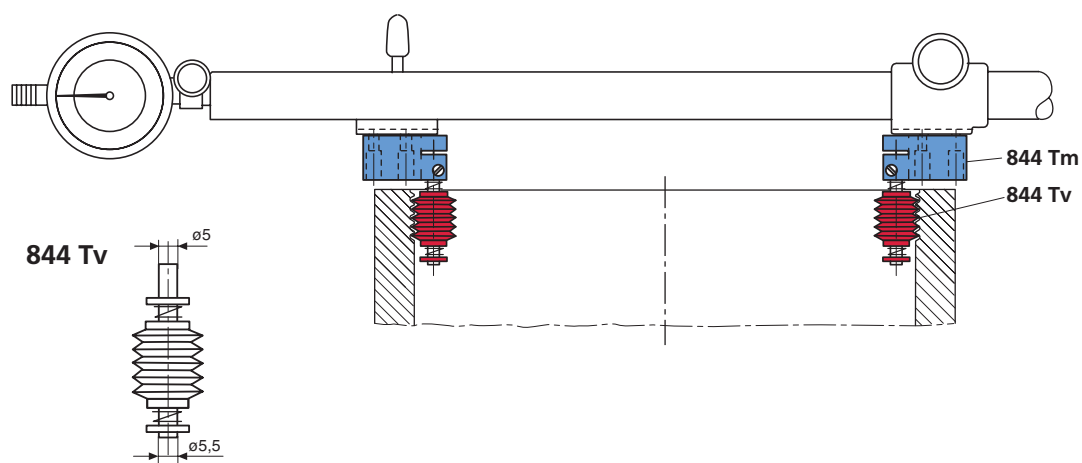

Metric Thread (60°)		Whitworth Thread (55°)		American UST Thread (60°)	
Pitch mm	Order no.	Range tpi	Order no.	Range tpi	Order no.
0.5	4501705	40	4501769	40	4501819
0.6	4501706	36	4501768	36	4501818
0.7	4501707	32	4501767	32	4501817
0.75	4501708	30	4501766	30	4501816
0.8	4501709	28	4501765	28	4501815
0.9	4501710	24	4501764	24	4501814
1	4501711	22	4501763	22	4501813
1.25	4501712	20	4501762	20	4501812
1.5	4501713	19	4501761	19	4501811
1.75	4501714	18	4501760	18	4501810
2	4501715	16	4501759	16	4501809
2.5	4501716	14	4501758	14	4501808
3	4501717	13	4501757	13	4501807
3.5	4501718	12	4501756	12	4501806
4	4501719	11	4501755	11	4501805
4.5	4501720	10	4501754	10	4501804
5	4501721	9	4501753	9	4501803
5.5	4501722	8	4501752	8	4501802
6	4501723	7	4501751	7	4501801
		6	4501750	6	4501800

Special Threads. Interchangeable Measuring Rollers for special threads are also available on request.

Measuring external threads

Measuring Roller Holder 844 Ty

- With location bolts for the Measuring Rollers 706 Vr
- With stop and stop pin

Order no. **4502463**

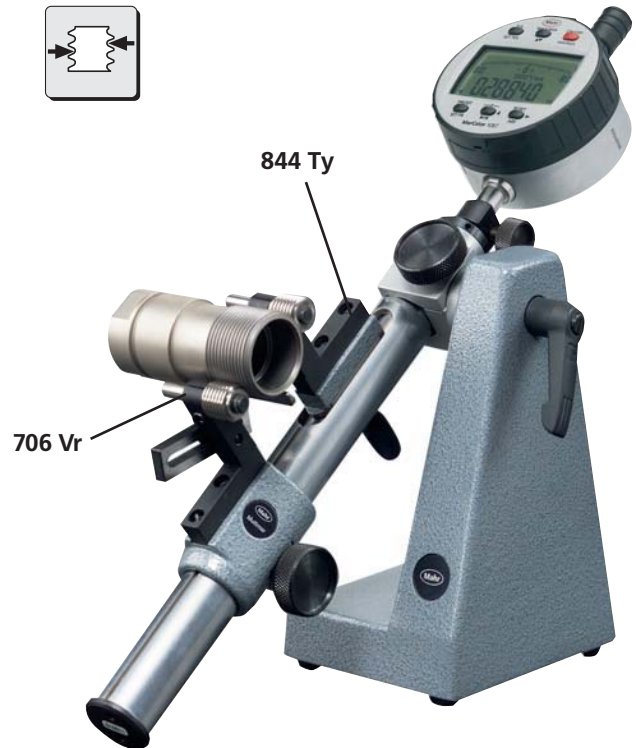
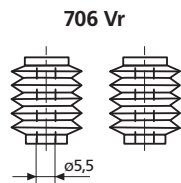
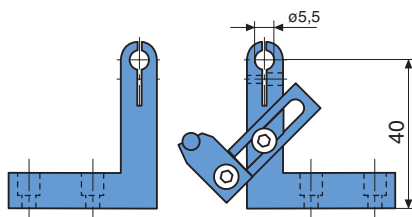
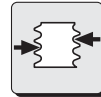

Thread Measuring Rollers 706 Vr

Used in conjunction with Measuring roller holder 844 Ty

Metric Thread (60°)		Whitworth Thread (55°)		American UST Thread (60°)	
Pitch mm	Order no.	Range tpi	Order no.	Range tpi	Order no.
0.5	4521105	40	4521219	40	4521319
0.6	4521106	36	4521218	36	4521318
0.7	4521107	32	4521217	32	4521317
0.75	4521108	30	4521216	30	4521316
0.8	4521109	28	4521215	28	4521315
0.9	4521110	24	4521214	24	4521314
1	4521111	22	4521213	22	4521313
1.25	4521112	20	4521212	20	4521312
1.5	4521113	19	4521211	19	4521311
1.75	4521114	18	4521210	18	4521310
2	4521115	16	4521209	16	4521309
2.5	4521116	14	4521208	14	4521308
3	4521117	13	4521207	13	4521307
3.5	4521118	12	4521206	12	4521306
4	4521119	11	4521205	11	4521305
4.5	4521120	10	4521204	10	4521304
5	4521121	9	4521203	9	4521303
5.5	4521122	8	4521202	8	4521302
6	4521123	7	4521201	7	4521301
		6	4521200	6	4521300

Special Threads. Interchangeable Measuring Rollers for special threads are also available on request.

Measuring external and internal dimensions

Measuring Arms 844 Tx and associated Anvils

- With an M 2.5 connection thread to screw in the interchangeable anvils
- For internal and external dimensions on specially formed work pieces
- Measuring arms on the measuring arm holder are reversible, therefore extending the range of measurement / application

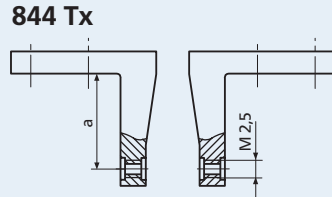

Throat depth a mm	25	50	100
Order no.	4500080	4500081	4500082*

* Not suitable for Digital Caliper 25 ES

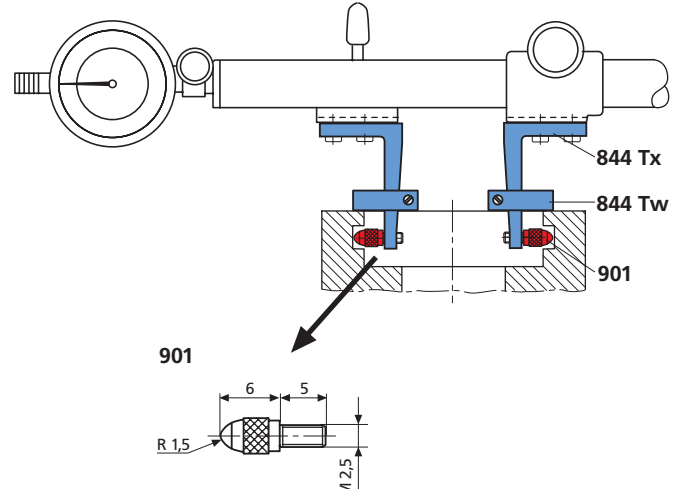

Standard Contact Points / Anvils 901, Ball dia. 3 mm

Cat. no.		Order no.
901	with Steel ball	4360001
901 H	with Carbide ball	4360002
901 R	with Ruby ball	4360003

Spherical Contact Points 902/Flat Contact Points 903

Length l mm	902	902 H	903	903 H
	Steel	Carbide meas. face	Steel	Carbide-tipped
	Order no.	Order no.	Order no.	Order no.
4	4360007	–	4360070	–
6	4360009	–	4360071	4360101
8	4360010	4360040	4360072	4360102
10	4360011	4360041	4360073	4360103
12	4360012	4360042	4360074	4360104
15	4360013	4360043	4360075	4360105
20	4360014	4360044	4360076	4360106
25	4360015	4360045	4360077	4360107
30	4360016	4360046	4360300	4360110
35	4360017	4360047	4360078	4360108
40	4360019	4360049	4360310	4360111
45	4360026	4360050	4360303	–
50	4360018	4360048	4360079	4360109
55	4360031			
65	4360035			
75	4360020			
85	4360036			
95	4360029			

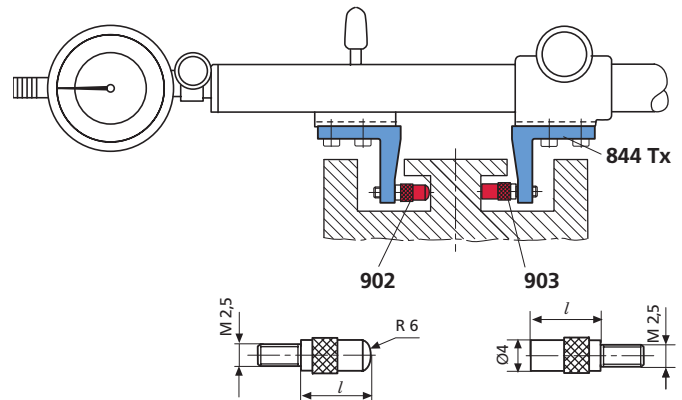

Measuring external and internal dimensions

Measuring Arms 844 Tx and associated Anvils

Ball Contact Points 906 H

With carbide ball. manufacturing tolerance ball dia. 0/-6 μm

Ball dia. d mm	l mm	Order no.	Ball dia. d mm	l mm	Order no.
1	8.5	4360150	5.5	9	4360161
1.25	8.5	4360151	6	9	4360162
1.5	8.5	4360152	6.35 (1/4")	9	4360163
1.75	8.5	4360153	6.5	10	4360164
2	8.5	4360154	7	10	4360165
2.5	8.5	4360155	7.5	11	4360166
3	8.5	4360156	8	11	4360167
3.5	8.5	4360157	8.5	12	4360168
4	8.5	4360158	9	12	4360169
4.5	8.5	4360159	10	13	4360170
5	9	4360160			

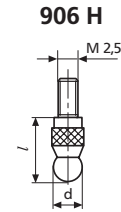

Measuring Spindle Extensions 912

Length l mm	Order no.	Length l mm	Order no.
10	4360250	35	4360254
15	4360251	50	4360255
20	4360252	75	4360256
25	4360253	100	4360257

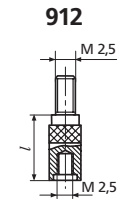

Special Contact Points / Anvils

	Order no.
Conical Contact Points , carbide tipped	904 H 4360131
Flat Contact Points* , steel, A = 1 cm ²	907 4360200
carbide tipped, dia. 7 mm	907 H 4360201
Spherical Contact Points , steel	908 4360210
carbide tipped	908 H 4360211
Pin Contact Point , carbide tipped, dia. 1 mm, flat	911 H 4360240
Flat Contact Point , for mounting a pin gage holder 426 M for measuring threads using the 3 wire method	913 4360400

* When using an anvil with a flat contact face the opposite anvil must have an spherical contact face.

Note:

The Order no's on pages 10-18 and 10-19 only related to one piece.

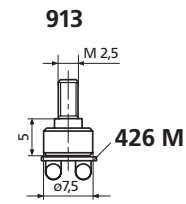
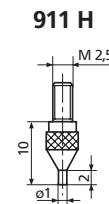
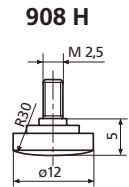
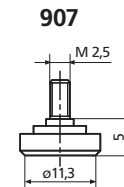
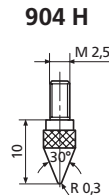

Scribing with Digital Universal Caliper 25 ES

Scriber Point 25 Es

- For straight lines and circles
- Made of hardened steel

Order no. 4118530

Counter Holder 25 Eh

- In conjunction with 25 Es to scribe straight lines, for example; along an edge
- Made of hardened steel

Order no. 4118535

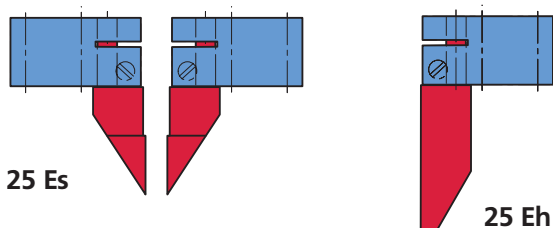

Anvils for Distances for Digital Universal Caliper 25 ES

Mounting Inserts 25 Eb

- For distances between the center of bores and between the center of a bore and an edge
- Carbide tipped
- Longest distance between hole centers corresponds with half the measuring range

Order no. 4118525

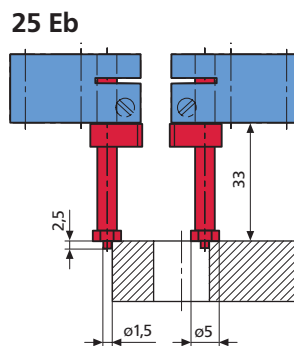

Stand 844 Tf for Universal Measuring Instrument 844 T

- For stationary use of the Universal Measuring Instrument 844 T
- Measuring range 25 - 110 mm
- User has both hands free for insertion of work piece
- The indicating instrument is always in the operator's line of vision
- Strong, stable cast base with clamping device for Universal Measuring Instrument

Order no. 4450512



I.D./O.D. Indicator Gage 36 B for Internal and External Dimensions

The economical way to check outside diameters on the shop floor.



EMD-36B-10

Features

- Adjustable retraction of sensitive contact allows measurement of grooves and races. Retraction, normally set at 6 mm / 0.25", is adjustable to 10 mm / 0.40".
- Frictionless reed-spring (pantograph) motion transfer for repeatability.
- Gaging pressure is adjustable from 0 - 35 N / 0 - 8 lb.
- Two styles available. 2-point "T"-Plate or 3-point "V"-Plate.
- Two sizes available.
- Adjustable base: Gage can be positioned on any angle from horizontal to vertical.
- Variety of readout devices available.
- Reverse the top-plate to change from I.D. to O.D. measurement.
- Supplied with JW-9 Jaws.

Indicating Instruments

All indicating instruments that has a 8 mm mounting shank may be used. Recommended are:

Catalog no.	Resolution	Order no.
MarCator 1087 μMaxμm	1 μm .5 μm	4337060 EDI-20302

Technical Data

Style	Capacity		Order no. With 0.0001" Dial Indicator	Order no. With 0.002 mm Dial Indicator	Order no.* With Maxμm®/III	Order no.* With Maxμm®/III & Output	Order no.* With μMaxμm & Output	Order no. w/o Indicator, metric 8 mm mount shank
	I.D.	O.D.						
"T" Plate	.75 - 5.5" 19 - 139 mm	.25 - 5" 6 - 127 mm	36B-10	36B-10M	EMD-36B-10	EMD-36B-10D	EDI-36B-10	2003200
"T" Plate	.75 - 7.75" 19 - 197 mm	.25 - 8.75" 6 - 222 mm	36B-20	36B-20M	EMD-36B-20	EMD-36B-20D	EDI-36B-20	2003201
"V" Plate	.812 - 4.625" 21 - 117 mm	.312 - 5" 8 - 127 mm	36B-9	36B-9M		EMD-36B-9D	EDI-36B-9	
"V" Plate	.812 - 9" 21 - 229 mm	.312 - 9.5" 8 - 241mm	36B-19	36B-19M		EMD-36B-19D	EDI-36B-19	

* Selectable Resolution

	Order no.
36B-10 with 1087B and Y & T Plate Sets	2061657
36B-20 with 1087B and Y & T Plate Sets	2061658

I.D./O.D. Indicator Gage 36 B for Internal and External Dimensions

"T" Plates

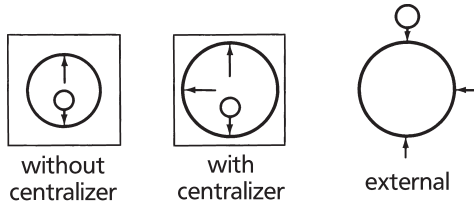

"T"-plates give a diameter reading directly across the diameter. A third contact may be used as a side-stop or centralizer.

"V" Plates

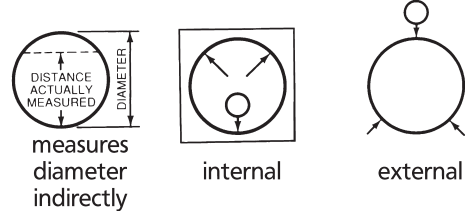

"V"-plates are self-centralizing. Three jaws are used and the measurement is of the distance between the sensitive contact and the chord formed by the two reference contacts. This measurement bears a direct relationship to the diameter and compensation is made by a special ratio indicator so diameter is read directly.

Used to inspect parts with odd number lobing conditions.

Jaw Sets

Model numbers on the preceding page include a set of **Model JW-9 Jaws**. **Model JW-58 Jaws** (tungsten carbide)



JW-9 Jaws (normally furnished)

Order no. (3 jaw set)	Adjustment Height	Material: Contact and Rest Surface	Replacement Contact Pins (3 required)
JW-9	0.79-19 mm / .031-.75"	Steel	PS-55
JW-58	0.79-18 mm / .031-.72"	Carbide	PS-226
2220461*	0.79-18 mm	Carbide	2225694

* Normally furnished with Metric Version.

For special jaw configurations or for other indicators contact Mahr Federal Customer Resources Center.

Max μ m[®] III Indicator for "V"-Plate Models

Digital Range	Stem Length	Order no.
± 1 mm / $\pm .040$ " or $\pm .199$ mm / $\pm .020$ "	17 mm / .670"	2033145*

* Max μ m[®] III 4:5 ratio model includes Data Output (6 pin) and user selectable setup for range, resolution, units and measuring direction.

EMD-36B-19D I.D./O.D. Gage

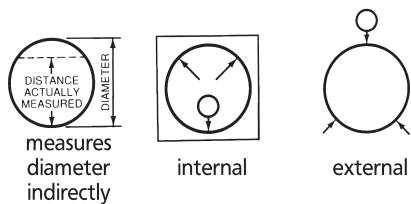

I.D./O.D. Indicator Gage 36 B for Internal and External Dimensions

Special Contacts: Steel

Special steel ball contacts can be made in a variety of different diameters for your measurement applications.



Special Contacts: Tungsten Carbide

Side mounted Tungsten Carbide spherical contacts can be made for measuring internal and external gears and splines.



Special Contacts: Doughnut

Specially designed Doughnut shaped contacts are used, as an example, in the bearing industry calling out for wider than normal contacts to reach into bearing raceways.



Special Contacts: TC Ball

Spherical diameter tips are ideal for measuring inside or outside radial formed recesses of precision parts.



Special Contacts: Pie Plate

Special jaws shaped like large half-discs, are used by the plastic industry to accurately measure semi-flexible round cups where reduced deflection is important.

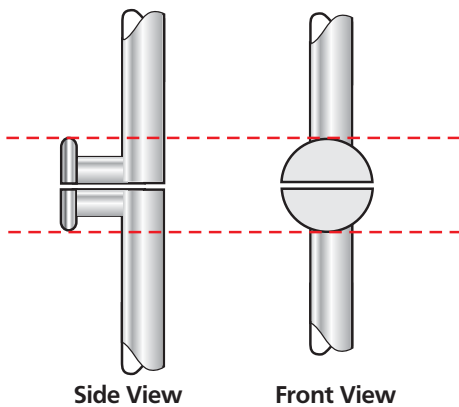

Side View

Front View

JW-58 w/TC Wear Pads

Specially designed jaws supplied with Tungsten Carbide wear surfaces provide extra long jaw life.



Additional Contacts

844T Contact Points for use with 36B Gage

We have added to the list of standard contacts by modifying the JW-9 jaws to accept some of the Universal Gage 844T contacts. This modification was done by reaming out the jaws from .186" to .196" diameters so that they will accept the contacts that are used with the 844TM holders.

With the added addition of the anvils below we have more measurement possibilities with the 36B gage such as Pitch Diameters of gears, Threads (Metric, Whitworth and American UST), Taper diameters and recesses.

For Threads and Cylindrical pins please see catalog pages 10-11 Cylindrical pins and 10-16 for threads.

Order no.

Flat shoulder anvils	Sold as a pair	4500050
Inside taper anvils	Sold as a pair	4500046
Measuring blades	Sold as a pair	4500114
Cylindrical Pins	Sold as a pair	See catalog page 10-11
Semi-cylindrical anvils	Sold as a pair	4500055
Outside taper anvils	Sold as a pair	4500047
Measuring blades	Sold as each	4500015
External/ internal threads	Sold as a pair	See catalog page 10-16

ARE YOU SEARCHING FOR THE RIGHT CONNECTIONS?
THEY'RE RIGHT HERE AT MARCONNECT.



The latest information on MARCONNECT products can be found on our website:
www.mahr.com, WebCode 213

4 USB-Geräte	Beschreibung Geraät, Anschlusskabel	Messwert Status	Anforderung Ziel
USB1	Fußschalter Schalter MCI	--.--	Messung Nr.: 0/1
USB2	Durchmesser 1 1087 16D <u>u</u>	+015.17	Schalter: Fußschalter Excel: Default.xlt/Tabelle1/1
USB3	Durchmesser 2 1087 16D <u>u</u>	+025.35	Schalter: Fußschalter Excel: Default.xlt/Tabelle1/2
USB4	Durchmesser 3 1087 16D <u>u</u>	+014.99	Schalter: Fußschalter Excel: Default.xlt/Tabelle1/3

► | Our new digital hand held measuring instruments are equipped with MarConnect interface capability. Regardless of which interface standard you use, whether USB, Opto RS232 or Digimatic; MarConnect will always provide you with the optimal connection.

▶ | MarConnect. Data Processing

USB Ready / MarCom Software

Overview

MarConnect USB Ready

11- 2

Simple data transmission to a PC as well as enables quick and universal assembly of a multiple measuring station.

MarCom Software

11- 2

Clear and flexible data acquisition

Statistics Printer

MarConnect MSP2

11- 4

Statistics printer with integrated Data Logger

Interfaces

MarConnect T-Box

11- 5

Interface to connect to a PC keyboard input

Radio Transmission

MarConnect Radio System FM 1

11- 6

Secure and wireless data transmission

MarConnect Radio System FM 2

11- 7

Secure and wireless data transmission

Overview

MarConnect Data Connection Cables

11- 8

To connect Measuring Instruments to Data Printers & External Devices

MarConnect. USB ready

► | The new flexible **MarConnect** interface from Mahr. Simplifies both data transmission to a PC and enables quick and universal assembly of a multiple measuring station. ◀ |



- **Choose alternative methods of data transmission** either with a foot switch or a PC keyboard, direct on the measuring instrument or with the Timer function

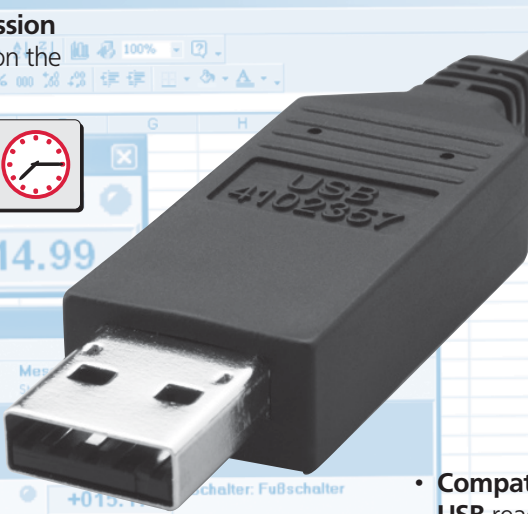

- **Compatible with all MarConnect USB ready measuring instruments**

- **Clear and flexible data acquisition** with the easy to use **MarCom Professional Software**

4 USB-Geräte	Beschreibung	Messwert	Anforderung
USB1	Schalter Messtation Schalter MC1	OK	Messung Nr.: 0/1
USB2	Werte 1 48x 180µ	+015.17	Excel: Default.xls/Tabelle1/1
USB3	Breite 180x 180µ	+025.35	Excel: Default.xls/Tabelle1/2
USB4	Messtation 3 180 180µ	+014.99	Timer 00:00:10 Excel: Default.xls/Tabelle1/1



- **Multiple measuring station** is easily set up with a USB hub, up to 100 measuring devices can be simultaneously connected

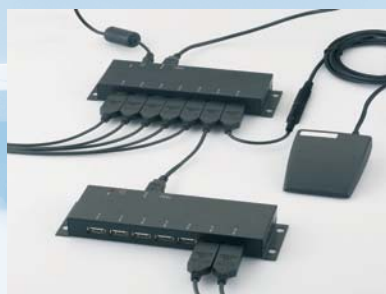

- **Easily extendable** with additional USB hubs

MarCom Software

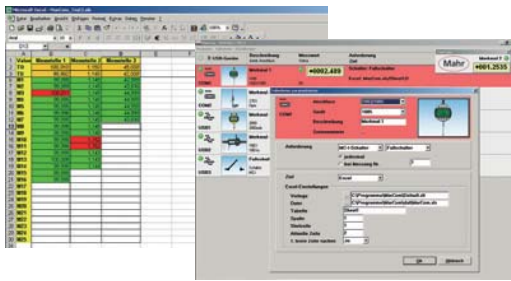

Features

Software MarCom Professional

- Directly transfer meas. values into MS Excel*, a text file or key code
- Measured values from each device can be sent to a different column, table or folder in Excel
- Data transmission is possible via USB and 2 serial COM interfaces
- USB hub is also suitable as a measuring instrument interface
- Up to 100 meas. devices can be connected with USB data cable
- Clear portrayal of selected meas. devices with the aid of icons
- Several foot switches can be connected via USB. meas. devices and be freely assigned

- Freely definable / configurable measurement cycles
- Data transmission via "Data" button on meas. devices or on the data cable; via a PC, timer, keyboard; or a foot switch connected to a USB interface

Software MarCom Standard

(USB cable is not included in the scope of supply)

Features and system requirements are identical to MarCom Professional, except that it only has one USB and one serial COM interface

System Requirements

IBM AT compatible PC
 USB interface, higher than 1.1
 Recommended: MS Excel from Version 97 onwards

MS Windows® 2000, XP, Vista
 CD / DVD drive

Order no.

Software MarCom Professional
 Software MarCom Standard

4102552
 4102551

USB ready measuring instruments

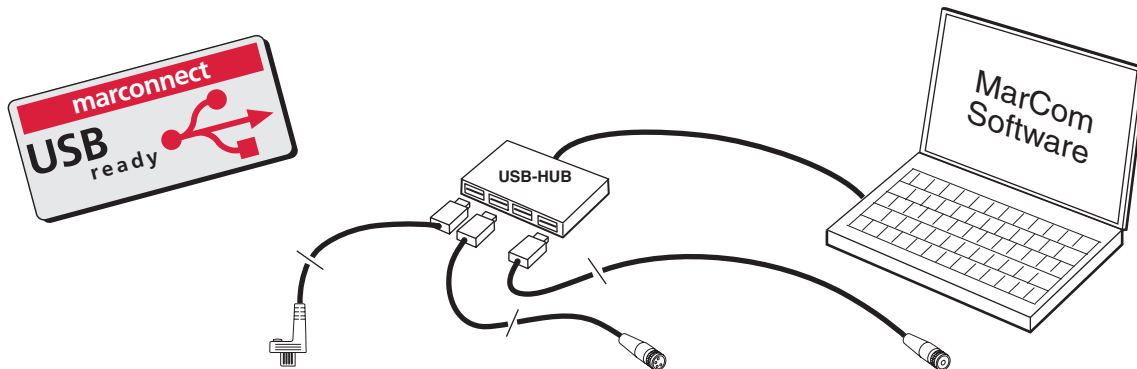

Data Connection Cable **16 EXu**
Order no. 4102357
 incl. MarCom Standard

Data Connection Cable **2000 usb**
Order no. 4346023
 incl. MarCom Standard

Data Connection Cable **MC-I**
Order no. 4102782
 incl. MarCom Standard

for **MarCal.** Calipers
 16 ER / EWR
 16 EWW
 18 EWR
 30 ER / EWN



for **Digimar.** Height Gages
 814 SR

for **Micromar.** Micrometers
 40 EW, 40 EWS, 40 EWW
 44 EX, 46 EX



for **MarCator.** Digital Indicators
 1075, 1080, 1081,
 1086, 1087



for **MarSurf.** PS1



for **MarCator.** Digital Indicators
 1088



for **Millimes.** Digital Comparators
 2000
 2001
 2100



for **Digimar.** 816 CL



for **Foot switch**
Order no. 4102058



USB-HUB 7-fold industrial model
220 V Order no. 4102553
110 V (US type) Order no. 2245786



Statistics Printer MSP 2 with integrated Data Logger

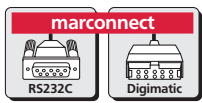

Above shows the Statistics Printer MSP2 being used in conjunction with the Transport Bag MSP 2t

Features

- Areas of application include; incoming goods department, on the production floor, in quality assurance department and in dispatch
- Can be connected to any of the following: Mahr Hand Measuring Instruments, Mahr Millimar Instruments, Digimatic compatible instruments and measuring instruments with a RS232C interface
- Two-line display for a simple dialog mode
- Real-time clock with date
- Measured values can easily be stored and transferred to a PC
- The following statistical parameters can be determined: process mean \bar{x} , range R , standard deviation σ and σ_n-1 , Min and Max of the measured values, $> UTol$, $< LTol$, machine capability C_m and C_{mk} , process capability C_p and C_{pk} for sampling sizes 2-25
- 3 types of print protocols: statistics, statistics with a histogram, sample charts
- List of measured values can be printed from the memory at any time
- Individual values can be chosen and deleted as desired
- Quiet and fast Thermo-printer (5 lines/sec.)
- Automatic data transfer with adjustable time interval parameter from between 1 sec. to 99 hrs.
- Alternative power sources include: mains adapter (100 - 240 V, batteries or NIMH-accumulator, type AA)
- Can be deployed as an interface to the PC
- Languages can be selected, German, English and French
- Supplied with: Mains adapter, paper roll

Technical Data

Max. measured values	999
Characters per line	24
Paper width	58 mm
Paper length	25 m
LxWxH	215 x 116 x 85 mm
Battery operation at 1100 mAh	> 7000 printed lines
Data logger powered by accu.	ca. 24 Hrs.
Protection class	IP40
Total weight incl. accu.	600 g

Order no. 4102040

Accessories

	Order no.
Foot Switch to trigger data transmission	4102058
Paper Rolls 1 Pack = 5 rolls	4102041
Transport Bag MSP 2t	4102042
Data Cable to connect MSP 2 to a PC (Data transfer / Interface mode)	4102711
Data Cable for connecting measuring instruments See cable overview on Page 11-10	
MarCom Software see Page 11-3	

T-Box interface to connect to measuring instruments to the keyboard input jack of a IBM compatible PC



T-Box 204 USB

Features

- Measuring data is converted into **keyboard codes**, therefore suitable for any software with a manual input (e.g. MS-Excel®)
 - No special driver software required
 - Independent of operating system (DOS, Windows, OS/2, Unix, Linux)
 - Measuring values can be processed individually or as a group
 - The measured values can be directly triggered on the measuring instrument or with the optional foot switch
 - Every Multi-RS232C interface is individually adjustable via the setup switch
 - Termination character (e.g. Enter) can be selected via switch
 - The power is supplied by the USB interface
 - Supplied with: USB cable
PS/2 cable
- Note:**
Only suitable for German, French, US keyboards or compatible!

Technical Data

	Inputs	Dimensions mm (L x W x H)	Order no.	Remarks
T-Box 204 USB	3 x Multi-RS232C Input 1 x Digimatic Input	130 x 180 x 40	9102519	When connecting Digimatic-measuring instruments the standard cable of the manufacturer can be used
T-Box 205 USB	2 x Multi-RS232C Input 3 x Digimatic Input	130 x 180 x 40	4102579	

Accessories

	Order no.
Foot Switch for connection to T-Box	4102556
Data Cable for connecting measuring instruments See cable overview on Page 11-8	

Digi-USB-1 Interface USB Interface with one Digimatic input port



Technical Data

1 x Digimatic - measuring instrument - input
Dimensions 20 x 57 x 33 mm

Order no. **4102523**

Features

- Power supplied by the USB interface
- No driver required for the USB interface
- The USB interface is recognized as a keyboard
- Termination character such as Enter or TAB can be set up on the USB interface
- Data- key for data transmission
- Supplied with: USB-Interface

Radio Transmission radio system FM 1*

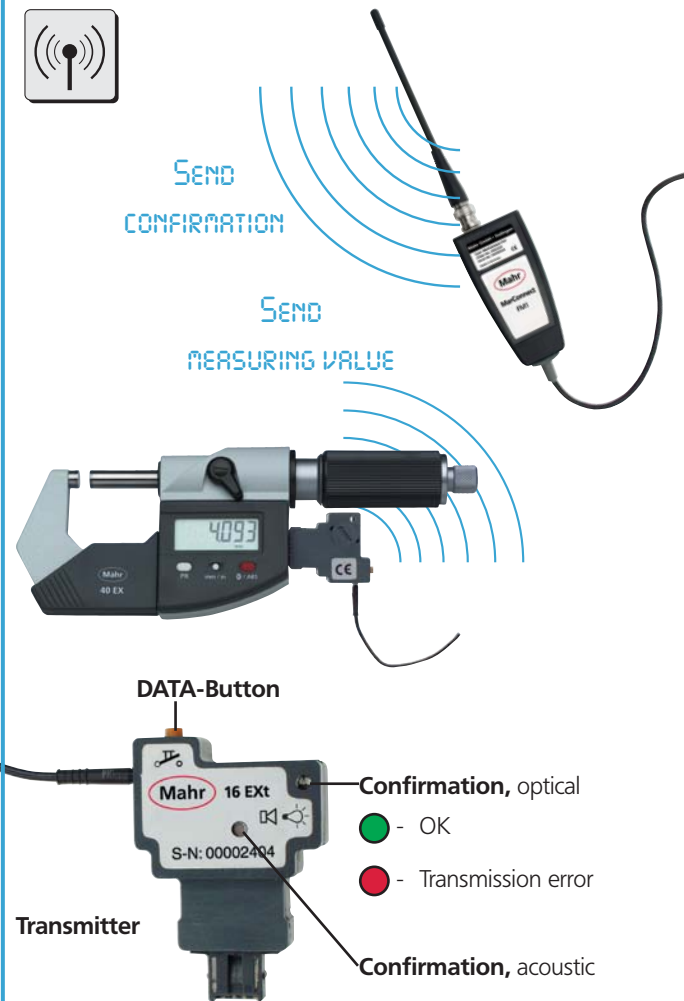

* Only available in North America, Canada and Mexico

Note:
FM 1 and FM 2 are not compatible with one another.

Transmitter

For Measuring Instruments			Order no.
MarCal	16 ER, 16 EWR, 16 EWV, 18 ER, 30 ER, 30 EWN	16 EXt	4102321
Digimar	814 SR		
Micromar	40 EW, 44 EX, 46 EX, 40 EWS, 40 EWV		
MarCator	1075, 1080, 1081, 1086, 1087		
MarCal	25 ES, 30 EWD, 31 ES, 32 ES	16 ESt	4102322
Digimar	27 ES, M 814		
MarTool	106 ES		
Millimar	C1208, C1216, C1245, S1840	RS232 t	2121317
Digimar	CX2, 817 CLM		

Contact Mahr Federal for transmitters to be used with:
 μMaxμm
 Digimatic devices
 Digimatic data cables

Features

- Secure data transmission with dialogue between receiver and transmitter
- Acoustic and optical confirmation of receipt by the transmitter
- Compact transmitter is connected directly on the interface of the measuring instrument
- Power is supplied for the receiver via a USB-Interface on the PC
- Up to 120 measuring instruments can be connected to the receiver
- Radio transmission distance is from 10 m up to 200 m (depending on the environment)
- Radio frequency is 433.926 MHz

The transmission of the measured value takes place via actuation of the DATA button on the transmitter. The transmitter supplements the measured value with an address number, a communication control word and a double check sum. The special data coding and the feedback from the PC to the transmitter ensures absolute data security.

A transmission error is recognized by the dialogue between PC and transmitter.

The data transmission is then repeated up to three times automatically within a few milliseconds

When the data is successfully transmitted the green light on the transmitter flashes and a short beep is heard confirming transmission.

Receiver

Receiver	Order no.
FM 1	4102320

For USB interface includes, driver and basic Sim Key software to store measured values in an MS-Excel file.

Sim Key software keeps track of every transmitters specific RF signature and assigns a frequency so incoming data transmissions are not lost.

Also supplied with MAHR_EXDLL Software (REQUIRES DONGLE ACCESS KEY) sold separately*

MAHR_EXDLL software offers more sorting options for incoming data transmissions.

*Dongle access key **2121335**

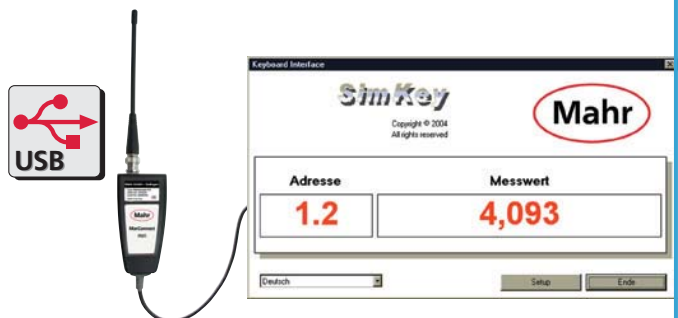

Radio transmission radio system FM 2

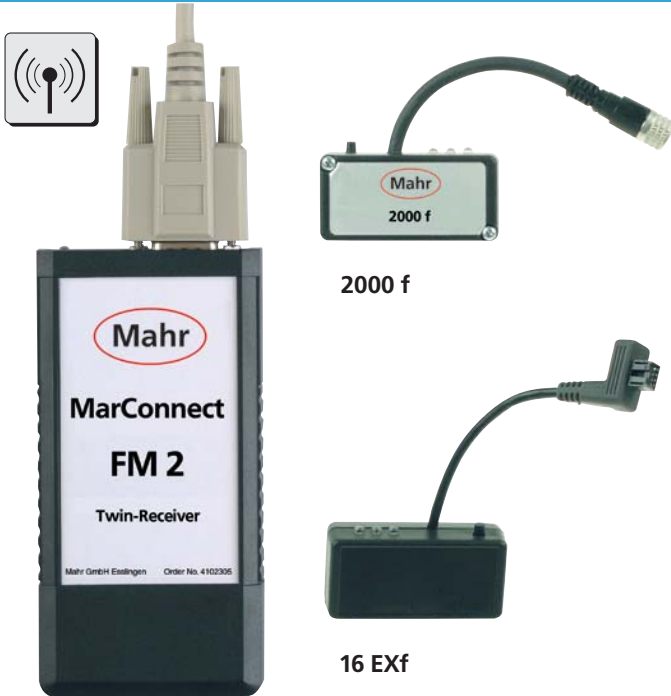

FM 2

FM 2 is not available in North America,
Canada and Mexico

Note:

FM 1 and FM 2 are not compatible with one another.

Features

- Wireless data transmission from a measuring instrument to a PC
- Secure data transmission due to the acknowledgement dialog of the received data from the PC to the measuring instrument
- Optical confirmation of received data on the transmitter
- TWIN receiver for USB and RS232 interfaces
- Compact transmitter without an external antenna
- Theoretically unlimited amount of measuring instruments can be connected to a receiver
- Distance of radio wave up to 100 m (depending on the working environment)
- Radio frequency is 433 MHz*
- Up to 69 channels are available per receiver, several receivers can be used at any one time
- Bi-directional radio link (remote control from measuring instruments)
- Triggering data via a hand switch is possible

* Further frequencies are available upon request

Transmitter

For Measuring Instruments		Order no.
MarCal	16 ER, 16 EWR, 16 EWW, 18 EWR, 30 ER, 30 EWN, 30 EWR	16 EXf 4102306
Digimar	814 SR	
Micromar	40 EW, 44 EX, 46 EX, 40 EWS, 40 EWW	
MarCator	1075, 1080, 1081, 1086, 1087	
MarCal	25 ES, 30 EWD, 31 ES, 32 ES	1082 f 4102307
Digimar	27 ES, M 814	
MarTool	106 ES	
Millimes	2000, 2001, 2100	2000 f 4102309
MarCator	1088	
Digimar	816 CL	
Digimar	817 CLM	817 f 4102310
Millimar	C1208, C1216, C1245, S1840	RS232 f 4102311

Further transmitters are available, see page 11-9

Receiver

	Order no.
TWIN Receiver for USB and RS232 interfaces incl. driver and basic software. Basic software consists of a software keyboard interface and software to store measured values in an MS-Excel® column	FM 2 4102305



Accessories

	Order no.
Hand switch for remote control*	HTF 1 4102314

* only in conjunction with Software Pack Plus

Software

	Order no.
Software Pack Plus to store measured data from several transmitters in separate MS-Excel® columns. Remote control with the hand switch.	4102315

MarConnect. Interfaces



OVERVIEW

Connect to ... Instrument	PC			
	 direct via USB and MarCom Software	 direct via RS232C and MarCom Software	 via Digi-USB 1	via T-Box
Foot Switch	4102058+4102782 ③	4102058+4102782 ②③	-----	4102556
16 ER / EWR 16 EWW 18 EWR 30 ER / EWR / EWN 40 EW, 40 EWS, 40 EWW, 46 EX, 44 EX 1075, 1080, 1081, 1086, 1087 814 SR, PS1, M300	4102357	4102410	4102411	4102411
2000, 2001, 2100 1088, 816 CL	4346023	4346020	4346021	4346021
838 EA, 838 EI (Model A) 838 EA, 838 EI (Model B)	-----	-----	4495083 4495084 ⑥	----- 4495084 ⑥
Maxµm III	-----	-----	2239037	2239037
µMaxµm	2121427	SCB-4	2001025	2001025
25 ES 31 ES, 32 ES 106 ES M 814	4102510+4102330	4102510	-----	4102510
MSP 2	4102711+4102334 ④	4102711 ④	-----	-----
1240, S1840, C1245, C1208, C1216, X1715, X1741	7024634+4102331 ⑤	7024634 ⑤	-----	4102715
Digimar 817 CLM	7024634+4102333 ④	7024634 ④	-----	-----

① Only available in North America, Canada and Mexico
 ② Foot switch; only with an additional USB Port
 ③ Cable length 18 cm / 7"

④ Data transmission only with the "Data" key or "automatic transmission" on the measuring instrument
 ⑤ Foot switch to transfer data on the measuring instrument
 Millimar - Order no. 5330956 / Millimar 1240 - Order no. 5312431

► | **MarConnect.** Regardless of which interface standard you use, whether; USB, Opto RS232 oder Digimatic, MarConnect always provides you with the optimum connection. | ◀

 Transmitter ① FM 1 via USB	 Transmitter FM 2 via USB or RS232	Data printer MSP 2
-----	4102314 ⑦	4102058
4102321	4102306	4102411
2121369	4102309	4346021
Mahr Federal Mahr Federal	----- 4102313+4495084	4495083 4495084 ⑥
2121368 (6 pin only)	-----	2239037
Mahr Federal	4102312	2001025
4102322	4102307	4102510
-----	-----	-----
2121317 ⑧	4102311 ⑧	7024634
2121317	4102310	7024634

Standard cable length 2 m

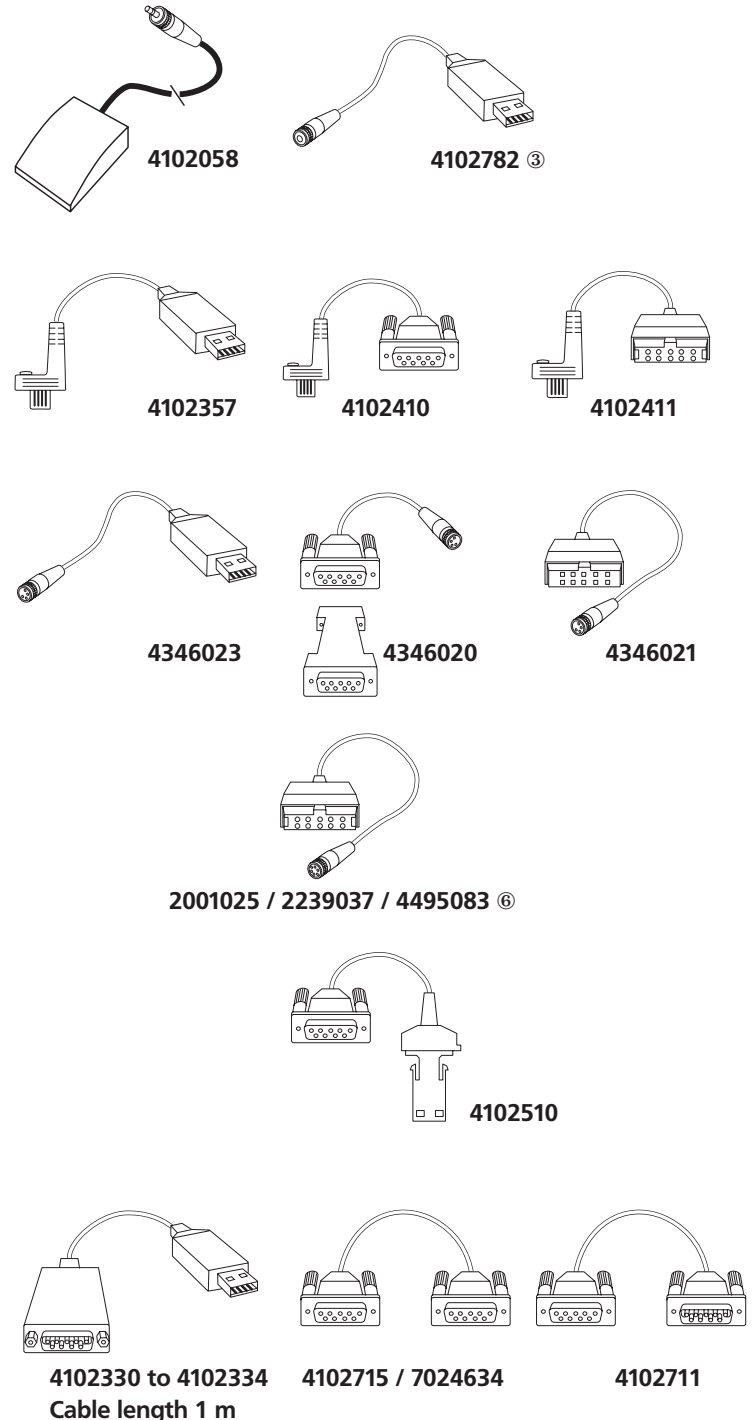

⑥ Data cable is included in the handle of the measuring instrument, cable length 1.5 m / 5 ft
 ⑦ Hand switch only in conjunction with Software pack Plus
 ⑧ Not available for Millimar 1240

THE COMPLETE SUPPORT FOR YOUR INSPECTION. **MARTOOL**



The latest information on MARTOOL products can be found on our website:

www.mahr.com, WebCode 10436-5062

▶ | MarTool measuring and inspection equipment are indispensable aids for dimensional metrology. Their simple handling make them the most versatile instruments for daily use in either the inspection room or the workshop, whether measuring an angle on a work piece or inspecting the surface plate for a height measuring instrument with the outstanding quality from MarTool you cannot go wrong.

▶ | MarTool. Measuring and Inspection Equipment

MarTool 104 Knife-edge Straight Edges	12- 2
MarTool 105 / 105 F /105 Y /105 Z Set Squares	12- 2
MarTool 106 UF / 106 ES Universal Bevel Protractor	12- 4
MarTool 107 AG /107 Us /107 Ug Granite Surface Plates, Accessories	12- 6
MarTool 107 MH / 107 V Magnetic V-Blocks	12- 9

MarTool. Measuring and Inspection Equipment

OVERVIEW STRAIGHT EDGES AND SQUARES



Knife-edge Straight Edge 104 H

Features

- Stainless steel, hardened throughout and ground
- Heat insulators
- One end has a pointed tip
- Supplied with: Carton

Accuracy

according to DIN 874, sheet 2

To determine the straightness tolerance t of the knife edge use the following formula:

$$t = 2 + \frac{l}{250} \mu\text{m}$$

Length l in mm

Technical Data

Length		Cross section mm	Weight kg	Order no.
mm	(inch)			
75	(3")	22 x 6	0.05	4205000
100	(4")	22 x 6	0.07	4205001
125	(5")	22 x 6	0.09	4205002
150	(6")	22 x 6	0.11	4205003
200	(8")	22 x 6	0.15	4205004
300	(12")	30 x 7	0.25	4205005
400	(16")	40 x 7	0.75	4205007
500	(20")	40 x 7	0.91	4205006

Flat Square 105/0

Features

- Hardened stainless steel
- Supplied with: Carton

Accuracy

Grade 0 DIN 875

Technical Data

Length of beams		Cross section mm	Weight kg	Order no.
mm	(inch)			
50 x 40	(2 x 1.6")	14 x 4	0.04	4207008
75 x 50	(3 x 2")	15 x 4	0.05	4207009
100 x 70	(4 x 3")	20 x 5	0.11	4207000
150 x 100	(6 x 4")	25 x 6	0.22	4207001
200 x 130	(8 x 5.1")	30 x 7	0.54	4207002
300 x 200	(12 x 8")	40 x 8	1.12	4207004

Flanged Beam Square 105 F/0

Features

Accuracy

Grade 0 DIN 875

To determine the right angle tolerance t of the test surface use the following formula:

$$t = 5 + \frac{l}{50} \mu\text{m}$$

(Length l is the longer beam in mm)

Technical Data

Length of beams		Cross section	Weight	Order no.
mm	(inch)	mm	kg	
50 x 40	(2 x 1.6")	13.5 x 5	0.05	4208008
75 x 50	(3 x 2")	15 x 4	0.08	4208009
100 x 70	(4 x 3")	20 x 5	0.20	4208000
150 x 100	(6 x 4")	25 x 6	0.46	4208001
200 x 130	(8 x 5.1")	30 x 7	0.75	4208002
300 x 200	(12 x 8")	40 x 8	1.68	4208004

Knife-edge Square 105 Y

Features

- Hardened stainless steel
- Supplied with:
Carton

Accuracy

Grade 00 DIN 875

Technical Data

Length of beams		Cross section	Weight	Order no.
mm	(inch)	mm	kg	
50 x 40	(2 x 1.6")	14 x 4	0.03	4210000
75 x 50	(3 x 2")	16 x 4	0.05	4210001
100 x 70	(4 x 3")	20 x 5	0.10	4210002
150 x 100	(6 x 4")	25 x 6	0.26	4210003
200 x 130	(8 x 5.1")	30 x 7	0.43	4210004
300 x 200	(12 x 8")	40 x 8	0.96	4210005
500 x 330	(20 x 13")	45 x 10	2.20	4210006

Square 105 Z

Features

- Hardened stainless steel
- Precision ground narrow beam and a wide beam
- Without a knife edge
- Supplied with:
Carton

Accuracy

Grade 0 DIN 875

To determine the right angle tolerance t of the test surface use the following formula:

$$t = 5 + \frac{l}{50} \mu\text{m}$$

(Length l is the longer beam in mm)

Technical Data

Length of beams		Cross section		Weight	Order no.
mm	(inch)	narrow beam mm	wide beam mm	kg	
50 x 40	(2 x 1.6")	16 x 2	14 x 10	0.05	4211005
75 x 50	(3 x 2")	16 x 2	14 x 10	0.06	4211000
100 x 70	(4 x 3")	20 x 3	18 x 12	0.13	4211001
150 x 100	(6 x 4")	26 x 3	24 x 14	0.32	4211002
200 x 130	(8 x 5.1")	30 x 4	28 x 16	0.75	4211003
300 x 200	(12 x 8")	40 x 6	38 x 20	1.60	4211004

Universal Bevel Protractor 106 UF



Features

- With fine adjustment
- Stainless steel
- Vernier scale and main scale both have a satin chrome finish to prevent glare and to enable parallax free reading on the same plane
- Knurled screw for clamping the interchangeable beam into position
- Supplied with: Magnifying reading lens, interchangeable beam and case

Technical Data

Blade length mm	Range degrees	Readings minutes	Deviation minutes	Order no.
150	360°	5'	5'	4214050
200	360°	5'	5'	4214051
300	360°	5'	5'	4214052

Accessories

	Order no.
Interchangeable Beams Stainless steel, hardened (standard accessories) beam length	106 Us
150 mm / 6"	4214010
200 mm / 8"	4214011
300 mm / 12"	4214012
Additional Accessories	
Stand Featuring flat and V-surface for dia. 5 – 30 mm length 90 mm, width 25 mm	106 UFv
	4214061
Acute Angle Attachment for particularly small acute angles, screws onto the beam	106 UFw
	4214062

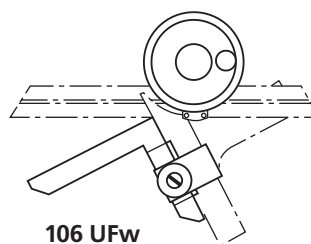
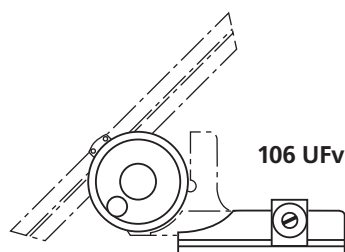

Digital Universal Bevel Protractor 106 ES



Features

- Easy to read high contrast 8,5 mm high LCD
- Displays the angular degrees and angular minutes or decimal degrees
- Zero setting at any position of the measuring range
- Beam can be damped with a push button
- Fine adjustment for easy setting of a desired angle
- Locking lever to prevent accidental adjustment
- Base plate and beam are made of stainless steel, the measuring edges hardened
- Data output: Opto RS232C
- Max. setting speed 3 rotations per second
- Capacitive measuring system, life of the battery ca. 2 years
- Supplied with: Battery, 300 mm beam and case

Technical Data

Range	Resolution switchable	Deviation	Order no.
1 x 360° or 2 x 180° or 4 x 90°	1 minutes or 0.01°	± 2 minutes	4214600

Accessories

	Order no.
Interchangeable Beams Stainless steel, hardened beam length	106 ESs
150 mm / 6"	4214620
200 mm / 8"	4214621
300 mm / 12"	4214622
Battery 3V , Type CR 2032	4102520
Data Connection Cable Opto RS232C (2 m), with SUB-D Jack 9 pin	16 ESv 4102510
Stand Featuring flat and V-surface for dia. 5 – 30 mm, length 90 mm, width 25 mm	106 ESv 4214630
Acute Angle Attachment for particularly small acute angles, screws onto the beam	106 UFw 4214062

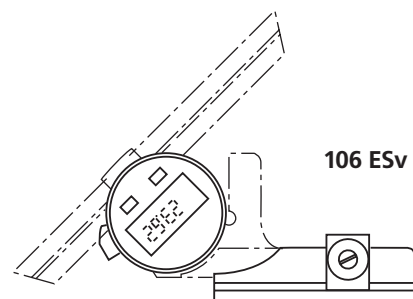

Surface Plate 107 G made from granite



Features

- For measuring tasks, layout work, for touching up and lapping precision parts
- Made of choice fine-grain black granite (Diabas)
- High density structure thus extremely homogeneous
- Hardness 6-7 on the Mohs' hardness scale
- Surface plate is lapped and has a satin matt finish to prevent glare
- 100 % corrosion-proof
- Non-magnetic and non-conductive
- Measuring instruments and test equipment are easy to slide over surface

Technical Data

Size of plates mm	Thickness of plate mm	Weight kg	Order no.*		
			Grade 00 DIN 876	0 DIN 876	1 DIN 876
400 x 250	60	18	4221500	4221520	4221540
400 x 400	60	29	4221501	4221521	4221541
630 x 400	80	60	4221502	4221522	4221542
630 x 630	80	95	4221503	4221523	4221543
800 x 500	100	120	4221504	4221524	4221544
1000 x 630	100	190	4221505	4221525	4221545
1200 x 800	150	432	4221506	4221526	4221546
1500 x 1000	150	675	4221507	4221527	4221547
2000 x 1000	200	1200	4221508	4221528	4221548

Flatness tolerance t_f of the surface plate are derived from the following formulas:

Grade acc to DIN 876	Flatness tolerance in μm
00	$t_f = 2 (1 + l/1000)$
0	$t_f = 4 (1 + l/1000)$
1	$t_f = 10 (1 + l/1000)$

Length l in mm

Surface plates are available in other dimensions upon request

* Excludes stand with cabinet

Mounting of Surface Plates 107 G up to 2000 x 1000 mm

Distortion of the surface plates is minimized if supported at the support points A.
 For plates with edge lengths over 1000 mm it is advised to provide anti-tilt elements at the B support points.
 Support points A (Bessel points, $0.22 \times l$ or w from the edge of the plate). Support points B are for the anti-tilt elements.

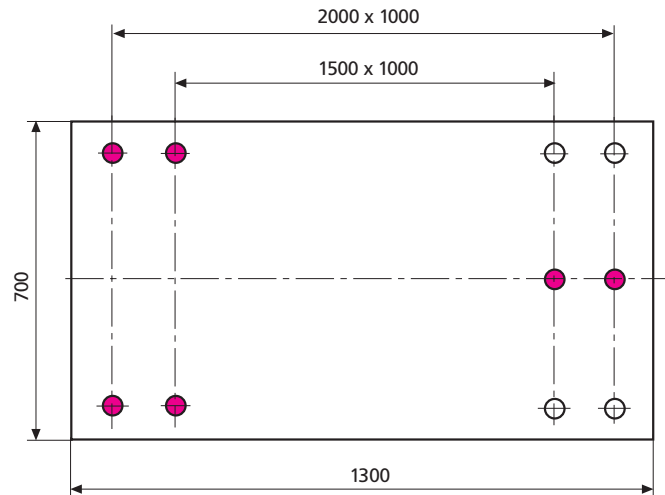
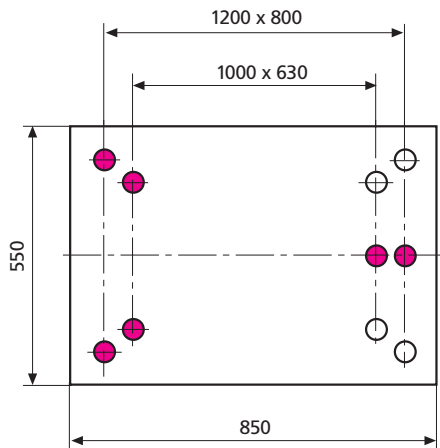

● Support point A

○ Support point B

Accessories

Adjustable Plate Supports 107 Asa

For mounting the surface plates upon work benches or cabinets; three are for support and two to prevent tilting

Quantity

Order no.

1 piece

4221069

Stand with Cabinet 107 Us



Features

- Extremely sturdy design due to the rectangular tubes, covered with sheet metal
- With three height adjustable supports
- For plates sizes that are greater than 1000 mm, two additional height adjustable supports are required to prevent tilting
- All 4 corners have a support to prevent slipping and to protect against a collision
- Doors can be locked

Technical Data

For plate sizes mm	Height mm	Order no.*
630 x 400	900 - 1000	4221560
630 x 630		4221561
800 x 500		4221562
1000 x 630		4221563
1200 x 800		4221564
1500 x 1000		4221565
2000 x 1000		4221566

* Excludes surface plate

Stand 107 Ug



Features

- Extremely sturdy design due to the rectangular tubes
- With three height adjustable supports
- For plates sizes that are greater than 1000 mm, two additional height adjustable supports are required to prevent tilting
- All 4 corners have a support to prevent slipping and to protect against a collision

Technical Data

For plate sizes mm	Height mm	Order no.*
630 x 400	900 - 1000	4221570
630 x 630		4221571
800 x 500		4221572
1000 x 630		4221573
1200 x 800		4221574
1500 x 1000		4221575
2000 x 1000		4221576

* Excludes surface plate

Magnetic V-Blocks 107 MH



Features

- To used in an inspection room and workshop for both measuring and scribing
- To clamp work pieces during drilling, grinding and light milling work
- Integrated magnetic system, protected against the intrusion of moisture
- Constant magnetic force
- With the switch the upper, lower and opposite face are all simultaneously magnetized
- Surfaces and measuring faces and both hardened and ground
- Available individually or as a matched pair

Technical Data

Accuracy (deviation):	
Flatness and parallelism	≤5 μm
Angle between front and side faces respectively the V-slots	≤5 μm
Symmetry of the V-slots	≤5 μm
Height difference of the V-slots of pairs	≤5 μm
Length x Width x Height	100 x 70 x 95 mm
For shaft dia.	5 - 65 mm
V-angle	90°
Weight per piece	4 kg
Magnetic force on a flat surface	≈1000 N (100 kp)
Magnetic force of V-block	≈750 N (75 kp)
Order no. V-block	4230000
Order no. pair of V-blocks	4230001

Accessories

	Order no.
Wooden case (for 1 V-block)	4230005

V-Block 107 V



Features

- For testing of small cylindrical work pieces for there ovality and polygon error
- With 108° V-slot
- Made from special hardened and ground steel
- Available individually or as a matched pair

Technical Data

Accuracy (deviation):	
Parallelism of the V-slot to the underside of the base	≤2 μm
Height difference of the V-slots of pairs	≤5 μm
Length x Width x Height	30 x 30 x 30 mm
For shaft dia.	2 - 25 mm
V-angle	108°
Weight per piece	0.2 kg
Order no. V-block	4229000
Order no. pair of V-blocks	4229001

MADE TO MEASURE. MARGAGE



The latest information on MARGAGE products can be found on our website:

www.mahr.com, WebCode 10397

▶ | In 1871, at the foundation of the German Empire and during the introduction of the metric system, Mahr was already supplying dimensional standards to the weights and measurement office of several individual German states. Today, the measurement standards such as gage blocks are the basis of dimensional metrology, they are used as a setting standard for an indicating measuring instrument or applied in the calibration laboratory as a reference standard. Due to our accreditation from the PTB - Physikalisch-Technischen Bundesanstalt (German metrology institute providing scientific and technical services) and the careful selection of the materials we use, we can grant you the highest possible quality! | ◀

▶ | MarGage. Standards, Gages and Gage Blocks

Rectangular Gage Blocks	13- 2
according to DIN EN ISO 3650	
MarGage 402 / 404 / 406 / 408 / 409	13- 4
Rectangular Gage Blocks made of steel	
MarGage 411 / 415	13- 4
Test Sets for Calipers	
MarGage 417	13- 4
Individual Rectangular Gage Blocks made of steel	
MarGage 402C / 404C / 406C / 408C / 409C	13- 5
Rectangular Gage Blocks made of ceramic	
MarGage 417C	13- 7
Individual Rectangular Gage Blocks made of ceramic	
MarGage 418C	13- 7
Protective Rectangular Gage Blocks made of ceramic	
MarGage 419C	13- 7
Test Sets for Micrometers	
Accessories for Rectangular Gage Blocks	13- 8
Inch Gage Blocks	13-10
according to ANSI	
Pin Gages	13-12
MarGage 426 / 426 G / 426 S / 426 D / 426 DS / 426 M / 426 A	13-12
Pin Gages made of steel	
Settings Standards / Thread Gages	13-16
AGD Masters	13-16
Master Rings / Master Discs / Master Plugs	
MarGage 355 E / 390 / 708 E / 715 E	13-17
Setting Standards	
MarGage 705 / 708 G / 708 N / 715 G / 715 N / 716 G / 716 N	13-18
Thread Gages	

MarGage. Standards, Gages and Gage Blocks

RECTANGULAR GAGES BLOCKS

Application

- As comparison reference and utilization standards in the field of length measurement
- For checking gages and measuring instruments
- For setting devices of all types designed for length measurement and in particular their displays
- Can be used individually or in combinations by wringing several blocks together (see illustration)

Accuracy

The manufacturing process is based on DIN EN ISO 3650, Mahr gage blocks are produced with the utmost care.

Marking

Gage blocks of all grades are clearly and individually marked with an identification number.

Material

Mahr gage blocks are made either of stainless steel or of the ceramic compound zirconium oxide ZrO_2 (Circonimar).

Heat Expansion Coefficient

Steel	$11.5 \times 10^{-6} K^{-1}$
Circonimar	$9.5 \times 10^{-6} K^{-1}$

Calibration Certificate

Gage blocks in sets are supplied with a Mahr calibration certificate stating deviations from the nominal size, this confirms the traceability to National Standards.
 For single gage blocks Mahr calibration certificates are available on request.
 A calibration certificate from the Mahr DKD Calibration Laboratory is recommended for gage blocks of calibration grade K in the range between 0.5 and 100 mm

Dimensions

	Nominal dimension mm	Cross section mm
from	0.5 - 10	30 x 9
over	10 - 1000	35 x 9



DEUTSCHER KALIBRIERDIENST



GERMAN CALIBRATION SERVICE
 Calibration Laboratory for Length
 Measurement
 ACCREDITED BY THE PHYSIKALISCH-
 TECHNISCHE BUNDESANSTALT (PTB)

As a part of the German Calibration Service, the Mahr Calibration Laboratory calibrates steel and ceramic gage blocks of all brands in the range between 0.5 and 100 mm and issues calibration certificates. The gage block sets are marked with the official DKD calibration label. Calibration is based on the contract concluded between the Physikalisch-Technischen Bundesanstalt in Braunschweig and the company Mahr.

Selection of Rectangular Gage Block Sets

There are three criteria's to be considered:

1 Calibration and Tolerance classes according to DIN EN ISO 3650

Four tolerance classes are available.

Calibration class K

As primary factory standard, particularly for the calibration of subsidiary test laboratories, e.g. for gage blocks of lower tolerance classes. Supplied on request with DKD calibration certificate, indicating the deviation from the nominal size for each gage block.

Calibration class 0

For maximum accuracy requirements. To be used as basic standards in test laboratories and precision inspection rooms, where other gage blocks and high accuracy measuring instruments are calibrated.

Tolerance class 1

For high standards of accuracy. As reference gage block for the inspection room. Designed to perform particularly accurate measurements. For setting indicating measuring instruments and for checking precision gages.

Tolerance class 2

For checking production gages of quality IT 6 and IT 7. For setting indicating measuring instruments and for checking accurate dimensions in the jig and tool industry.



404

2 Material

Steel or ceramic, depending on application.

3 Size of Sets

The gage block sets 404 or 404 C are very convenient, each set contains 46 gage blocks including one for each decimal. Larger sets are particularly suited to inspection rooms and gage testing facilities, since they offer the following advantages:

- A required dimension can be made up quicker as fewer gage blocks are needed
- Several gage block combinations can be formed from the same dimension
- Greater accuracy as individual deviations add up to smaller overall error
- Less wear as a given gage block is not used as often

Rectangular Gage Blocks made of Steel

Sets

- Vertical arrangement to save space
- Scope of supply: wooden case with clear labeling strips, Mahr calibration certificate (see Page 13-2)
- See the following table for nominal sizes, increments and tolerance classes:

Catalog no.	Tolerance class	Order no.	Quantity per set	Nominal sizes mm	Increments mm	Gage blocks
402/K	K	4800403	32	1.005	-	1
402/0	0	4800400		1.01 - 1.09	0.01	9
402/1	1	4800401		1.1 - 1.9	0.1	9
402/2	2	4800402		1 - 9	1	9
				10 - 30	10	3
				50	-	1
404/K	K	4800003	46	1.001 - 1.009	0.001	9
404/0	0	4800000		1.01 - 1.09	0.01	9
404/1	1	4800001		1.1 - 1.9	0.1	9
404/2	2	4800002		1 - 9	1	9
				10 - 100	10	10
406/K	K	4800014	87	0.5	-	1
406/0	0	4800010		1.001 - 1.009	0.001	9
406/1	1	4800011		1.01 - 1.49	0.01	49
406/2	2	4800012		1 - 9.5	0.5	18
				10 - 100	10	10
408/K	K	4800027	111	0.5	-	1
408/0	0	4800020		1.001 - 1.009	0.001	9
408/1	1	4800021		1.01 - 1.49	0.01	49
408/2	2	4800022		1 - 24.5	0.5	48
				25 - 100	25	4
409/K	K	4800033	121	0.5	-	1
409/0	0	4800030		1.001 - 1.009	0.001	9
409/1	1	4800031		1.01 - 1.49	0.01	49
409/2	2	4800032		1.6 - 1.9	0.1	4
				1 - 24.5	0.5	48
				25, 30, 40, 50, 60, 70, 75, 80, 90, 100		10

Test Sets for Calipers

Catalog no.	Tolerance class	Order no.	Quantity per set	Nominal sizes mm
411/1	1	4800343	5	30 / 41.3 / 131.4 / 243.5 / 281.2
411/2	2	4800344	5	30 / 41.3 / 131.4 / 243.5 / 281.2
415/1	1	4800339	6	30 / 41.3 / 131.4 / 243.5 / 281.2 / 481.1
415/2	2	4800340	6	30 / 41.3 / 131.4 / 243.5 / 281.2 / 481.1

Individual Rectangular Gage Blocks 417

- Tolerance classes K, 0, 1, 2
- From nominal dimension of greater than 125 mm, gage blocks are supplied in a wooden case
- Special sizes are available on request

	Nominal sizes mm	Increments mm
	0.5 - 1	0.05
over	1 - 100	same a set 409
	125 - 200	25
	250 - 500	50
	600 - 1000	100

Rectangular Gage Blocks made of Ceramic

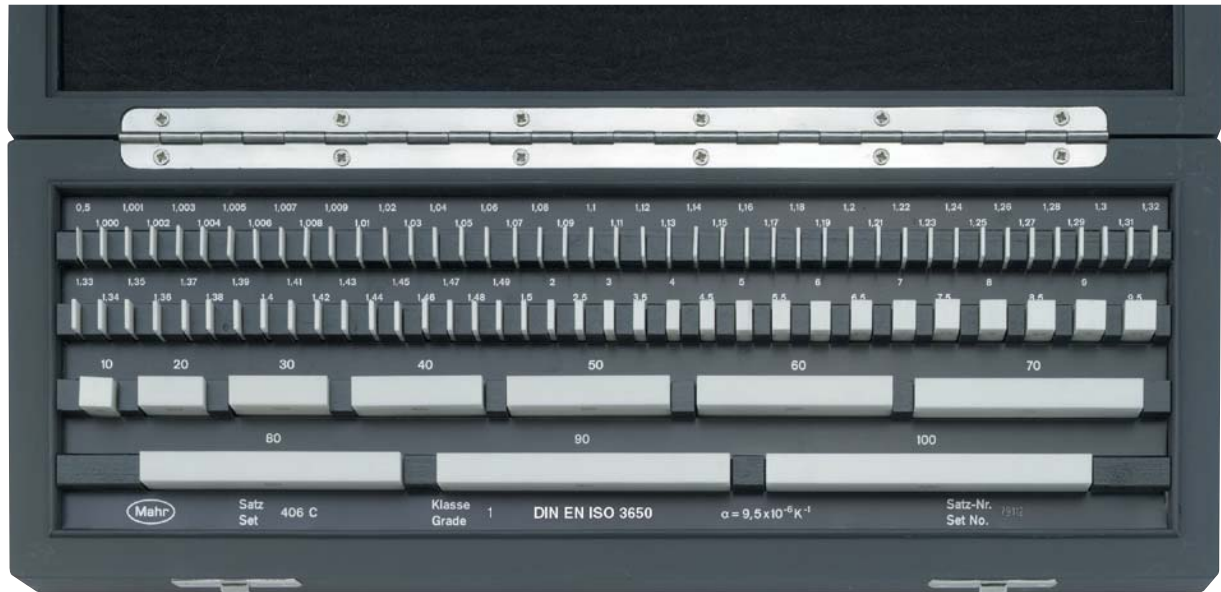

406 C

Features

- Resistant to both impact and breakage. Virtually no warping of material if surfaces become scratched or edges damaged. Longer retention of wringing ability
- Extremely durable, thus providing a long service life as well being highly robust compared to all other materials currently be used in metrology. Therefore the interval between inspections are distinctly greater
- The corrosion-resistant Circonimar is even without protective measures extremely resistant to alkalis, acids, oil, grinding fluid and other aggressive media
- Similar coefficient of expansion to steel, thus allowing unrestricted use even at unfavorable temperatures
- Non-magnetic Circonimar is anti-static, anti-magnetic and non-conductive. It does not attract dust or dirt and is suitable to use in the presence of magnetic fields
- Ideal for all applications. The outstanding features of all ceramic gage blocks from Mahr provide unrivalled flexibility in practical use. Circonimar is equally well suited to inspection-room conditions and the rigors of workshop applications
- Easy to handle. No material is easier to handle than Circonimar; Circonimar has excellent wringing properties, no corrosion, no need for lubrication, low weight and scratch resistant

Rectangular Gage Blocks made of Ceramic

Sets

- Vertical arrangement to save space
- Scope of supply: wooden case with clear labeling strips, Mahr calibration certificate (see Page 13-2)

Nominal sizes, increments and tolerance classes

Please refer to the table below:

Catalog no.	Tolerance class	Order no.	Quantity per set	Nominal sizes mm	Increments mm	Gage blocks
402 C/K	K	4800094	32	1.005	-	1
402 C/0	0	4800095		1.01 - 1.09	0.01	9
402 C/1	1	4800096		1.1 - 1.9	0.1	9
402 C/2	2	4800097		1 - 9	1	9
				10 - 30	10	3
				50	-	1
404 C/K	K	4800088	46	1.001 - 1.009	0.001	9
404 C/0	0	4800008		1.01 - 1.09	0.01	9
404 C/1	1	4800009		1.1 - 1.9	0.1	9
404 C/2	2	4800004		1 - 9	1	9
				10 - 100	10	10
406 C/K	K	4800016	87	0.5	-	1
406 C/0	0	4800018		1.001 - 1.009	0.001	9
406 C/1	1	4800019		1.01 - 1.49	0.01	49
406 C/2	2	4800017		1 - 9.5	0.5	18
				10 - 100	10	10
408 C/K	K	4800025	111	0.5	-	1
408 C/0	0	4800028		1.001 - 1.009	0.001	9
408 C/1	1	4800029		1.01 - 1.49	0.01	49
408 C/2	2	4800026		1 - 24.5	0.5	48
				25 - 100	25	4
409 C/K	K	4800036	121	0.5	-	1
409 C/0	0	4800038		1.001 - 1.009	0.001	9
409 C/1	1	4800039		1.01 - 1.49	0.01	49
409 C/2	2	4800037		1.6 - 1.9	0.1	4
				1 - 24.5	0.5	48
				25, 30, 40, 50, 60, 70, 75, 80, 90, 100		

Individual Rectangular Gage Blocks 417 C

- Tolerance classes K, 0, 1, 2
- Special sizes are available on request

Nominal sizes mm	Increments mm
0.5	-
1	-
1.0005	-
1.001 - 1.009	0.001
1.01 - 1.5	0.01
1.6 - 2.0	0.1
2.5 - 25.0	0.5
30 - 100	10

Pair of Protective Rectangular Gage Blocks 418 C

Catalog no.	Tolerance class	Order no.	Quantity per set	Nominal sizes mm	Increments mm	Gage blocks
418 C/0	0	4800085	2	2	-	2
418 C/1	1	4800086	2	2	-	2

Test Set for Micrometers 419 C (DIN 863)

Catalog no.	Tolerance class	Order no.	Quantity per set	Nominal sizes mm
419 C/1	1	4800090	10	2.5 / 5.1 / 7.7 / 10.3 / 12.9 / 15.0 / 17.6 / 20.2 / 22.8 / 25 plus 1 optical parallel dia. 30 mm

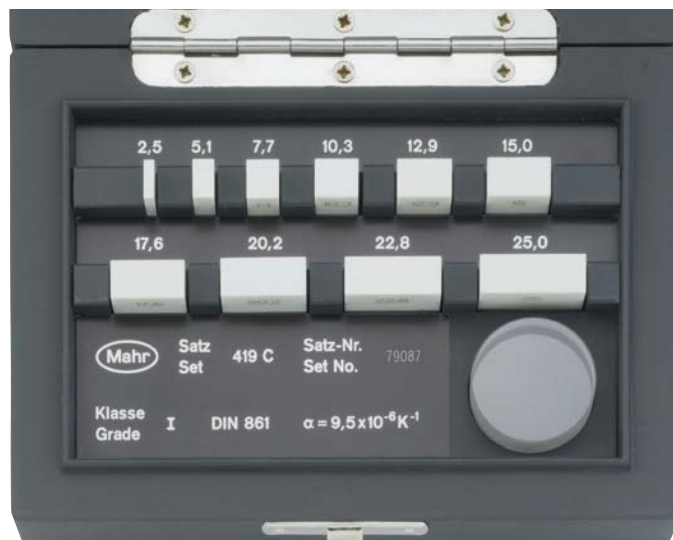

Accessories for Rectangular Gage Blocks



Rectangular Gage Block Holder and Measuring Jaws Accessory Set 420

- To be used in conjunction with Gage Blocks for gaging both work pieces and fixtures
- To check, set and adjust setting gages and measuring instruments
- For scribing and marking
- Supplied with:
Wooden case

Order no. **4800100**

Components include:

- 2 Pairs of Measuring Jaws 420 m
- 1 Scriber Point 420 a
- 1 Centering Point 420 z
- 3 Holder 420 h for Gages Blocks
clamping width 0-70, 0-120, 100-220 mm
- 1 Stand 420 f for Gage Block Holder

Individual Accessories

Components included in the 420 set are also individually available:

Measuring Jaws 420 m

Cross section 9 x 9 mm

For internal and external measurements in conjunction with a Gage Block Holder 420 h and Gage Blocks

Thickness mm	Order no.
2 x 2 mm = 4 mm	4800110
2 x 5 mm = 10 mm	4800111

Scriber Point 420 a cross section 9 x 9 mm

Order no. **4800112**

Centering Point 420 z cross section 9 x 9 mm

Order no. **4800113**

Holder 420 h for Rectangular Gage Blocks

Clamping width mm	Order no.
0 - 70	4800120
0 - 120	4800121
100 - 220	4800122
100 - 420	4800123
400 - 820	4800124

Stand 420 f for Holder 420 h*

Hardened and lapped. Height 25 mm
Tolerance $\pm 2 \mu\text{m}$

Order no. **4800114**

* Clamping width up to 420 mm

Optical Flat 421

- To test the surface flatness on precision components or measuring instruments according to the interference principle
- Supplied with:
Wooden case



Dia. mm	Thickness mm	Flatness deviation μm	Order no.
45	11	≤ 0.1	4800140
100	20	≤ 0.1	4800135
150	30	≤ 0.1	4800136
300	50	≤ 0.4	4800137

Optical Parallel 421 P

Dia. mm	Thickness mm	Flatness deviation μm	Parallelism deviation μm	Order no.
30	12	≤ 0.15	0.4	4800180

Contact Thermometer 422



- For checking/taking the temperature
- With silver contact base, gold-plated to prevent tarnishing
- With a holding magnet to be attached to the thermometer in vertical or on inclined surfaces
- U-shaped with clamping screw
- Supplied with:
Thermometer, magnet and wooden case

Readings 0.2°C
Measuring range 16-26°C

Order no. 4800170

Wooden Tongs 423

- To prevent heat transfer when handling gage blocks
- Self closing. See illustration below.

Order no. 4800142

Maintenance Set 424

- The most important equipment for inspecting and maintaining gage blocks
- Supplied with: Wooden case

Order no. 4800130



Components include:

Optical Flat 421

- To test the surface flatness of measuring surfaces according to the interference principle. Diameter 45 mm

Wooden Tongs 423

- To prevent heat transfer when handling gage block, self closing

Granite lapping stone

- To remove burr and other damage on surfaces of gage blocks. High accuracy version

Jar of special Vaseline

- To protect steel gage blocks against the rust

Brush and suede cloth

- To clean the gage blocks

Inch Gage Blocks

Features

- Long used as the practical standards of dimensional measurement in precision manufacturing. With accuracies, materials and manufacturing methods greatly refined, gage blocks are now of highest quality and precision.
 - As comparison reference and utilization standards in the field of length measurement.
 - For checking gages and measuring instruments.
 - Used individually or in combinations by wringing several blocks together.
- Mahr Federal gage blocks are available from stock individually and as full sets in inch (rectangular only).
- Sets are manufactured to Grade **0** only, which meet or exceed ASME B89.1.9-2002 specifications.
- Offered in steel to suit a wide range of service conditions. Steel blocks are extremely stable, hardened to Rc 62 minimum, and processed through a thorough seasoning cycle to relieve internal stresses before finish lapping.
- All sets blocks are serialized and supplied in a fitted storage case. Certification priced separately.



Mahr Federal Calibration System is certified to ISO-17025 and accredited by NVLAP and ISO-9001 certified by NQA

Technical Data

Dimensions – Standard Size Blocks

Block Style	Gaging Length	Width mm / <i>inch</i>	Depth mm / <i>inch</i>
Inch – Rectangular	.400" or less	30 / 1.181"	9 / .352"
	.400" and over	35 / 1.378"	9 / .352"

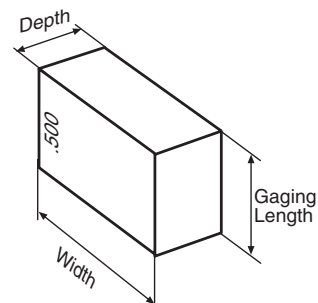

Inch Gage Blocks Set

Ordering Information

Inch Rectangular

An 81 block set containing

Series	Number of blocks	Size
.0001"	9	.1001 - .1009
.001"	49	.101 - .149
.050"	19	.050 - .950
1.000"	4	1.000 - 4.000

Order No. 2176361

Inch Rectangular

An 49 block set containing

Series	Number of blocks	Size
.0001"	9	.1001 - 1.009
.001"	9	.101 - .109
.01"	9	.010 - .090
.01"	9	.110 - .190
.10"	9	.100 - .900
1.000"	4	1.000 - 4.000

Order No. 2176362



Technical Data

Grade 0 Length Tolerances

Nominal Length

Greater than	Less than or equal to	Unit 0.000001" (1 μinch)
0	0.4	± 5
0.4	1	± 6
1	2	± 8
2	3	± 10
3	4	± 12

Pin Gages 426 according to DIN 2269



Features

- To be used as setting standards for indicating measuring instruments, testing the distances between axes, tapers and other work pieces in conjunction with gage blocks. Can also be used for determining pitch diameter of threads or pitch circle diameter on gears and serrations

Pin Gages 426 made from steel, without a handle from dia. 5.01 mm inscribed with diameter on the end face

Ø mm	mm	Wear-resistant gage steel, hardened, multi-aged, ground and lapped Grade 0, DIN 2269 Manufacturing tolerance ± 0.5 µm		Wear-resistant gage steel, hardened, multi-aged, ground and lapped Grade 1, DIN 2269 Manufacturing tolerance ± 1.0 µm		Wear-resistant gage steel, hardened, multi-aged and precision ground Better than Grade 2, DIN 2269 Manufacturing tolerance ± 1.5 µm		
		Length	Increments	Length	Increments	Length	Increments	
		0.01 mm	0.001 mm	mm	0.01 mm	0.001 mm	mm	
		Order no.	Order no.	Order no.	Order no.	Order no.	Order no.	
0.06 - 0.09	20	4828100	4828300	20	4828110	4828310	20	4828130
0.10 - 0.19	32	4828101	4828301	32	4828111	4828311	40	4828131
0.20 - 0.29	32	4828102	4828302	32	4828112	4828312	40	4828132
0.30 - 0.49	32	4828103	4828303	32	4828113	4828313	40	4828133
0.50 - 0.99	32	4828104	4828304	32	4828114	4828314	40	4828134
1.00 - 2.99	32	4828105	4828305	32	4828115	4828315	40	4828135
3.00 - 5.99	40	4828106	4828306	40	4828116	4828316	***	4828136
6.00 - 9.99	50	4828107*	4828307*	50	4828117	4828317	70	4828137
10.00 - 11.99				70**	4828118	4828318	70	4828138
12.00 - 13.99				70	4828119	4828319	70	4828139
14.00 - 15.99				70	4828120	4828320	70	4828140
16.00 - 18.99				70	4828121	4828321	70	4828141
19.00 - 20.00				70	4828122	4828322	70	4828142

* applies up to dia. 10 mm

** dia. 10 mm = 50 mm long

*** dia. 3 - 4 mm = 50 mm long,
> 4 - 5 mm = 60 mm long,
> 5 mm = 70 mm long

Pin Gages 426 G made from steel, with a handle

Ø mm	mm	Wear-resistant gage steel, hardened, multi-aged, ground and lapped Grade 0, DIN 2269 Manufacturing tolerance ± 0.5 µm		Wear-resistant gage steel, hardened, multi-aged, ground and lapped Grade 1, DIN 2269 Manufacturing tolerance ± 1.0 µm		Wear-resistant gage steel, hardened, multi-aged and precision ground Better than Grade 2, DIN 2269 Manufacturing tolerance ± 1.5 µm		
		Effective Length	Increments	Effective Length	Increments	Effective Length	Increments	
		0.01 mm	0.001 mm	mm	0.01 mm	0.001 mm	mm	
		Order no.	Order no.	Order no.	Order no.	Order no.	Order no.	
0.06 - 0.09	10	4828150	4828350	10	4828160	4828360	10	4828170
0.10 - 0.19	25	4828151	4828351	25	4828161	4828361	33	4828171
0.20 - 0.29	25	4828152	4828352	25	4828162	4828362	33	4828172
0.30 - 0.49	25	4828153	4828353	25	4828163	4828363	33	4828173
0.50 - 0.99	25	4828154	4828354	25	4828164	4828364	33	4828174
1.00 - 2.99	25	4828155	4828355	25	4828165	4828365	33	4828175
3.00 - 5.99	25	4828156	4828356	25	4828166	4828366	***	4828176
6,00 - 10,00	42*	4828157	4828357	42**	4828167	4828367	62	4828177

* dia. 6 mm = 25 mm long

** dia. 6 mm = 25 mm long

*** Ø 3 - 4 mm = 43 mm long,
> 4 - 5 mm = 53 mm long,
> 5 mm = 62 mm long

Length of handle see Page 13-12 (426 D)

Accessories

Wooden case with plastic inlay for pin gages up to D = 10 mm

Number of pin gages

Order no.

max. 50 Pin gages (without handle)

4827609

max. 50 Pin gages (with handle)

4827610

max. 100 Pin gages (without handle)

4827611

Pin Gage sets 426 S made of steel, without a handle in a high quality wooden box with pedestral



Technical Data

Wear-resistant gage steel, hardened, multi-aged, ground and **lapped**
Grade 0, DIN 2269
Manufacturing tolerance $\pm 0.5 \mu\text{m}$

Wear-resistant gage steel, hardened, multi-aged, ground and **lapped**
Grade 1, DIN 2269
Manufacturing tolerance $\pm 1.0 \mu\text{m}$

Wear-resistant gage steel, hardened, multi-aged and precision ground **Better** than Grade 2, DIN 2269
Manufacturing tolerance $\pm 1.5 \mu\text{m}$

\varnothing mm	Increments	Quantity	Order no.	Increments	Quantity	Order no.	Increments	Quantity	Order no.
1.00 - 10.00	0.1	91	4828190	0.1	91	4828210			
0.10 - 0.50	0.01	41	4828181	0.01	41	4828191	0.01	41	4828211
0.50 - 1.00	0.01	51	4828182	0.01	51	4828192	0.01	51	4828212
0.10 - 1.00	0.01	91	4828183	0.01	91	4828193	0.01	91	4828213
1.00 - 2.00	0.01	101	4828184	0.01	101	4828194	0.01	101	4828214
2.00 - 3.00	0.01	101	4828195	0.01	101	4828215			
3.00 - 4.00	0.01	101	4828196	0.01	101	4828216			
4.00 - 5.00	0.01	101	4828197	0.01	101	4828217			
5.00 - 6.00	0.01	101	4828198	0.01	101	4828218			
6.00 - 7.00	0.01	101	4828199	0.01	101	4828219			
7.00 - 8.00	0.01	101	4828200	0.01	101	4828220			
8.00 - 9.00	0.01	101	4828201	0.01	101	4828221			
9.00 - 10.00	0.01	101	4828202	0.01	101	4828222			

Pin gage lengths are the same as the individual pin gages

Individual Plug Gages 426 D made from steel, with a handle



Features

- For testing diameters of small bores
- To be used as setting standards for indicating measuring instruments, testing the distances between axes, grooves and slots on work pieces in conjunction with gage blocks
- Unbreakable plastic handle inscribed with the diameter
- Set with pin gages in diameter increments of 0.01 mm
Manufacturing tolerance $\pm 0.5 \mu\text{m}$
- Supplied with:
Wooden case with plastic inlay

Technical Data

Wear-resistant gage steel, hardened, multi-aged, ground and **lapped**
plastic handle inscribed with the diameter
Manufacturing tolerance $\pm 0.5 \mu\text{m}$
Increment 0.01 mm

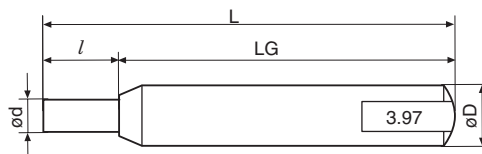

Dimensions

dia. d mm	Order no.	dia. d mm	l mm	dia. D	LG	L
0.06 - 0.09	4828230	0.06 - 0.30	2.0	4	32	34
0.10 - 0.19	4828231	> 0.30 - 0.50	3.5	4	32	35.5
0.20 - 0.29	4828232	> 0.50 - 1.50	5.0	4	32	37
0.30 - 0.49	4828233	> 1.50 - 2.00	6.0	4	32	38
0.50 - 0.99	4828234	> 2.00 - 3.50	8.0	5	35	43
1.00 - 2.99	4828235	> 3.50 - 6.00	10.0	5	45	55
3.00 - 5.99	4828236	> 6.00 - 8.00	14.0	10	45	59
6.00 - 10.00	4828237	> 8.00 - 10.00	18.0	10	45	63

Plug Gage Sets 426 DS made from steel, with a handle in a high quality wooden box with pedestral

Technical Data

Wear-resistant gage steel, hardened, multi-aged, ground and **lapped**
plastic handle inscribed with the diameter
Manufacturing tolerance $\pm 0.5 \mu\text{m}$

dia. mm	Increment	Quantity	Length	Order no.	dia. mm	Increment	Quantity	Length	Order no.
0.06 - 0.50	0.01	45	2*	4825000	5.01 - 5.50	0.01	50	10	4825010
0.51 - 1.00	0.01	50	5	4825001	5.51 - 6.00	0.01	50	10	4825011
1.01 - 1.50	0.01	50	5	4825002	6.01 - 6.50	0.01	50	14	4825703
1.51 - 2.00	0.01	50	6	4825003	6.51 - 7.00	0.01	50	14	4825704
2.01 - 2.50	0.01	50	8	4825004	7.01 - 7.50	0.01	50	14	4825705
2.51 - 3.00	0.01	50	8	4825005	7.51 - 8.00	0.01	50	14	4825706
3.01 - 3.50	0.01	50	8	4825006	8.01 - 8.50	0.01	50	18	4825707
3.51 - 4.00	0.01	50	10	4825007	8.51 - 9.00	0.01	50	18	4825708
4.01 - 4.50	0.01	50	10	4825008	9.01 - 9.50	0.01	50	18	4825709
4.51 - 5.00	0.01	50	10	4825009	9.51 - 10.00	0.01	50	18	4825710

*dia. > 0.3 mm = 3.5 mm long

Thread Pin Gages 426 M in holders 426 A with an eyelet



426 M



426 A

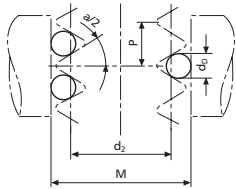

Features

426 M

- For determining pitch diameter of external threads according to the three-wire method
- In conjunction with micrometers, indicating measuring instruments or measuring machines
- Each pair consists of:
1 holder with 1 pin gage and
1 holder with 2 pin gages

finish, the retainer ring can be locked yet the measuring spindle can still rotate

- Pin gages are hardened and lapped. Freely floating in holder to allow proper positioning and contact with thread flanks

Manufacturing tolerance $\pm 0.5 \mu\text{m}$
 Mounting hole 7.5 mm
 (Mounting hole 6.35 mm = 1/4", 6.5 mm and 8 mm on request)

426 MS

Set of thread Pin Gages in
 Holder consists of:
 18 Holder Pairs 426 M

Diameter 0.17 - 3.2 mm
 Delivered in a wooden box

Order no.

Mounting hole 7.5 mm
 Mounting hole 6.5 mm

4820000
4820003

426 A

- For determining pitch diameter of external threads according to the three-wire method

- Designed to be suspended over a test specimen
- Set consists of 3 Pin Gages

Manufacturing tol. $\pm 0.5 \mu\text{m}$
 Pin gage length 32 mm

Technical Data

Pin Gage	Order no.			for thread pitch						
	426 M Pair dia. 7.5 mm	426 M Pair dia. 6.5 mm	426 A Set	Metric mm		Whitworth range tpi		American UST range tpi		Trapezoid mm
0.17	4820010	4820132	4821000	0.25	0.3					
0.195	4820011	4820149	4821001					80		
0.22	4820012	4820133	4821002		0.35			72		
0.25	4820013	4820131	4821003		0.4			64		
0.29	4820014	4820134	4821004	0.45	0.5			56		
0.335	4820015	4820135	4821005		0.6			48		
0.39	4820016	4820150	4821006			40		44	40	
0.455	4820017	4820137	4821007	0.7	0.75	0.8		32	36	
0.53	4820018	4820151	4821008					28	32	28
0.62	4820019	4820139	4821009		1		26	24	24	
0.725	4820020	4820140	4821010		1.25		22	20	20	
0.895	4820021	4820141	4821011		1.5		19	18	16	18
1.1	4820022	4820142	4821012		1.75		14	16	14	
1.35	4820023	4820143	4821013		2		12	11	12	11
1.65	4820024	4820144	4821014		2.5		10	9	10	9
2.05	4820025	4820145	4821015	3	3.5		8	7	8	7
2.55	4820026	4820146	4821016	4	4.5		6		6	6
3.2	4820027	4820147	4821017	5	5.5		5		5	4 1/2
4	*4820028	*4820152	4821018		6		4		4	3 1/2

* These holder pairs require the use of a 3 mm gage block for the holder with 2 pin gages to enlarge the measuring face. This gage block is inserted into the holder recess provided.

Setting Standards for indicating measuring instruments

AGD Masters



Master Rings

- Traceable certification and calibration available on request.
- Lapped to size and polished.
- Non-gaging areas black oxidized — ring faces ground.
- Meet all requirements of ANSI Specification B47.1-1988
- Manufactured in accordance with ANSI Specification B89.1.6-1984.

Master Discs AGD Style 3

- Traceable certification and calibration available on request.
- Lapped to size and polished.
- Non-gaging areas black oxidized — ring faces ground.
- Meet all requirements of ANSI Specification B47.1-1988
- Manufactured in accordance with ANSI Specification B89.1.5.
- Furnished with clear insulators.
- All dimensions are AGD style 3.

Master Plugs

- Traceable certification and calibration available on request.
- Stabilized and hardened.
- 100 % usable gaging surface.
- Ends ground square
- Lapped finish.

Setting Standards for indicating measuring instruments



355 E



390



715 E

Ring Gages 355 E

- Special wear-resistant gage steel. Hardened and lapped

Dimensions	DIN 2250, Type C
Manufacturing tolerance	DIN 2250
Uncertainty of actual deviation	1/2 IT 1
Nominal diameter	0.5 - 200 mm

Pin Gages 426

- Special wear-resistant gage steel. Hardened and lapped. Available with or without handles.
- According to DIN 2269

For further details please refer to Page 13-10
Nominal diameter 0.1 - 10 mm

Reference Discs 390

- Special wear-resistant gage steel. Hardened and lapped.

Manufacturing tolerance	± 1/2 IT 2
Uncertainty of actual deviation	1/2 IT 0
Nominal diameter over	10 - 100 mm

Setting standards with a DKD calibration certificate from the Mahr Calibration Laboratory are available on request (threads are excluded)

Pin Gages from dia.	3 mm
Ring Gages dia.	10 - 100 mm
Reference Discs dia.	3 - 100 mm

Thread Setting Ring Gage 708 E

- With full thread profile
- Actual deviation is engraved on the gage
- For setting indicating thread measuring instruments
- For metric threads for tolerance class "H" according to DIN 2241
- For other thread types please state tolerance requirements

Thread Setting Plug Gage 715 E

- With full thread profile
- Actual deviation is engraved on the gage
- For setting indicating thread measuring instruments
- Metric threads in accordance with DIN 2241:
Tolerance class h applies to standard threads dia. 1 - 1.4 mm and for pitches 0.2 and 0.25, for all other sizes the tolerance class g is applicable
- For other thread types please state tolerance requirements

Thread Gages, Checking Plug Gages



Thread Limit Plug Gage 705

- Special wear-resistant gage steel. Hardened and ground
- GO end with full thread profile, pitch diameter corresponds to minimum permissible dimension of internal thread
- NO-GO end has only 3 threads and a shortened flank profile, pitch diameter corresponds to maximum permissible dimension of internal thread
- Accuracy for metric ISO threads according to DIN ISO 1502 (up to 40 mm the GO end and NO-GO end are on a common handle. Over 40 mm the GO / NO-GO end are on separate handles for easier handling)
- Nominal diameter 1 - 100 mm. For all standard and special threads

Thread Ring Gages

- Special wear-resistant gage steel. Hardened and ground. Accuracy of metric ISO threads according to DIN ISO 1502
- Nominal diameter 1 - 200 mm
- For all standard and special threads

GO Thread Ring Gage 708 G

- With full thread profile. Pitch diameter corresponds to the maximum permissible dimension of an external thread. The external diameter is relieved

NO-GO Thread Ring Gage 708 N

- With reduced thread profile. For checking minimum permissible dimension of pitch diameter on external thread

Master Thread Plug Gages

- Special wear-resistant gage steel. Hardened and lapped. Accuracy for metric ISO thread DIN ISO 1502. Other threads are in accordance to the respective standards
- Diameter 1 - 200 mm
Available for all standard and special threads

Go Thread Checking Gage 715 G

Counter Plug Gage for GO Thread Ring Gage

Go Thread Checking Gage 715 N

Counter Plug Gage for NO-GO Thread Ring Gage

- With full thread profile and outside diameter with maximum dimension of external thread. Plug Gage must screw easily into Ring Gage

Wear Testing Plug Gage 716 G

For GO Thread Ring Gage

Wear Testing Plug Gage 716 N

For NO-GO Thread Ring Gage

- Three threads with considerably shortened flanks. Must not screw in more than one turn

Calibration Services

International Standards require complete documentation and calibration of all gaging instruments. Mahr Federal Inc., as well as being a manufacturer of quality dimensional measuring instruments, is an established primary source or high accuracy dimensional measurement services.

Mahr Federal offers an inspection and recalibration program for dimensional standards including:

- gage blocks / master rings / master discs and plugs / masterballs (roundness)
- cylindrical form and precision reference specimens surface roughness standards.



For these services, we have created an ideal environment - a metrology laboratory in Providence, Rhode Island that is ranked as one of the world's finest:

- High quality measurements - 0.06 micron / 2.3 microinch uncertainty of measurement on gage blocks (up to 50 mm / 2" long).
- All measurements traceable to the Standards of the United States.
- Grand Masters/Primary standards used in our Measurement Center have been certified by NIST.
- Calibration system is certified to ISO-9001:2000 by NQA, USA and accredited to ISO 17025 NVLAP Lab Code 200605-0.
- We offer Fast turnaround and competitive prices.



Mahr Federal also specializes in the calibration and certification of the following gages including:

- Dial, Digital & Test Indicators
- Mikrokators®
- Micrometers
- Dial & Vernier Calipers
- Pin & Radius Gages
- Snaps, I.D. / O.D. & Bore Gages
- Dimention® Plugs
- Plug & Ring Gages
- Groove, Caliper, Thickness
- Air Gages & Magnification Kits
- Electronic Amplifiers & Gage Heads
- Surface Finish Gages
- Level Systems



AMERICAS**USA****Mahr Federal Inc.**

Headquarters:
1144 Eddy Street,
Providence, RI 02905
.: +1-401-784-3100
+1-800-343-2050 (toll-free)
Fax: +1-401-784-3246
eMail: information@mahr.com

Cincinnati Resource Center:
11435 Williamson Road,
Cincinnati, OH 45241
Tel. +1-513-489-6116
Fax +1-513-489-6302
eMail: information@mahr.com

Los Angeles Resource Center:
11145 Knott Avenue, Suite G
Cypress, CA 90630
Tel. +1-714-379-7051
Fax: +1-714-379-0468
eMail: information@mahr.com

Mahr Metering Systems Corporation

1415 A Cross Beam Dr.
Charlotte, NC 28217
P.O. Box 7547
Charlotte, NC 28241
Tel.: +1-704-525-7128
+1-800-459-7867 (toll-free)
Fax: +1-704-525-8290
eMail: Info@MahrMeteringSystems.com

Mexico**Mahr Corp. de Mexico S.A. de C.V.**

Francisco Garza Sada #690,
Col. Chepevera
64030 Monterrey,
Nuevo León, México
Tel.: +52-81-8333-20-10
Fax: +52-81-8347-27-93
eMail: ventasmexiko@mahr.com

Brazil**Mahr do Brasil Ltda.**

Av. Washington Luis, 703
04662-001 São Paulo, SP
Brazil
Tel.: + 55-11-6687 5566
Fax: + 55-11-6687 5550
eMail: apoio.vendas@mahr.com.br

EUROPA**Germany****Mahr GmbH Göttingen**

Postfach 1853
37008 Göttingen
Carl-Mahr-Str. 1
37073 Göttingen
Tel.: +49-551-7073-800
Fax: +49-551-7073-888
eMail: info@mahr.de

Mahr GmbH Esslingen

Postfach 100254
73702 Esslingen
Reutlinger Straße 48
73728 Esslingen
Tel.: +49-711-9312-600
Fax: +49-711-9312-725
eMail: mahr.es@mahr.de

Mahr OKM GmbH

Carl-Zeiss-Promenade 10
07745 Jena
Tel. +49-3641 642696
Fax: +49-3641 643368
eMail: info-okm@mahr.de

**Mahr Kundenzentrum
Esslingen**

Reutlinger Straße 48
73728 Esslingen
Tel.: +49-711-9312-800
Fax: +49-711-9312-815
eMail: info-kuz-es@mahr.de

Mahr Kundenzentrum Wuppertal

Vorm Eichholz 2
42119 Wuppertal
Tel.: +49-202-710055
Fax: +49-202-710057
eMail: info-kuz-wu@mahr.de

Mahr Kundenzentrum Ingolstadt

Manchinger Straße 86
85053 Ingolstadt
Tel.: +49-841-965630
Fax: +49-841-9656311
eMail: info-kuz-in@mahr.de

Poland**Mahr GmbH****Przedstawicielstwo w Polsce**

Ul. Pulawska 5/4
02-515 Warszawa
Tel.: +48-7-92665446
eMail: arkadiusz.kolakowski@mahr.com

Российская Федерация**Представительство Mahr GmbH**

Проспект Вернадского 15
119311 Москва
Тел.: +7-495-138 5374
eMail: igor.lutsenko@mahr.com

**Czech Republic
Mahr spol. s.r.o.**

Ulice Kpt. Jaroše 552
41712 Proboštov
Czech Republic
Tel.: +420-417-816 711
Fax: +420-417-560 237
eMail: info-cz@mahr.com

Austria**Mahr Austria GmbH**

Hirschstettnerstraße 19-21
1220 Wien, Austria
Tel.: +43-1-204 36 73-0
Fax: +43-1-204 36 73-15
eMail: info-austria@mahr.com

France**Mahr France**

B.P. 27
6, rue Lavoisier-Z.I.
91430 Igny, France
Tel.: +33-1-69351919
Fax: +33-1-69351900
eMail: info@mahr.fr

Switzerland**Mahr AG Schweiz**

Zürcherstrasse 68
8800 Thalwil, Switzerland
Tel.: +41-44 723 39 99
Fax: +41-44 723 39 98
eMail: ch@mahr.com

United Kingdom / Ireland**Mahr U.K. Plc.**

19 Drakes Mews
Crownhill, Milton Keynes
MK 8 0ER, Great Britain
Tel.: +44-1908-563700
Fax: +44-1908-563704
eMail: info@mahruk.com

ASIA

China

Mahr China Ltd.

Hong Kong Office:
Unit G, 14F., CDW Building,
388 Castle Peak Road,
Tsuen Wan, N.T.
Hong Kong
Tel.: +852-2357 9683
Fax: +852-2763 9613
eMail: info@mahr.com.hk oder
sales@mahr.com.hk

Beijing Office:
Room 1502, Rong Xin Tower,
West Station, Fengtai District,
Beijing 100055, China
Tel.: +86-10-6332 4481/2/3
Fax: +86-10-6332 4492
eMail: info@mahr.com.hk oder
sales@mahr.com.hk

Shanghai Office:
1/F., No. 1146 Jia,
West Yan An Road, Changning District,
Shanghai 200052, China
Tel.: +86-21-5238 5353
Fax: +86-21-5238 6012
eMail: info@mahr.com.hk oder
sales@mahr.com.hk

Guangzhou Office:
Unit 1203, East Tower,
Guangzhou International Commercial
Center,
No. 122 Tiyudong Road,
Guangzhou 510620, China
Tel.: +86-20-3887 1132/1173
Fax: +86-20-3887 1172
eMail: info@mahr.com.hk oder
sales@mahr.com.hk

Mahr Precision Metrology (Suzhou) Ltd.

#399 Su Hong Road
Suzhou, Industrial Park
Suzhou 215021, P.R. China
Tel.: +86-512-62585862
Fax: +86-512-62585870
eMail: info_suzhou@mahr.com

Taiwan

Mahr China Ltd.

Taiwan Office:
No. 109, Sec. 1, Wunhua 1st Road,
Linkou Township, Taipei County 24447,
Taiwan R.O.C.
Tel.: +886-2-2600 6360
Fax: +886-2-2600 6362
eMail: info@mahr.com.hk oder
sales@mahr.com.hk

Korea

Mahr Korea Ltd.

Panwon B/D 6 F
38-30 Jangchung-dong 1-ga,
Chung-ku, Seoul 100-391
South Korea
Tel.: +82-2-579-4981
Fax: +82-2-579-4986/7
eMail: sales@mahr.co.kr

Japan

Mahr Japan Co., Ltd.

712-4-1, Mamedo-cho, Kohoku-ku,
Yokohama, 222-0032, Japan
Tel.: +81-45-540-3591
Fax: +81-45-540-6252
eMail: info@mahr.co.jp

Osaka Branch
2-3-5, Andoji-cho, Chuo-ku,
Osaka-shi, 542-0061, Japan
Tel.: +81-6-6763-5191
Fax: +81-6-6763-5192

Malaysia

Mahr Malaysia Sdn. Bhd.

No. 130, Block B 1,
Leisure Commerce Square
No. 9, Jalan PJS 8/9,
46150 Petaling Jaya, Selangor Darul Ehsan
Malaysia
Tel.: +60-3-78772060
Fax: +60-3-78772040
eMail: sales@mahr.com.my

Thailand

Mahr S.E.A. Co. Ltd.

719 KPN Tower, 20th Floor
Rama 9 Rd., Bangkapi, Huaykwang
Bangkok 10310, Thailand
Tel.: +66-2-717 1050-4
Fax: +66-2-717 1055
eMail: info@mahr.co.th

India

Mahr Metrology India Pvt. Ltd.

Corporate Office
R-38, 6th Main Road
Anna Nagar
Chennai-600 040, Indien
Tel.: +91-44-42170531
Fax: +91-44-42170531
eMail: mahrindia@mahr.com

Please refer to our website www.mahr.com
for addresses of our worldwide Sales
Partners (not included in the Mahr Group)

© by Mahr GmbH, Esslingen / Göttingen

We reserve the right to make changes to
our products, especially due to technical
improvements and further developments.

All illustrations and technical data are
therefore without guarantee.

WWW.MAHR.COM

|
- 0 +

Mahr

E X A C T L Y

Mahr Federal Inc. • 1144 Eddy Street • Providence • RI 02905 • Phone +1-800-343-2050 • Fax: +1-401-784-3246
Email: information@mahr.com

Mahr GmbH Esslingen

Reutlinger Straße 48, 73728 Esslingen
Tel. +49 711 9312 600, Fax +49 711 9312 725
mahr.es@mahr.de, www.mahr.com